

Azbil TA - Fluid Control Technology at Its Best

General Catalogue

- Pneumatic Equipment
- Centralized Lubrication System
- Pneumatic Sensing System
- System Engineering



TACO CO., LTD. changed its name to
Azbil TA Co., Ltd. on April 1, 2013.

INDEX

SOLENOID VALVES, DUAL VALVES, SILENCERS	1~52
MASTER VALVES, PILOT VALVES, HAND VALVES	53~82
AUXILIARY CIRCUIT COMPONENTS	83~94
PRESSURE SWITCHES, AIR LIMITERS	95~106
AIR FILTERS	107~110
AIR REGULATORS, HIGH-SET, PRESSURE GAUGES	111~139
LUBRICATORS, CHARGE TANKS, SPRAY SYSTEMS	140~145
AIR LINE CENTRALIZED LUBRICATION UNITS	146~151
CPL MICRON-LUB LUBRICATION UNITS SEMI-DRY LUBRICATION UNITS HYBRID LUBRICATION UNITS	152~165

INDEX

SOLENOID VALVES, DUAL VALVES

5-PORT SPOOL OPERATED SOLENOID VALVE

501 SERIES	1~ 5
MVS(D)-495Y SERIES	6~ 9
MVS(D)-492Y SERIES 1/4B BASE	10~ 13
524 SERIES	14~ 17
MVS(D)-492 SERIES 1B BASE	18~ 20
MVS(D)-4900 SERIES	21~ 24

4-PORT POPPET OPERATED SOLENOID VALVE

460 SUPER POPPET SERIES (2-POSITION, 3-POSITION)	25~ 30
--	--------

3-PORT POPPET OPERATED SOLENOID VALVE

360 SUPER POPPET SERIES	31~ 33
360 SUPER POPPET SERIES (VACUUM)	34~ 35
360 SUPER POPPET SERIES (HIGH-LOW PRESSURE CHANGE)	36~ 38
392 SERIES	39~ 40
354 SERIES, MVS-3500YCG/YCL/YCK SERIES (PRESS PURPOSE)	41~ 44

2-PORT SOLENOID VALVE

MVS-2200Y, MVS-2300Y SERIES	45~ 46
260 SUPER POPPET SERIES	47~ 49
260 SUPER POPPET SERIES (VACUUM)	50~ 51

SILENCER

MFF-200, 300 SERIES	52
---------------------------	----

MASTER VALVE

5-PORT SPOOL OPERATED MASTER VALVE

MVM-495 SERIES	53~ 54
MVM-492 SERIES 1/4B BASE	55~ 56
524-M SERIES 1/2B BASE	57~ 58
MVM-491 SERIES 1B BASE	59~ 60
MVM-491 SERIES 1-1/2B BASE	61~ 62

4-PORT POPPET OPERATED MASTER VALVE

460 SUPER POPPET SERIES (2-POSITION, 3-POSITION)	63~ 67
--	--------

3-PORT POPPET OPERATED MASTER VALVE

360 SUPER POPPET SERIES	68~ 69
360 SUPER POPPET SERIES (HIGH-LOW PRESSURE CHANGE)	70~ 71
392 SEIRES (COMPRESSED AIR AND VACUUM)	72

2-PORT POPPET OPERATED MASTER VALVE

260 SUPER POPPET SERIES	73~ 74
-------------------------------	--------

PILOT VALVE

5-PORT PILOT VALVE

POV-4000, 3000 SERIES	75~ 80
-----------------------------	--------

HAND VALVE

DV-4100 SERIES	81~ 82
----------------------	--------

AUXILIARY CIRCUIT COMPONENTS

SPEED CONTROLLER

SC-100, 200, 300, 700, 800Y SERIES	83~ 84
--	--------

QUICK EXHAUST VALVE

G01, QEV-3300 (Y) SERIES	85
--------------------------------	----

CHECK VALVE

CV-100, 200 SERIES	86
--------------------------	----

SHUTTLE VALVE

J01, CV-3100 (Y) SERIES	87
-------------------------------	----

RELIEF VALVE

V31 SERIES	88
NSV-200 SERIES	89
NSV-500 SERIES	90
NSV-300 SERIES	91

CUSHION VALVE

CUV-400 SERIES	92
----------------------	----

EJECTOR UNIT FOR VACUUM GENERATOR

VC1 SERIES	93~94
------------------	-------

PRESSURE SWITCH

PSD-101 SERIES	95~ 96
P02-200 SERIES	97

AIR LIMITER

S51 SERIES	98~102
AOL-112 SERIES	103~105

EXCLUSIVE PURGE VALVE FOR AIR LIMITER

MVS-214-02S-07	106
----------------------	-----

AIR FILTER

NAF-500 SERIES	107~108
NAF-600 SERIES	109

SELF-DRAIN UNIT

SDU-200, 300XL SERIES	110
-----------------------------	-----

AIR REGULATOR

R31 SERIES	111
RK-1206 SERIES	112~113
NRV-300, 200 SERIES	114~115
NRV-400 SERIES	116~117
RVD-400YF SERIES	118
NRV-500 SERIES	119~120
RVD-500YF SERIES	121
R50 SERIES	122~123
R50-R SERIES	124~125
R50-M SERIES	126~127
NRV-802 SEIRES	128
NRV-802D SERIES	129
NRV-502JD SERIES	129
R42 SERIES	130
NRV-300A SERIES	131
R31, RL4, NRV-1200 SERIES (WATER PURPOSE)	132~133

HIGH SET

HS-400Y2 SERIES	134
HSP-302 SERIES (PILOT REGULATOR FOR HS-400Y2 SERIES)	135
H30/H50 SERIES	136~138

PRESSURE GAUGE

GAB, GBB SERIES	139
-----------------------	-----

LUBRICATOR

NOL-500 SERIES	140~141
NOL-800 SERIES	142

CHARGE TANK

OT-※002YXL SERIES	143
-------------------------	-----

SPRAY SYSTEM

SLC SERIES	144~145
------------------	---------

TOTAL-LUB

ADVANTAGES OF TOTAL-LUB	146
TLC, TLB SERIES	147~148
TLD SERIES, TCU CONTROL BOX	149
C08-0116 SERIES	150
TA4 SERIES	151

CPL MICRON-LUB LUBRICATION UNIT

MCD SERIES	152~153
MC9 SERIES	154~155
MC5 SERIES	156~157

SEMI-DRY LUBRICATION UNIT

L32 SERIES	158~159
MQ4 SERIES	160~161
MCA SERIES	162~163

HYBRID LUBRICATION UNIT

MCB SERIES	164~165
------------------	---------

BASED ON CYLINDER SIZE AND SPEED

VALVE SIZE SELECTION CHART

THIS CHART SHOWS TO FIND THE SUITABLE EFFECTIVE AREA OF THE VALVE FROM THE PLANNING CYLINDER SIZE AND ITS SPEED.

CYLINDER SPEED
(mm/sec)

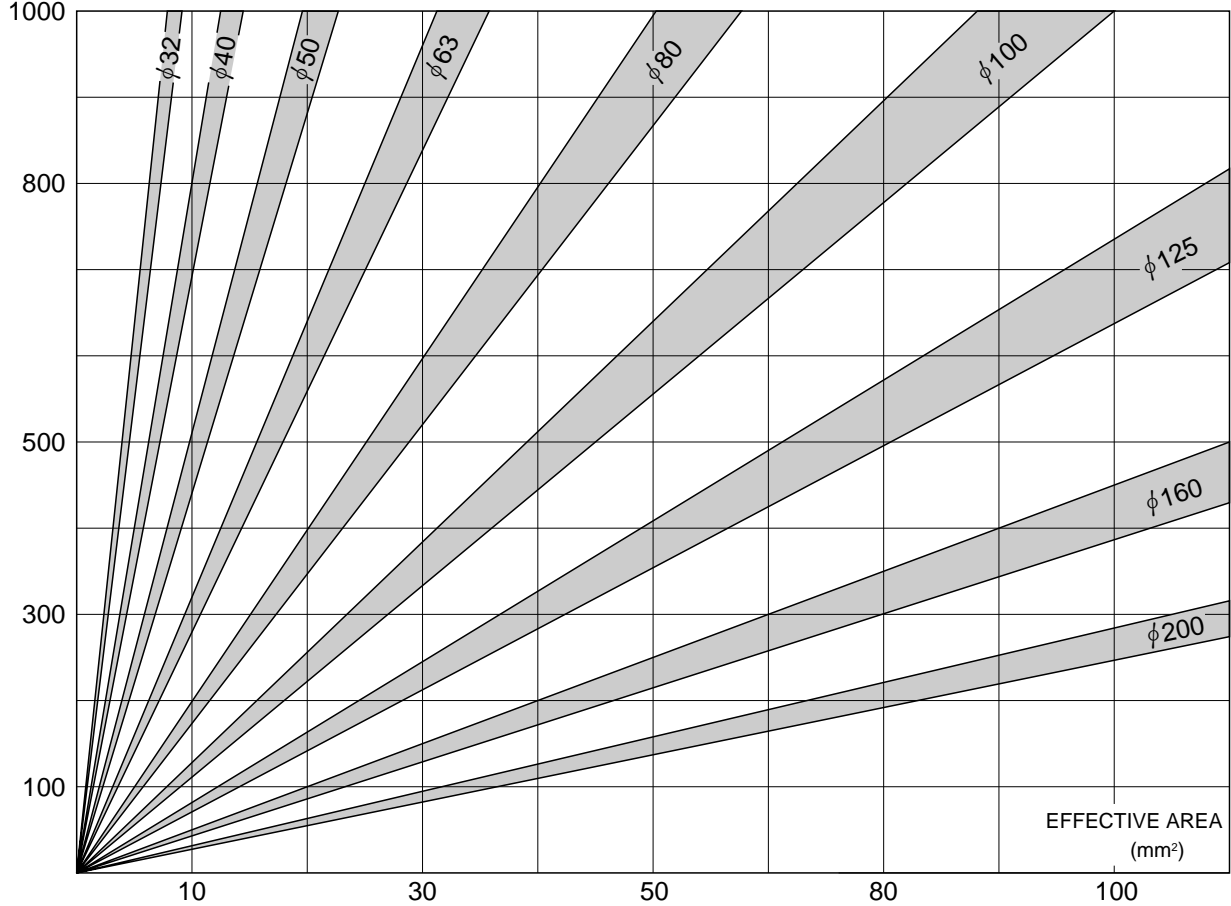

CYLINDER SPEED
(mm/sec)

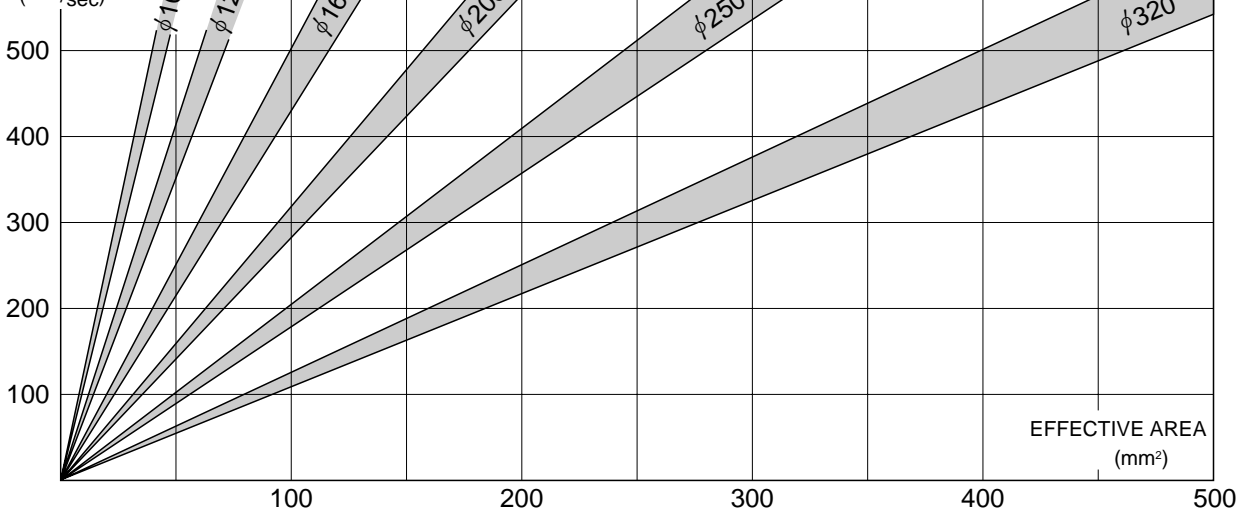

NOTE: THE CYLINDER SPEED SHOWN ON THE ABOVE CHART IS CALCULATED FROM THE EFFECTIVE AREA OF THE VALVE ONLY WITH 0.50~0.65 CYLINDERS' LOADING RATIO. OTHER FACTORS SUCH AS SPEED CONTROL VALVES, PIPINGS AND ITS FITTINGS ARE NOT CONSIDERED ON THIS CASE.

CONVERSION TABLE FOR UNITS USED IN THIS CATALOG.

● **PRESSURE**

1kgf/cm²≒0.0980MPa
≒0.1MPa

● **FORCE**

1kgf=9.80665N
≒10N

● **AIR FLOW**

1Nℓ/min=1ℓ/min (ATMOSPHERIC CONDITION)
=1dm³/min (ANR)

● **TORQUE**

1kgf·cm≒0.1N·m
≒0.87ℓbf·in
≒0.0725ℓbf·ft

■ **PRESSURE**

Pa or N/m ²	MPa or N/mm ²	bar	kgf/cm ²	lbf/in ²	atm	mHg	mAg
1	1×10 ⁻⁶	1×10 ⁻⁵	1.020×10 ⁻⁵	1.450×10 ⁻⁴	9.869×10 ⁻⁶	7.501×10 ⁻⁶	1.020×10 ⁻⁴
1×10 ⁶	1	1×10	1.020×10	1.450×10 ²	9.869	7.501	1.020×10 ²
1×10 ⁵	1×10 ⁻¹	1	1.020	1.450×10	9.869×10 ⁻¹	7.501×10 ⁻¹	1.020×10
9.807×10 ⁴	9.807×10 ⁻²	9.807×10 ⁻¹	1	1.422×10	9.678×10 ⁻¹	7.356×10 ⁻¹	1×10
6.895×10 ³	6.895×10 ⁻³	6.895×10 ⁻²	7.031×10 ⁻²	1	6.805×10 ⁻²	5.171×10 ⁻²	7.031×10 ⁻¹
1.013×10 ⁵	1.013×10 ⁻¹	1.013	1.033	1.470×10	1	7.600×10 ⁻¹	1.033×10
1.333×10 ⁵	1.333×10 ⁻¹	1.333	1.360	1.934×10	1.316	1	1.360×10
9.807×10 ³	9.807×10 ⁻³	9.807×10 ⁻²	1×10 ⁻¹	1.422	9.678×10 ⁻²	7.355×10 ⁻²	1

◇ **CONVERSION TABLE BETWEEN JIS PIPE SIZE (R, Rc) AND AMERICAN PIPE SIZE (NPT)**

NOMINAL SIZE	NOs. OF THREAD/25.4mm		EFFECTIVE DIA. (D2 OR E1) (mm)		PITCH OF THREAD (mm)		DIFFERENCE OF PITCH (mm)	OUTER DIA OF PIPE(REF.) (mm)	
	R·Rc	NPT	R·Rc	NPT	R·Rc	NPT		JIS	NPT
1/16	28	27	7.142	7.142	0.9071	0.9408	0.0337	—	7.94
1/8	28	27	9.147	9.489	0.9071	0.9408	0.0337	10.5	10.29
1/4	19	18	12.301	12.487	1.3368	1.4112	0.0744	13.8	13.72
3/8	19	18	15.806	15.926	1.3368	1.4112	0.0744	17.3	17.15
1/2	14	14	19.793	19.772	1.8143	1.8143	0	21.7	21.34
3/4	14	14	25.279	25.117	1.8143	1.8143	0	27.2	26.67
1	11	11.5	31.770	31.461	2.3091	2.2088	0.1003	34.0	33.40
1¼	11	11.5	40.431	40.218	2.3091	2.2088	0.1003	42.7	42.16
1½	11	11.5	46.324	46.287	2.3091	2.2088	0.1003	48.6	48.26
2	11	11.5	58.135	58.325	2.3091	2.2088	0.1003	60.5	60.33
2½	11	8	73.705	70.159	2.3091	3.1750	0.8659	76.3	73.03
3	11	8	86.405	86.068	2.3091	3.1750	0.8659	89.1	88.90

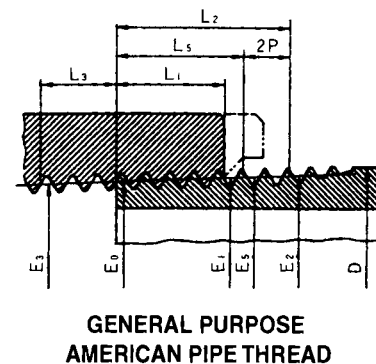
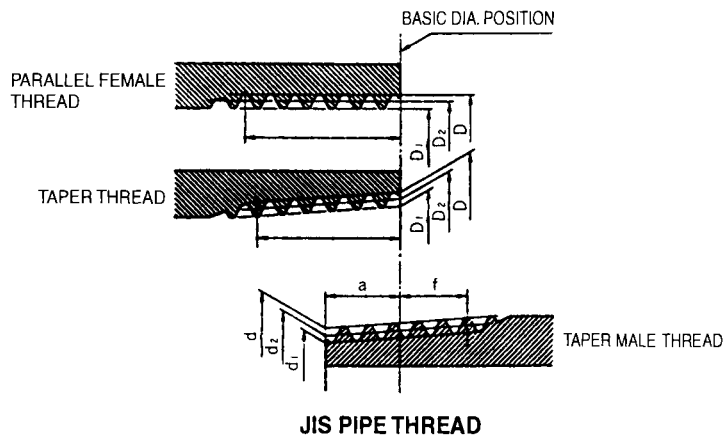

5 PORT SOLENOID VALVE

501 SERIES (Rc¹/₄)

IN-LINE TYPE

SPECIFICATIONS

FLUID	Filtered Compressed Air
OPERATING PRESSURE	0.15 ~ 0.9MPa
AMBIENT TEMPERATURE	5 ~ 50°C
LUBRICANTS	ISO VG32 turbine oil, or equivalent oil is recommended.
MANUAL OPERATION	Manual push button/Non-lock type
RATED VOLTAGE	<ul style="list-style-type: none"> • AC-100V 50/60Hz, 110V 60Hz • AC-200V 50/60Hz, 220V 60Hz • DC-24V • DC-100V
VOLTAGE ALLOWANCE	-15 ~ 10%
INSULATION GRADE	Class B

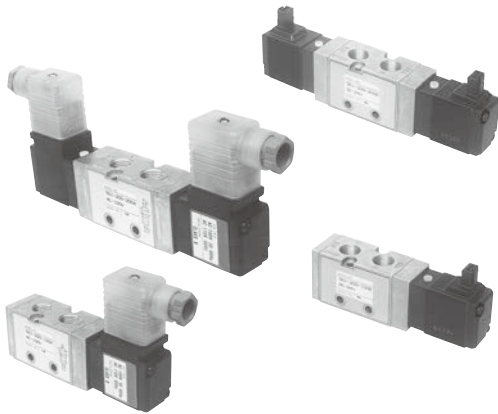

BASIC MODEL NOS. & OTHERS

Pipe Size	Function		MODEL NUMBER		Effective Area [mm ²] < Cv value >		Mass [kg]
	Position	Solenoid & Function	Free Lead	DIN type Connector w/pilot lamp & surge killer	IN-OUT	OUT-IN	
Rc ¹ / ₄	2 position	Single Solenoid	501-200-1006	501-200-1004	21	18	0.18
		Double Solenoid	501-200-2006	501-200-2004	< 1.1 >	< 0.97 >	
	3 position	Closed Center	501-200-3006	501-200-3004	< 18 > < 0.97 >	< 13 > < 0.70 >	0.37
		Exhaust Center	501-200-4006	501-200-4004			
		Pressure Center	501-200-5006	501-200-5004			

HOW TO ORDER

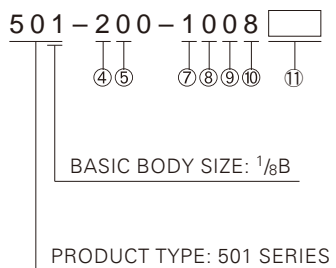

④ Pipe Size

2	"1" "2" "4" port Rc ¹ / ₄ "3" "5" port Rc ¹ / ₈
---	--

⑤ Mounting

0	Inline
---	--------

⑦ Solenoid & Function

1	2 position Single Solenoid
2	2 position Double Solenoid
3	3 position Closed Center
4	3 position Exhaust Center
5	3 position Pressure Center

⑧ Pilot Air Supply

0	Internal pilot
---	----------------

⑨ Accessory

0	Manual push button/Non-lock type
1	Manual handle/Lock type

⑩ Electric Connection

4	DIN type Connector (with pilot lamp and surge killer)
6	Free Lead Wire

⑪ Rated Voltage

AC-100V	AC-100V 50/60Hz, 110V 60Hz
AC-200V	AC-200V 50/60Hz, 220V 60Hz
DC-24V	DC-24V

501-200-10*6

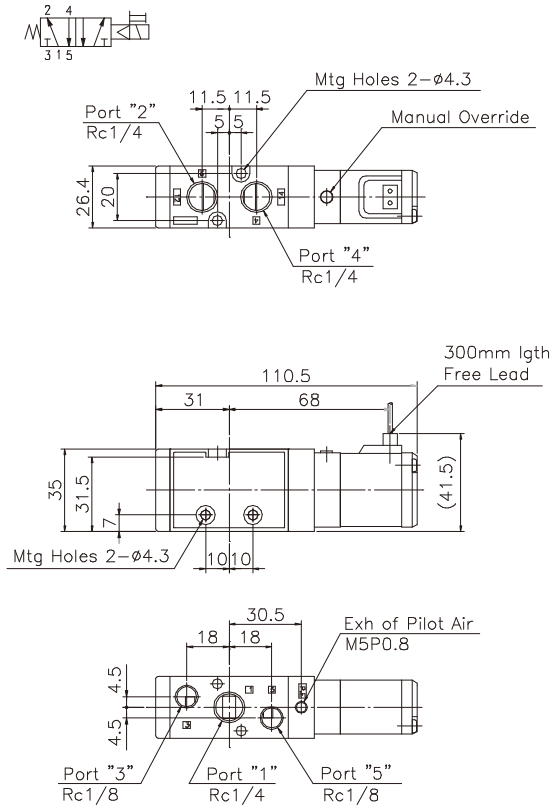

NOTE:

1. Magnet coil contains 300mm length lead wire.
2. Location of a manual override, and lead wire site are possible to rotate 180° onto the standard assembly.

501-200-20*6

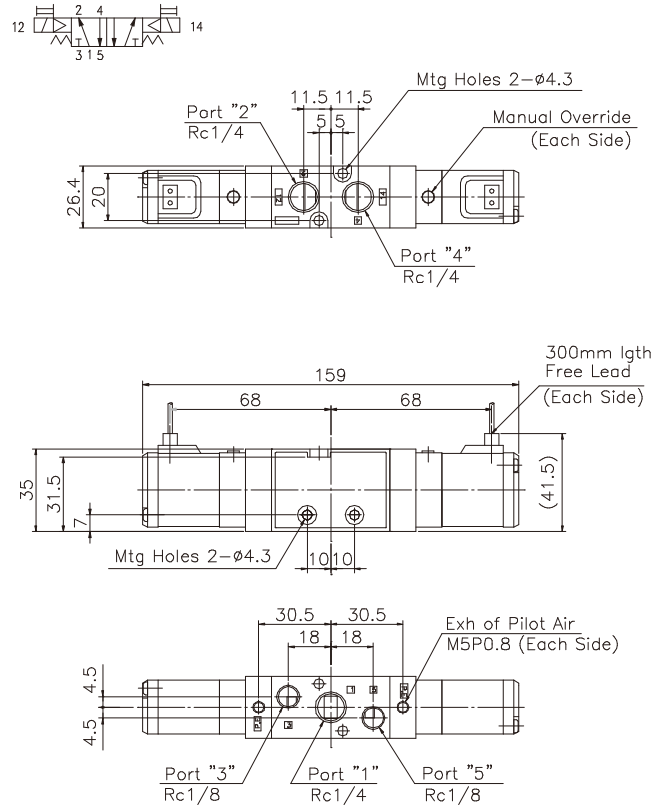

NOTE:

1. Magnet coil contains 300mm length lead wire.
2. Location of a manual override, and lead wire site are possible to rotate 180° onto the standard assembly.

501-200-30*6

501-200-40*6

501-200-50*6

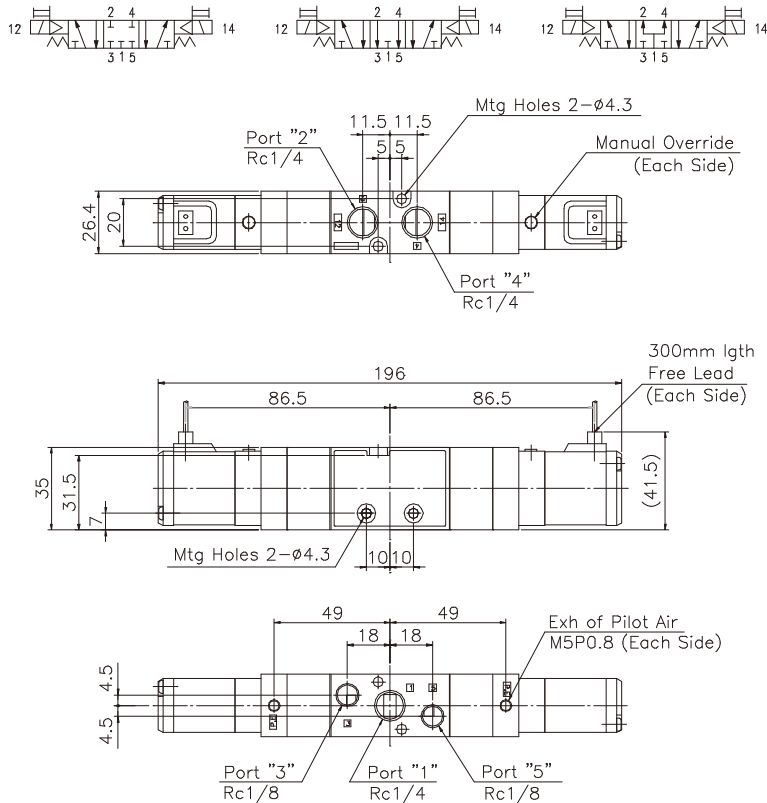

NOTE:

1. Magnet coil contains 300mm length lead wire.
2. Location of a manual override, and lead wire site are possible to rotate 180° onto the standard assembly.

501-200-10*4

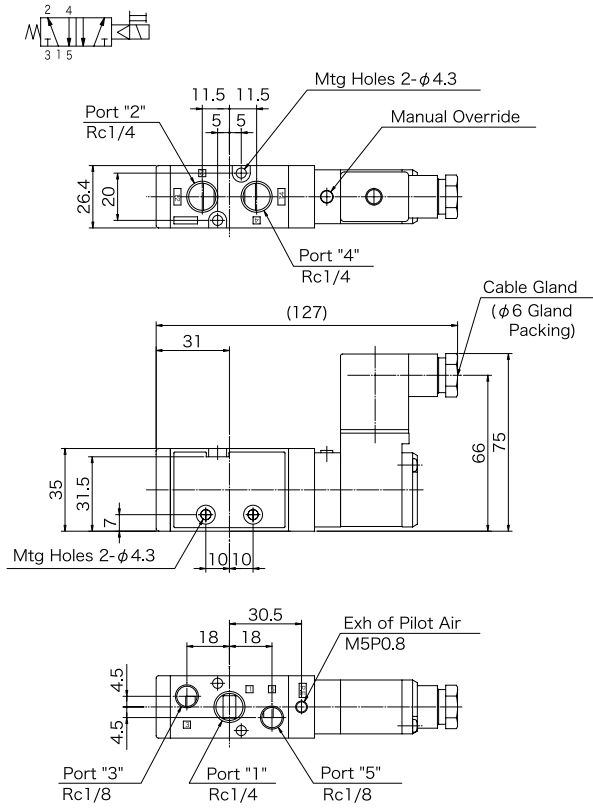

501-200-20*4

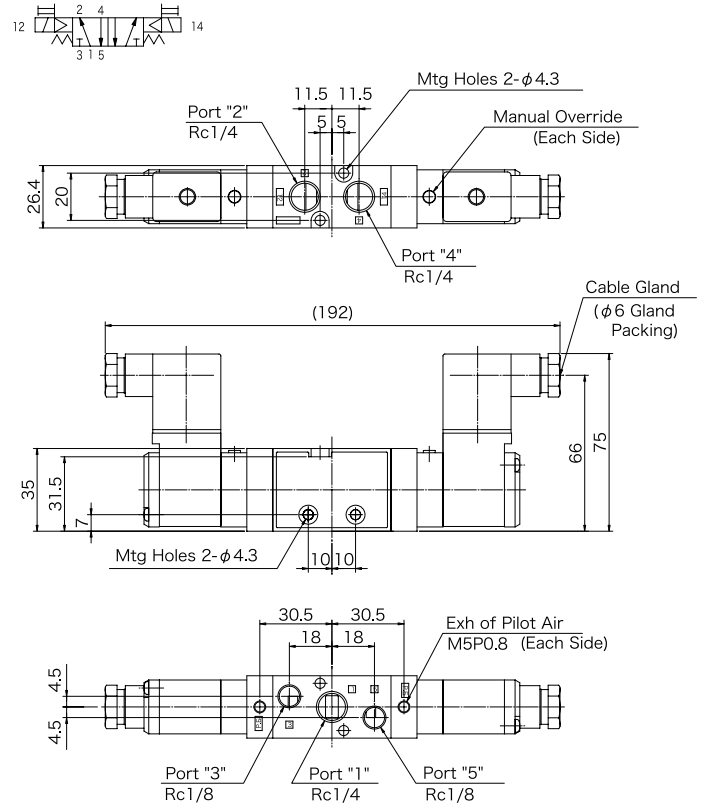

501-200-30*4

501-200-40*4

501-200-50*4

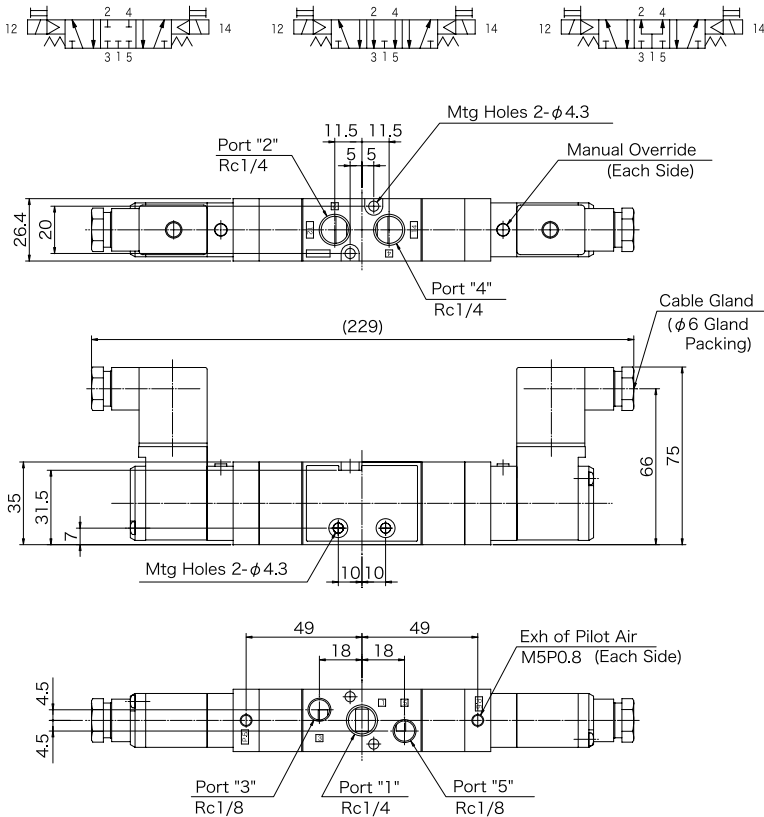

Handling of DIN Connector

Electrical Wiring

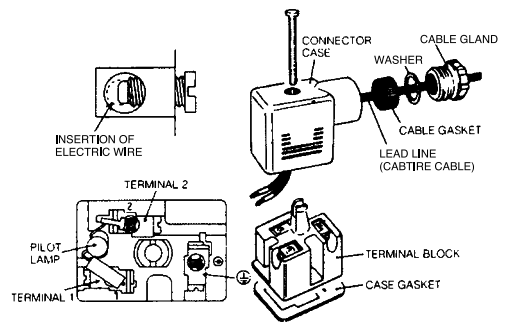

Specifications of DIN Connector

Includes Pilot Lamp and Surge Killer	
Rated Voltage	AC100V, AC200V, DC24V
Applicable Cable	OD φ6~8mm Cabtyre Cord Conductor: 0.5~1.5mm ²
Pilot Lamp	Neon Lamp for AC100/200V, LED for DC24V

DIN Connector Service Kit

90215-11	For AC 100V
90215-12	For AC 200V
90215-33	For DC 24V

5 PORT SOLENOID VALVE

501 SERIES

TOUCH MANIFOLD TYPE

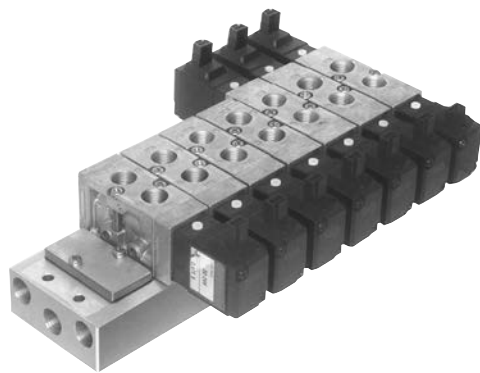

SPECIFICATIONS

Pipe Size	"1" "3" "5" port (common port)	Rc ¹ / ₄ (on sides of manifold block)
	"2" "4" port (separate port)	Rc ¹ / ₄ (on each valve body)
Effective Area (IN-OUT/OUT-EX)		21/18mm ² 2 position Single/Double solenoid
		18/13mm ² 3 position Double solenoid
Max. no. of valves possible on the manifold block		8

* Other specifications are common to 501 Series, In-line type.

HOW TO ORDER

501-2T0 × -

① ② ③ ④

PRODUCT TYPE:
TOUCH-MANIFOLD 501 SERIES

Note: Valves mounted on the same manifold block should have the same accessories.

① Nos. of valve fitted on manifold block

2, 4, 6, 8 available

*Manifold blocks are available only even number valve mounts. Use a cover plate at extra mount when the number of valves on manifold block is odd number.

② Accessory

NIL	<ul style="list-style-type: none"> Manual push button/Non-lock type Free lead connection
L	<ul style="list-style-type: none"> Manual handle/Lock type (screw-in type) Free lead connection
S	<ul style="list-style-type: none"> Manual button/Non-lock type DIN type connector (with pilot lamp and surge killer)
D	<ul style="list-style-type: none"> Manual handle/Lock type (screw-in type) DIN type connector (with pilot lamp and surge killer)

③ Specifying of Solenoid Valve to be mounted

Specify valves and accessories by letters in the following table. The valve mounting arrangement writes down the letters in order from left side with viewing of following direction.

Return spring side of single solenoid valve and/or "12" solenoid side of double solenoid valve is placed towards your body side with the manifold block underneath.

[EXAMPLE FOR ABOVE PHOTO] 501-2T0×6-222111Y

Letter	"2" "4" port	MODEL NUMBER	Accessory	Function
1	Rc ¹ / ₄	501-2T0-1006	NIL	Single Solenoid
		-1016	L	
		-1004	S	
		-1014	D	
2		501-2T0-2006	NIL	Double Solenoid
		-2016	L	
		-2004	S	
		-2014	D	
3		501-2T0-3006	NIL	3 position Closed Center
		-3016	L	
		-3004	S	
		-3014	D	
4	501-2T0-4006	NIL	3 position Exhaust Center	
	-4016	L		
	-4004	S		
	-4014	D		
5	501-2T0-5006	NIL	3 position Pressure Center	
	-5016	L		
	-5004	S		
	-5014	D		
Y		Plate for covering		Covering of non use valve mount

④ Rated Voltage

AC-100V	AC-100V 50/60Hz, 110V 60Hz
AC-200V	AC-200V 50/60Hz, 220V 60Hz
DC-24V	DC-24V

5 PORT SOLENOID VALVE

495Y SERIES (Rc^{1/4}, Rc^{3/8})

IN-LINE TYPE

Pilot operated spool valve



SINGLE SOLENOID



DOUBLE SOLENOID

SPECIFICATIONS

FLUID	Filtered Compressed Air
OPERATING PRESSURE	0.2 ~ 0.95MPa (Internal Pilot Supply type)
	0 ~ 0.95MPa (External Pilot Supply type)
AMBIENT TEMPERATURE	5 ~ 50°C
LUBRICANTS	ISO VG 32 turbine oil, or equivalent oil is recommended.
MANUAL OPERATION	Manual push button/Non-lock type
RATED VOLTAGE	<ul style="list-style-type: none"> • AC-100V 50/60Hz, 110V 60Hz • AC-200V 50/60Hz, 220V 60Hz • DC-24V • DC-100V
VOLTAGE ALLOWANCE	-15 ~ 10%
INSULATION GRADE	Class B

BASIC MODEL NOS. & OTHERS

Pipe Size	Function		MODEL NUMBER	Effective Area [mm ²] < Cv value >	Mass [kg]
	Position	Solenoid & Function	DIN type Connector		
Rc ^{1/4}	2 position	Single Solenoid	MVS-495-02Y	35 < 1.9 >	0.6
Rc ^{3/8}			MVS-495-03JY		
Rc ^{1/4}		Double Solenoid	MVD-495-02Y		0.8
Rc ^{3/8}			MVD-495-03JY		
Rc ^{1/4}	3 position	Closed Center	MVD-435-02Y		1.0
Rc ^{3/8}			MVD-435-03JY		
Rc ^{1/4}		Exhaust Center	MVD-445-02Y		
Rc ^{3/8}			MVD-445-03JY		
Rc ^{1/4}		Pressure Center	MVD-455-02Y		
Rc ^{3/8}			MVD-455-03JY		

HOW TO ORDER

MV - 4 5 - Y

PRODUCT TYPE: 495Y SERIES

① Nos. of Solenoid

S Single Solenoid
D Double Solenoid

② Positions & Function

9 2 position Single/Double
3 3 position Closed Center
4 3 position Exhaust Center
5 3 position Pressure Center

③ Pipe Size

02 Rc^{1/4}
03J Rc^{3/8} (over ported)

④ Solenoid Electricity

NIL For AC use (Std.)
H For DC use

⑤ Use

NIL Standard

⑥ Pilot Air Supply

NIL Internal pilot air supply
P External pilot air supply

⑦ Accessory

NIL Manual push button/Non-lock type
R Lock type manual operation button
S DIN connector with pilot lamp

⑧ Rated Voltage

AC-100V	AC-100V 50/60Hz, 110V 60Hz
AC-200V	AC-200V 50/60Hz, 220V 60Hz
DC-24V	DC-24V
DC-100V	DC-100V

MVS-495-02Y, 03JY

H-7450

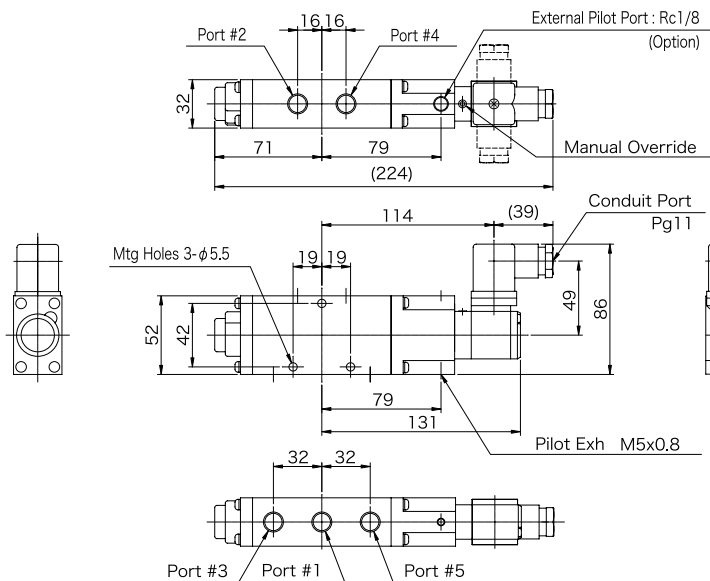
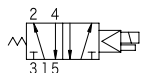

Pg11 is applicable to cable of ϕ 6~14mm OD.

MVD-495-02Y, 03JY

H-7451

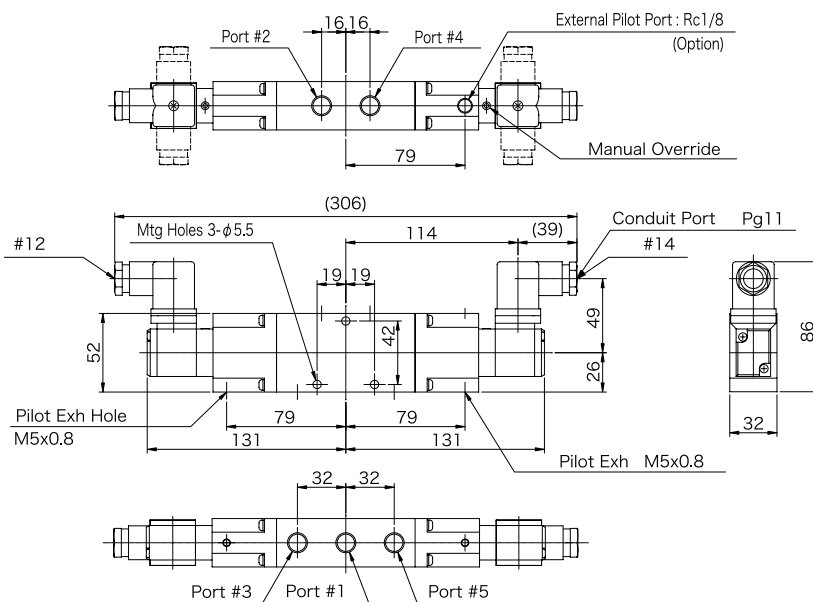
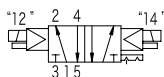

Pg11 is applicable to cable of ϕ 6~14mm OD.

MVD-495-02Y, 03JY

H-7452

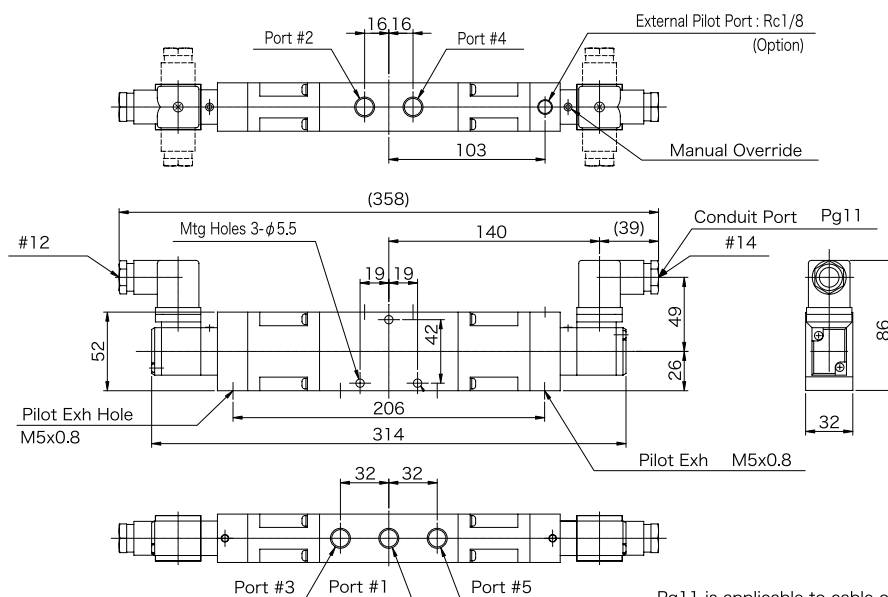
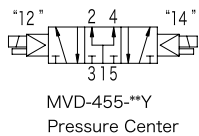
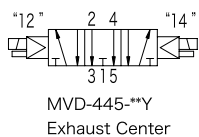
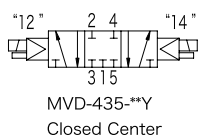

Pg11 is applicable to cable of ϕ 6~14mm OD.

5 PORT SOLENOID VALVE

495Y SERIES

STACK-MANIFOLD TYPE

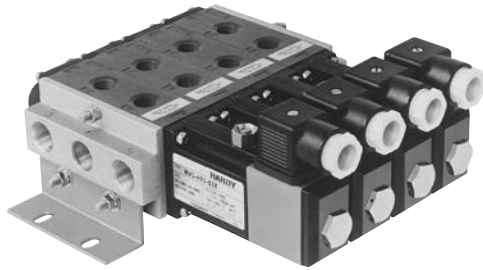

SPECIFICATIONS

Pipe Size	"1" "3" "5" port (common port)	Rc ³ / ₈ (on both end plates)
	"2" "4" port (separate port)	Rc ¹ / ₄ or Rc ³ / ₈ (on each valve body)
Effective Area	35mm ²	
Maximum number of valves available for forming stack manifold	8	

* Other specifications are common to 495Y Series, In-line type.

HOW TO ORDER

MVK-503Y × -

① ② ③ ④ ⑤ ⑥

Common port pipe size
"1" "3" "5" port: Rc³/₈

PRODUCT TYPE:
STACK-MANIFOLD 495Y SERIES

Note: Valves assembled in the same stack manifold should have the same accessories.

① Nos. of valve mounts on manifold

2 ~ 8 available

② Solenoid Electricity

NIL | AC use (Std.)
H | DC use

③ Pilot Air Supply

NIL | Internal pilot air supply
P | External pilot air supply

④ Accessory

NIL | Manual push button/Non-lock type
R | Manual push button/Lock type (screw-in type)
S | DIN type connector with pilot lamp

⑤ Specifying of Solenoid Valve to be mounted

Specify valves and accessories by letters in the following table. The valves mounting arrangement write down the letters in order from left side with viewing of following direction.

Return spring side of single solenoid valve and/or "12" solenoid side of double solenoid valve is placed towards this side with "2", "4" port side upwards.

Letter	"2" "4" port	MODEL NUMBER	Function
1	Rc ¹ / ₄	MVS-495-02KY	Single Solenoid
6	Rc ³ / ₈	MVS-495-03JKY	
2	Rc ¹ / ₄	MVD-495-02KY	Double Solenoid
7	Rc ³ / ₈	MVD-495-03JKY	
3	Rc ¹ / ₄	MVD-435-02KY	3 position Closed Center
8	Rc ³ / ₈	MVD-435-03JKY	
4	Rc ¹ / ₄	MVD-445-02KY	3 position Exhaust Center
9	Rc ³ / ₈	MVD-445-03JKY	
5	Rc ¹ / ₄	MVD-455-02KY	3 position Pressure Center
0	Rc ³ / ₈	MVD-455-03JKY	
P	—	IN port block	Block for additional IN port
Y	—	Separator	Plate for separating IN of manifold

⑥ Rated Voltage

AC-100V	AC-100V 50/60Hz, 110V 60Hz
AC-200	AC-200V 50/60Hz, 220V 60Hz
DC-24V	DC-24V
DC-100V	DC-100V

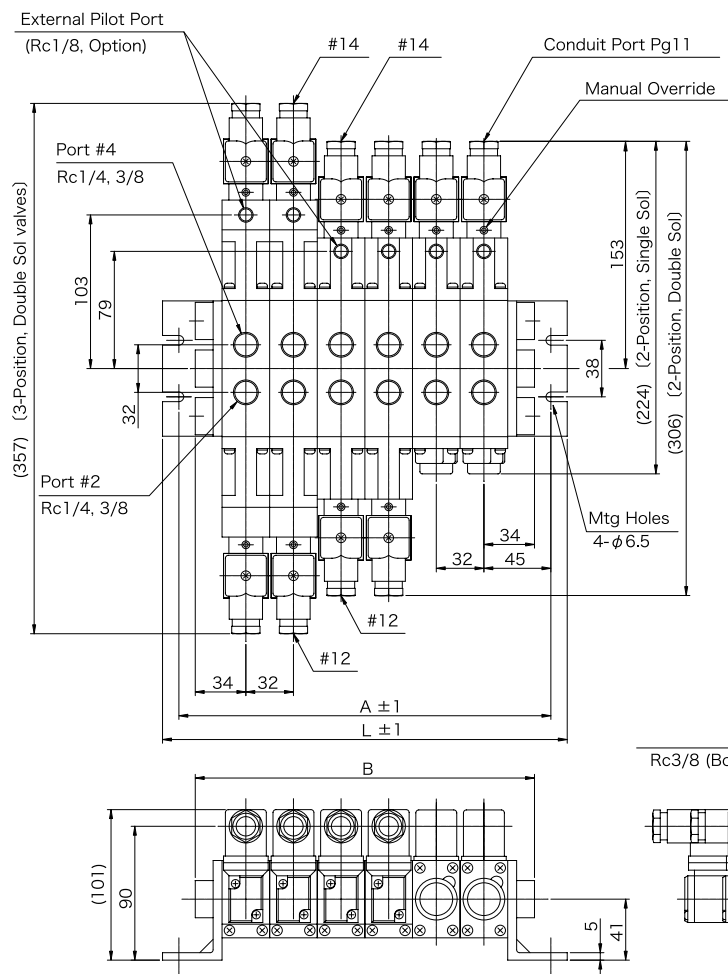

<Symbols of Valve Function>

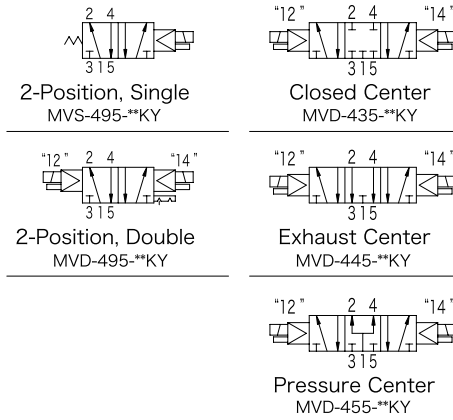

<Dimensions>

N	2	3	4	5	6	7	8
A	122	154	186	218	250	282	314
B	100	132	164	196	228	260	292
L	144	176	208	240	272	304	336

N: Numbers of valve units stacked.
 A: Pitch of Mounting Holes
 L: Total Length of Stacked Manifold

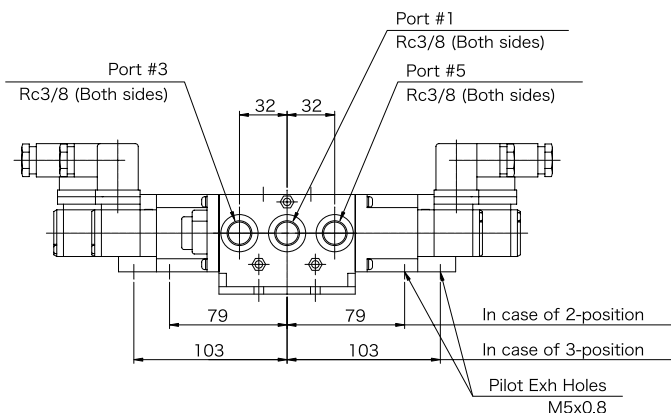

(Note)
 Pg11 conduit ports are applicable to cable of outer dia : φ6~10mm.

5 PORT SOLENOID VALVE

492Y SERIES (Rc^{1/4}, Rc^{3/8})

SUB-BASE TYPE

Pilot operated spool valve

SPECIFICATIONS

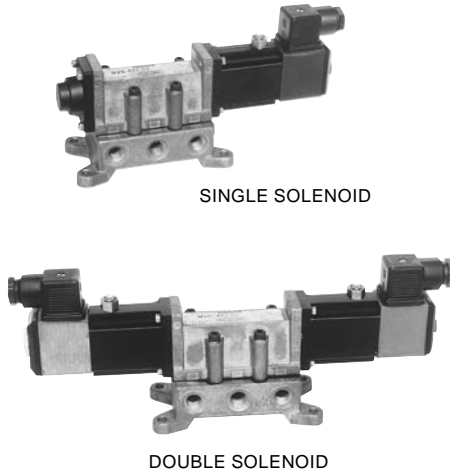

FLUID	Filtered Compressed Air
OPERATING PRESSURE	0.2 ~ 0.95MPa (Internal Pilot Supply type)
	0 ~ 0.95MPa (External Pilot Supply type)
AMBIENT TEMPERATURE	5 ~ 50°C
LUBRICANTS	ISO VG32 turbine oil, or equivalent oil is recommended.
MANUAL OPERATION	Manual push button/Non-lock type
RATED VOLTAGE	<ul style="list-style-type: none"> • AC-100V 50/60Hz, 110V 60Hz • AC-200V 50/60Hz, 220V 60Hz • DC-24V • DC-100V
VOLTAGE ALLOWANCE	-15 ~ 10%
INSULATION GRADE	Class B

BASIC MODEL NOS. & OTHERS

Pipe Size	Function		MODEL NUMBER	Effective Area [mm ²] < Cv value >	Mass [kg]
	Position	Solenoid & Function	DIN type Connector		
Rc ^{1/4}	2 position	Single Solenoid	MVS-492-02Y	35 < 1.9 >	1.0
Rc ^{3/8}			MVS-492-03JY		
Rc ^{1/4}		Double Solenoid	MVD-492-02Y		1.2
Rc ^{3/8}			MVD-492-03JY		
Rc ^{1/4}	3 position	Closed Center	MVD-432-02Y		1.3
Rc ^{3/8}			MVD-432-03JY		
Rc ^{1/4}		Exhaust Center	MVD-442-02Y		
Rc ^{3/8}			MVD-442-03JY		
Rc ^{1/4}		Pressure Center	MVD-452-02Y		
Rc ^{3/8}			MVD-452-03JY		

HOW TO ORDER

MV - 4 2 - Y

PRODUCT TYPE: 492Y SERIES

- ① Nos. of Solenoid
S Single Solenoid
D Double Solenoid
- ② Positions & Function
9 2 position Single/Double
3 3 position Closed Center
4 3 position Exhaust Center
5 3 position Pressure Center
- ③ Pipe Size
02 Rc^{1/4}
03J Rc^{3/8} (over ported)
- ④ Solenoid Electricity
NIL For AC use (Std.)
H For DC use

- ⑤ Use
NIL Standard
- ⑥ Pilot Air Supply
NIL Internal pilot air supply
P External pilot air supply
- ⑦ Accessory
NIL Manual push button/Non-lock type
R Lock type manual operation button
S DIN connector with pilot lamp
- ⑧ Rated Voltage
AC-100V AC-100V 50/60Hz, 110V 60Hz
AC-200V AC-200V 50/60Hz, 220V 60Hz
DC-24V DC-24V
DC-100V DC-100V

MVS-492-02Y, 03JY

H-7501

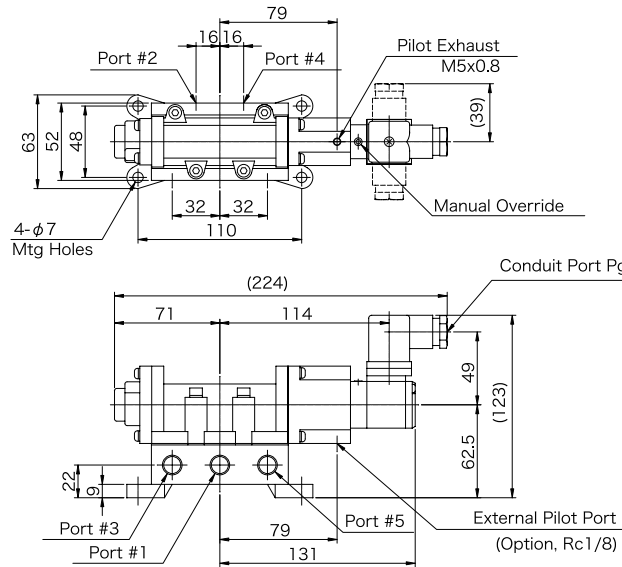
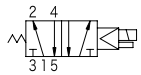

NOTE:
Pg11 connector is applicable to
cable of $\phi 6\sim 14$ mm OD.

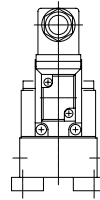

MVD-492-02Y, 03JY

H-7502

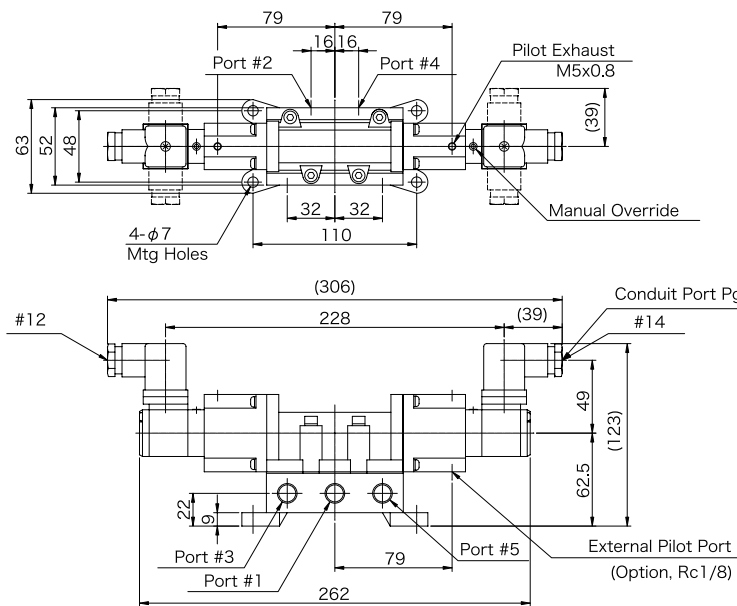
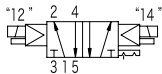

NOTE:
Pg11 connector is applicable to
cable of $\phi 6\sim 14$ mm OD.

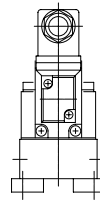

MVD-4 * 2-02Y, 03JY

H-7503

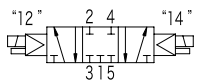

Closed Center
MVD-432-02Y, 03JY

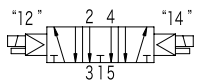

Exhaust Center
MVD-442-02Y, 03JY

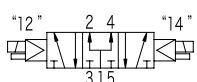

Pressure Center
MVD-452-02Y, 03JY

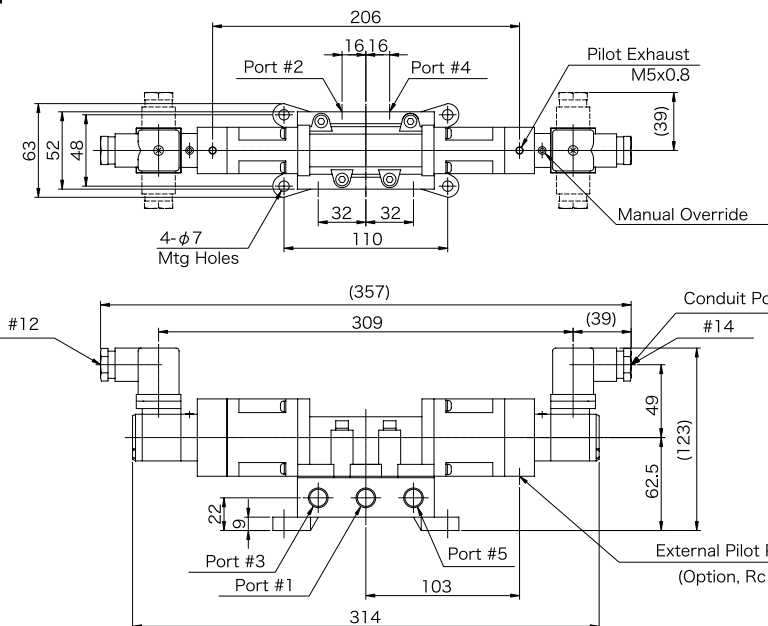

NOTE:
Pg11 connector is applicable to
cable of $\phi 6\sim 14$ mm OD.

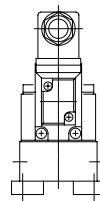

5 PORT SOLENOID VALVE

492Y SERIES

MANIFOLD TYPE

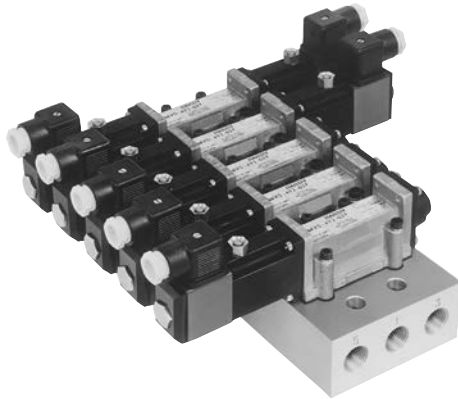

SPECIFICATIONS

Pipe Size	"1" "3" "5" port (common port)	Rc ¹ / ₂ (on manifold block)
	"2" "4" port (separate port)	Rc ¹ / ₄ or Rc ³ / ₈ (on manifold block)
Effective Area	35mm ²	
Maximum number of valves available for manifold	10	

* Other specifications are common to 492Y Series, Sub-base type.

HOW TO ORDER

MVF - 204Y × -

① ② ③ ④ ⑤ ⑥

Common port pipe size
"1" "3" "5" port: Rc¹/₂

PRODUCT TYPE: MANIFOLD 492Y SERIES

Note: Valves mounted on the same manifold block should have the same accessories.

① Nos. of valve fitted on manifold block

2 ~ 10 available

② Solenoid Electricity

NIL	AC use (Std.)
H	DC use

③ Pilot Air Supply

NIL	Internal pilot air supply
P	External pilot air supply

④ Accessory

NIL	Manual push button/Non-lock type
R	Manual operation button/Lock type
S	DIN type connector with pilot lamp

⑤ Specifying of Solenoid Valve to be mounted

Specify valves and accessories by letters in the following table. The valves mounting arrangement write down the letters in order from left side with viewing of following direction.

Return spring side of single solenoid valve and/or "12" solenoid side of double solenoid valve is placed towards this side with the manifold block underneath.

Letter	"2" "4" port	MODEL NUMBER	Function
1	Rc ¹ / ₄	MVS-492-02FY	Single Solenoid
6	Rc ³ / ₈		
2	Rc ¹ / ₄	MVD-492-02FY	Double Solenoid
7	Rc ³ / ₈		
3	Rc ¹ / ₄	MVD-432-02FY	3 position Closed Center
8	Rc ³ / ₈		
4	Rc ¹ / ₄	MVD-442-02FY	3 position Exhaust Center
9	Rc ³ / ₈		
5	Rc ¹ / ₄	MVD-452-02FY	3 position Pressure Center
0	Rc ³ / ₈		
Y		Plug plate	Plugging for use-less valve Mount

⑥ Rated Voltage

AC-100V	AC-100V 50/60Hz, 110V 60Hz
AC-200	AC-200V 50/60Hz, 220V 60Hz
DC-24V	DC-24V
DC-100V	DC-100V

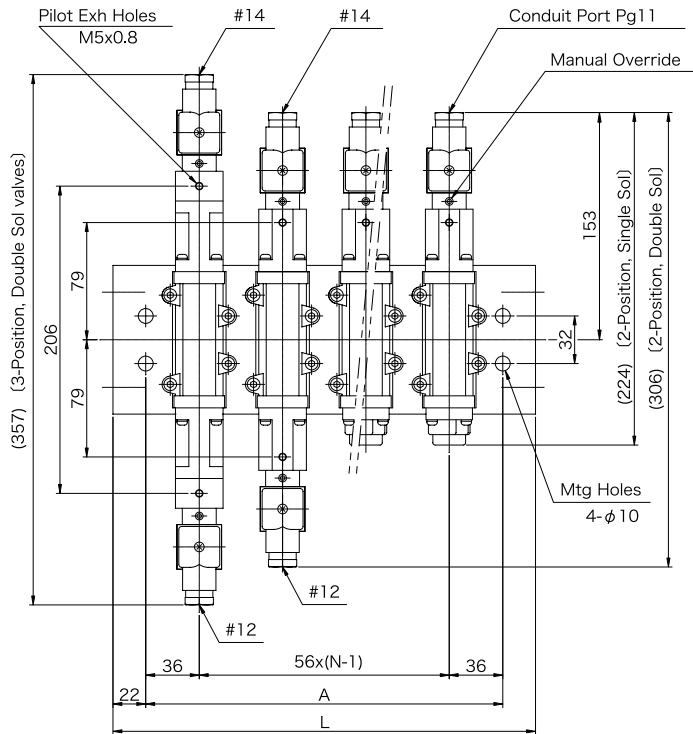

<Symbols of Valve Function>

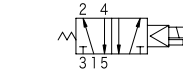

2-Position, Single
MVS-492-02FY

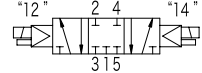

Closed Center
MVD-432-02FY

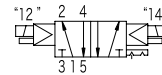

2-Position, Double
MVD-492-02FY

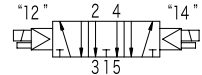

Exhaust Center
MVD-442-02FY

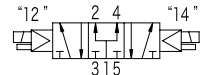

Pressure Center
MVD-452-02FY

<Dimensions>

N	2	3	4	5	6	7	8	9	10
A	128	184	240	296	352	408	464	520	576
L	172	228	284	340	396	452	508	564	620

N: Number of Valve Unit

A: Pitch of Mounting Holes

L: Length of Manifold Bed

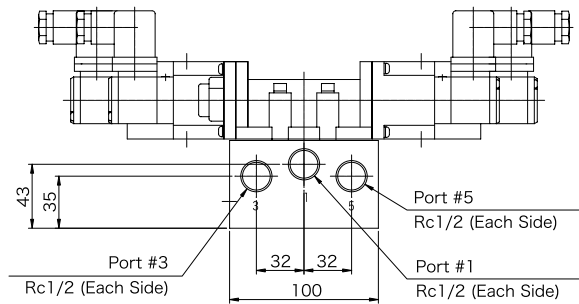
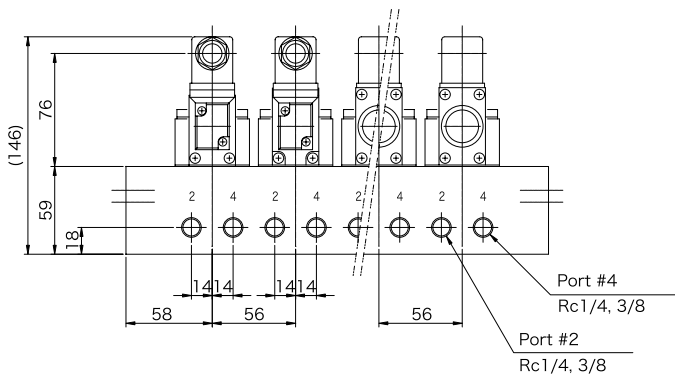

NOTE:

Pg11 DIN connector is applicable to cable of $\phi 6 \sim 10$ mm OD.

5 PORT SOLENOID VALVE

524 SERIES (Rc^{1/4}~Rc^{3/4})

SUB-BASE TYPE

Pilot operated spool valve

SPECIFICATIONS

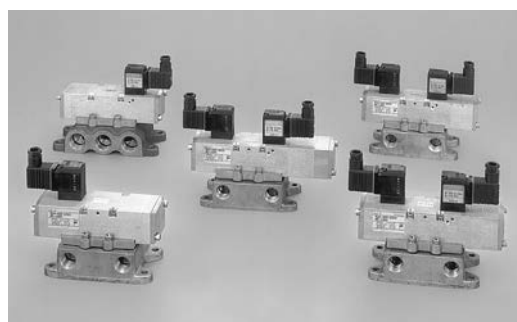

FLUID	Filtered Compressed Air
OPERATING PRESSURE	0.2 ~ 1.0MPa (Internal Pilot Supply type)
	0 ~ 1.0MPa (External Pilot Supply type)
AMBIENT TEMPERATURE	5 ~ 50°C
LUBRICANTS	ISO VG32 turbine oil, or equivalent oil is recommended.
MANUAL OPERATION	Manual push button/Non-lock type
RATED VOLTAGE	<ul style="list-style-type: none"> • AC-100V 50/60Hz, 110V 60Hz • AC-200V 50/60Hz, 220V 60Hz • DC-24V • DC-100V
VOLTAGE ALLOWANCE	-15 ~ 10%
INSULATION GRADE	Class B

BASIC MODEL NOS. & OTHERS

Pipe Size	Function		MODEL NUMBER	Effective Area [mm ²] < Cv value >	Mass [kg]
	Position	Solenoid & Function	DIN Type Connector		
Rc ^{1/4}	2 position	Single Solenoid	524-200-1000/1003	42 < 2.3 >	1.8
Rc ^{3/8}			524-300-1000/1003	68 < 3.7 >	
Rc ^{1/2}			524-400-1000/1003	80 < 4.3 >	
Rc ^{3/4}			524-600-1000/1003	80 < 4.3 >	
Rc ^{1/4}		Double Solenoid	524-200-2000/2003	42 < 2.3 >	2.0
Rc ^{3/8}			524-300-2000/2003	68 < 3.7 >	
Rc ^{1/2}			524-400-2000/2003	80 < 4.3 >	
Rc ^{3/4}			524-600-2000/2003	80 < 4.3 >	
Rc ^{1/4}	3 position	Closed Center	524-200-3000/3003	41 < 2.2 >	2.1
Rc ^{3/8}			524-300-3000/3003	60 < 3.3 >	
Rc ^{1/2}			524-400-3000/3003	75 < 4.1 >	
Rc ^{3/4}			524-600-3000/3003	75 < 4.1 >	
Rc ^{1/4}		Exhaust Center	524-200-4000/4003	41 < 2.2 >	2.1
Rc ^{3/8}			524-300-4000/4003	60 < 3.3 >	
Rc ^{1/2}			524-400-4000/4003	75 < 4.1 >	
Rc ^{3/4}			524-600-4000/4003	75 < 4.1 >	
Rc ^{1/4}		Pressure Center	524-200-5000/5003	41 < 2.2 >	2.1
Rc ^{3/8}			524-300-5000/5003	60 < 3.3 >	
Rc ^{1/2}			524-400-5000/5003	75 < 4.1 >	
Rc ^{3/4}			524-600-5000/5003	75 < 4.1 >	

HOW TO ORDER

5 2 4 - 4 0 0 - 1 0 0 3 AC-100V

① ② ③ ④ ⑤ ⑥ ⑦

PRODUCT TYPE:
5-PORT SOLENOID VALVE
524 SERIES

① Basic Body Size

4 | 1/2B Base

② Pipe Size

2 | Rc^{1/4}
3 | Rc^{3/8}
4 | Rc^{1/2}
5 | Rc^{3/4}

③ Positions & Function

1 | 2-Position Single
2 | 2-Position Double
3 | 3-Position Closed Center
4 | 3-Position Exhaust Center
5 | 3-Position Pressure Center

④ Pilot Air Supply

0 | Internal pilot air supply
1 | External pilot air supply

⑤ Accessory

0 | Non-lock push button
1 | Lock type push button

⑥ Elect. Conduit

0 | DIN. Pg 11 connector
2 | DIN. Pg 11 with lamp and surge killer
3 | DIN. Pg 9 connector
4 | DIN. Pg 9 with lamp and surge killer

⑦ Rated Voltage

AC-100V	AC-100V 50/60Hz, AC-110V 60Hz
AC-200V	AC-200V 50/60Hz, AC-220V 60Hz
DC-24V	
DC-100V	

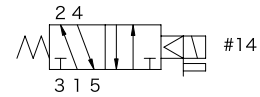
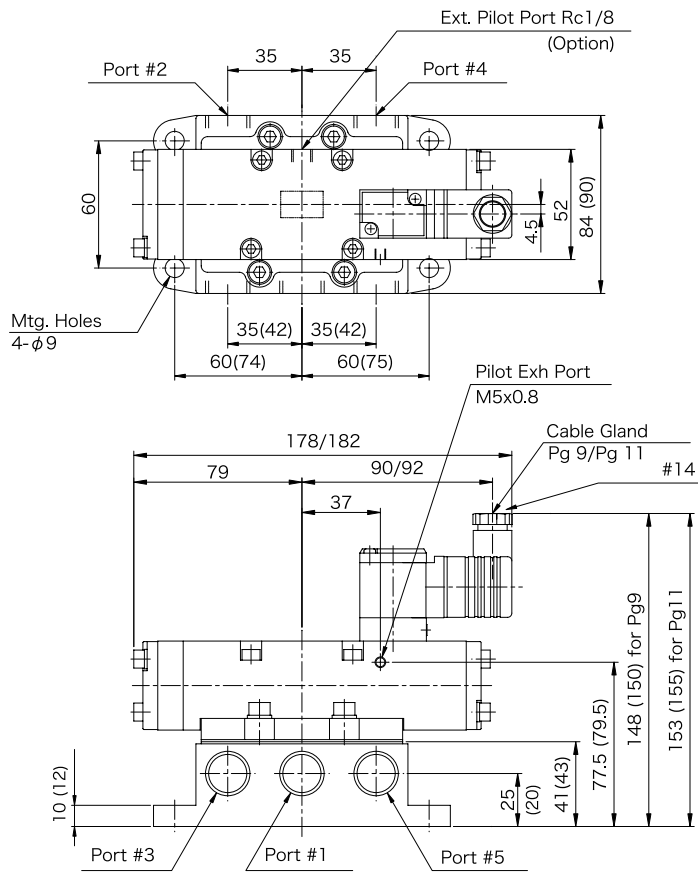

Pipe Size	MODEL No. (Internal Pilot Type)	
	Pg11 Connector	Pg9 Connector
Rc1/4	524-200-1000	524-200-1003
Rc3/8	524-300-1000	524-300-1003
Rc1/2	524-400-1000	524-400-1003
Rc3/4	524-600-1000	524-600-1003

Cable for Pg11: $\phi 6 \sim 10\text{mm}$
 Cable for Pg 9: $\phi 4.5 \sim 6\text{mm}$

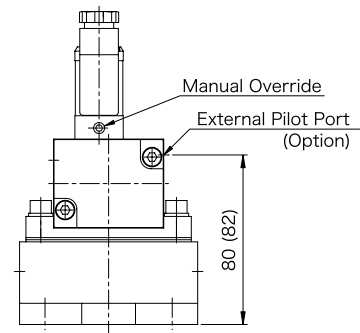

Dims in () are for Rc3/4 size.

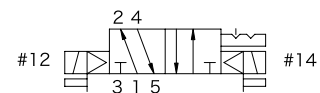
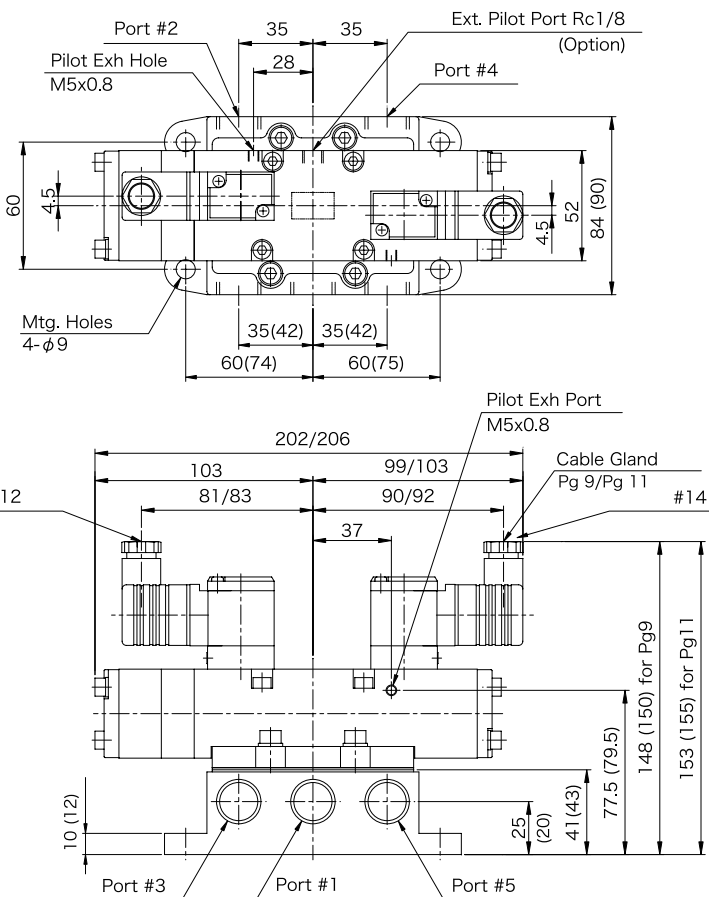

Pipe Size	MODEL No. (Internal Pilot Type)	
	Pg11 Connector	Pg9 Connector
Rc1/4	524-200-2000	524-200-2003
Rc3/8	524-300-2000	524-300-2003
Rc1/2	524-400-2000	524-400-2003
Rc3/4	524-600-2000	524-600-2003

Cable for Pg11: $\phi 6 \sim 10\text{mm}$
 Cable for Pg 9: $\phi 4.5 \sim 6\text{mm}$

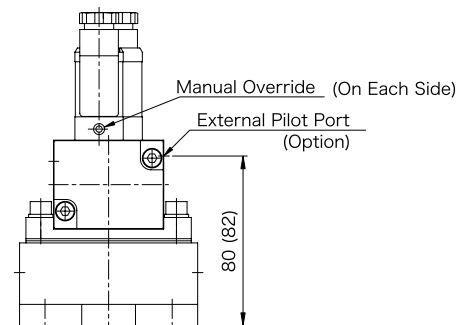

Dims in () are for Rc3/4 size.

5 PORT SOLENOID VALVE

524 SERIES MANIFOLD TYPE (524-6F0)

SPECIFICATIONS

Port Size	"1", "3", "5" common ports	Rc ³ / ₄
	"2", "4" Each valve port	Rc ³ / ₈ , Rc ¹ / ₂ or Rc ³ / ₄
Effective Area	75mm ²	
Maximum No. of valves available for manifold	6	

HOW TO ORDER

524 - 6F0 × 6LP - AC-100V

②③④

⑤

⑥

PRODUCT Series: 524 Manifold

② Nos. of valves composing manifold

2 ~ 6 available

③ Accessories of DIN Pg9 Connector Type(*)

NIL	Non-lock override button
S	Non-lock override button, and Pilot lamp w/surge killer

③ Accessories of DIN Pg11 Connector Type(*)

0	Non-lock override button
1	Non-lock override button, and Pilot lamp w/surge killer

④ Pilot Air Supply

NIL	Internal Pilot Supply (Std.)
P	External Pilot Supply

⑥ Rated Voltage

AC100V	AC100V 50/60Hz, 110V 60Hz
AC200V	AC200V 50/60Hz, 220V 60Hz
DC24V	DC24V
DC100V	DC100V

⑤ Specifying of Solenoid Valves for Manifold

Specify kind of valve and pipe size forming manifold by letters of the following table. Valve array of manifold can be directed with order of letters from left side of manifold with seeing manifold from following direction. It is the return spring side of single solenoid valve or "12" operator side of double solenoid valve is locating towards this side, in the condition locating manifold sub-base in underside.

Letter	"2", "4" Port	Model Numbers	Function
L	Rc ³ / ₈	524-000-100*	Single Solenoid
1	Rc ¹ / ₂		
6	Rc ³ / ₄		
M	Rc ³ / ₈	524-000-200*	Double Solenoid
2	Rc ¹ / ₂		
7	Rc ³ / ₄		
N	Rc ³ / ₈	524-000-300*	3 Position Closed Center
3	Rc ¹ / ₂		
8	Rc ³ / ₄		
R	Rc ³ / ₈	524-000-400*	3 Position Exhaust Center
4	Rc ¹ / ₂		
9	Rc ³ / ₄		
S	Rc ³ / ₈	524-000-500*	3 Position Pressure Center
5	Rc ¹ / ₂		
0	Rc ³ / ₄		
P	—	IN Port Block	Port block for additional IN port
Y	—	Separator	Plate for dividing common IN passage

(*) : Lockable override button available

DIMENSIONS

-mm-

310-046

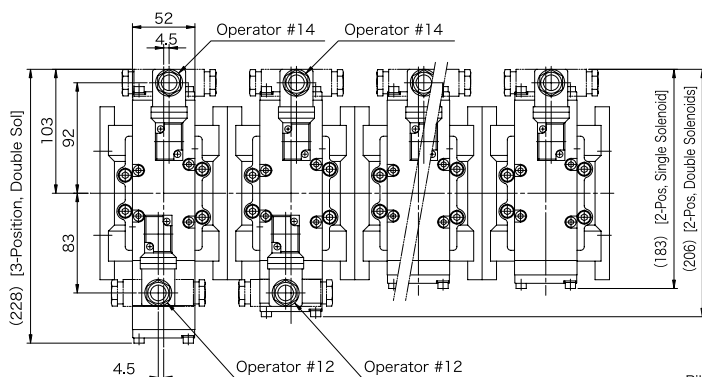

Dimensions of L -mm-

Number of valve units	2	3	4	5	6
Dims of L	212	318	424	530	636

Add 56 to L in case an auxiliary supply port block is inserted.
Add 10 to L in case a separator is inserted to divide air supply passage.

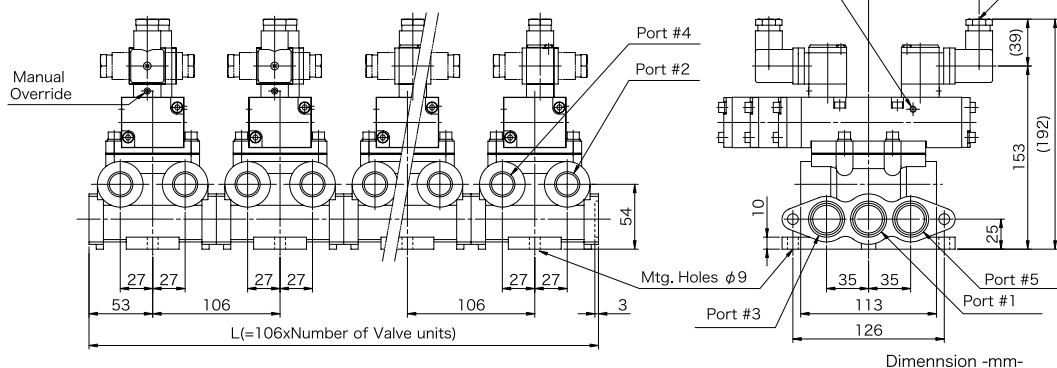

Dimension -mm-

5 PORT SOLENOID VALVE

492Y SERIES (Rc³/₄~Rc1¹/₄)

SUB-BASE TYPE

Pilot operated spool valve

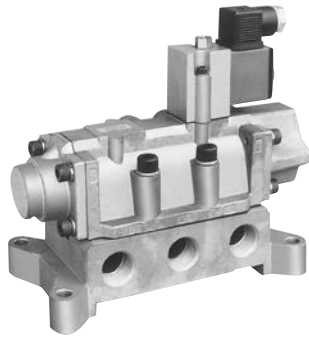

SPECIFICATIONS

FLUID	Filtered Compressed Air
OPERATING PRESSURE	0.15 ~ 1.0MPa (Internal Pilot Supply type)
	0 ~ 1.0MPa (External Pilot Supply type)
AMBIENT TEMPERATURE	5 ~ 50°C
LUBRICANTS	Turbine oil ISO VG 32 or equivalent oil is recommended.
MANUAL OPERATION	Manual push button/Non-lock type
RATED VOLTAGE	<ul style="list-style-type: none"> • AC-100V 50/60Hz, 110V 60Hz • AC-200V 50/60Hz, 220V 60Hz • DC-24V • DC-100V
VOLTAGE ALLOWANCE	-15 ~ 10%
INSULATION GRADE	Class B

BASIC MODEL NOS. & OTHERS

Pipe size	Function		MODEL NUMBER	Effective Area [mm ²] < Cv value >	Mass [kg]
	Position	Solenoid & Function			
Rc ³ / ₄	2 position	Single Solenoid	MVS-492-06Y	185 < 10.0 >	3.8
Rc1			MVS-492-10Y	195 < 10.7 >	
Rc1 ¹ / ₄			MVS-492-12JY	215 < 11.8 >	
Rc ³ / ₄		Double Solenoid	MVD-492-06Y	185 < 10.0 >	4.5
Rc1			MVD-492-10Y	195 < 10.7 >	
Rc1 ¹ / ₄			MVD-492-12JY	215 < 11.8 >	
Rc ³ / ₄	3 position	Closed Center	MVD-432-06Y	185 < 10.0 >	5.3
Rc1			MVD-432-10Y	195 < 10.7 >	
Rc1 ¹ / ₄			MVD-432-12JY	215 < 11.8 >	
Rc ³ / ₄		Exhaust Center	MVD-442-06Y	185 < 10.0 >	5.3
Rc1			MVD-442-10Y	195 < 10.7 >	
Rc1 ¹ / ₄			MVD-442-12JY	215 < 11.8 >	
Rc ³ / ₄		Pressure Center	MVD-452-06Y	185 < 10.0 >	5.3
Rc1			MVD-452-10Y	195 < 10.7 >	
Rc1 ¹ / ₄			MVD-452-12JY	215 < 11.8 >	

HOW TO ORDER

MV - 4 2 - Y

① ② ③ ④ ⑤ ⑥ ⑦ ⑧ ⑨ ⑩

NUMBER OF PORT

PRODUCT TYPE
SOLENOID VALVE 492Y SERIES

① Nos. of Solenoid

S	Single Solenoid
D	Double Solenoid

② Positions & Function

9	2 position Single/Double
3	3 position Closed Center
4	3 position Exhaust Center
5	3 position Pressure Center

③ Pipe Size

06	Rc ³ / ₄
10	Rc1
12J	Rc1 ¹ / ₄ (over port)

④ Solenoid Electricity

NIL	For AC use (Std.)
H	For DC use

⑤ Use

NIL	Standard
-----	----------

⑥ Pilot Air Supply type

NIL	Internal pilot air supply
P	External pilot air supply

⑦ Accessory

NIL	Manual push button/Non-lock type
R	Lock type manual operation button
S	DIN connector with pilot lamp

⑧ Electrical Connection

NIL	DIN terminal connection
-----	-------------------------

⑨ Rated Voltage

AC-100V	AC-100V 50/60Hz, 110V 60Hz
AC-200V	AC-200V 50/60Hz, 220V 60Hz
DC-24V	DC-24V
DC-100V	DC-100V

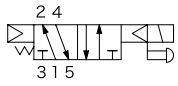

Single Solenoid type
MVS-492-06Y,10Y,12JY

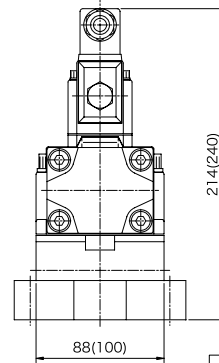
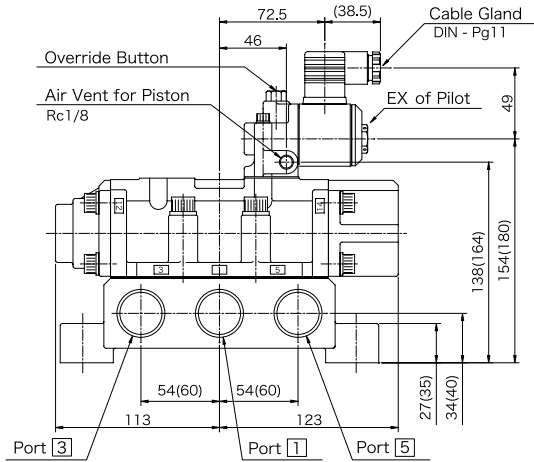
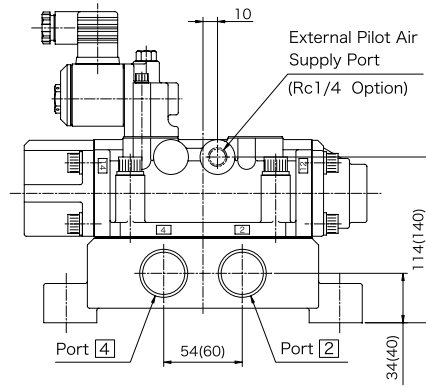
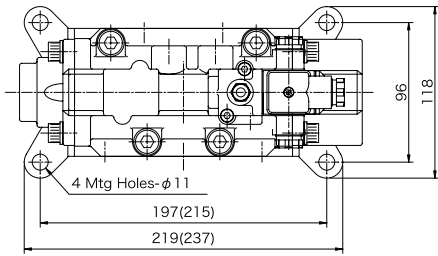

Model Numbers

Port Sizes	Single Sol. type
Rc3/4	MVS-492-06Y
Rc1	MVS-492-10Y
Rc1-1/4	MVS-492-12JY

NOTE : Size Rc1-1/4 unit uses another sub-base, which exchanges some dimensions by dimensions of (xx). Refer to the attached drawing.

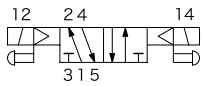

2-position, Double Solenoid type
MVD-492-06Y,10Y,12JY

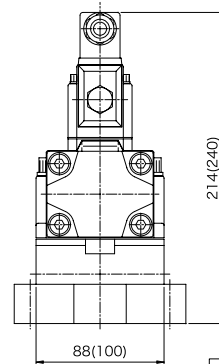
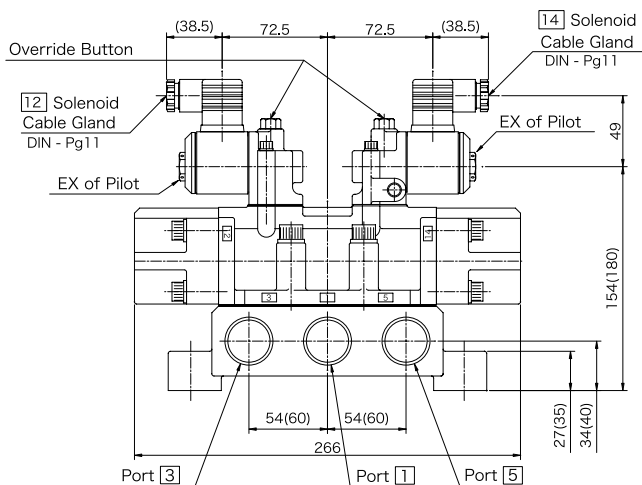
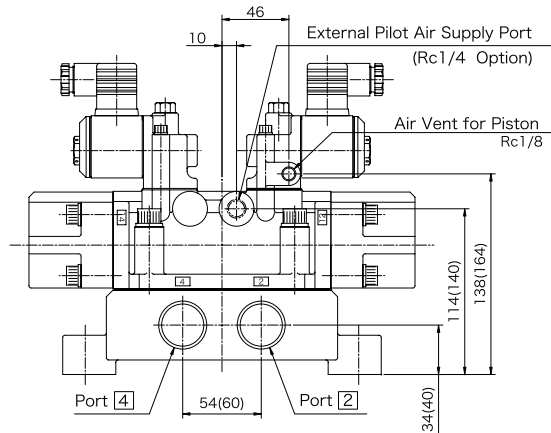
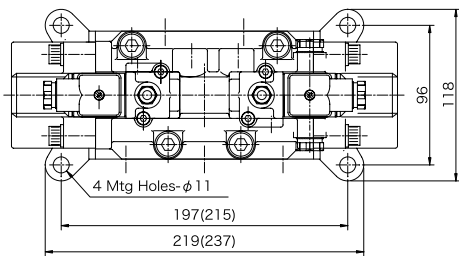

Model Numbers

Port Sizes	2-pos, Double Sol.
Rc3/4	MVD-492-06Y
Rc1	MVD-492-10Y
Rc1-1/4	MVD-492-12JY

NOTE : Size Rc1-1/4 unit uses another sub-base, which exchanges some dimensions by dimensions of (xx). Refer to the attached drawing.

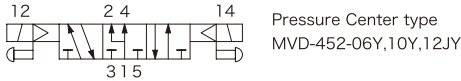
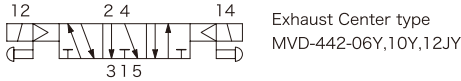
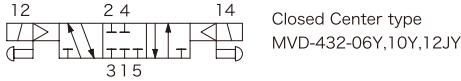

Model Numbers

Port Sizes	Closed Center	Exhaust Center	Pressure Center
Rc3/4	MVD-432-06Y	MVD-442-06Y	MVD-452-06Y
Rc1	MVD-432-10Y	MVD-442-10Y	MVD-452-10Y
Rc1-1/4	MVD-432-12JY	MVD-442-12JY	MVD-452-12JY

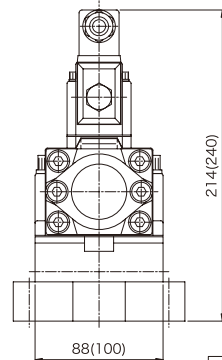
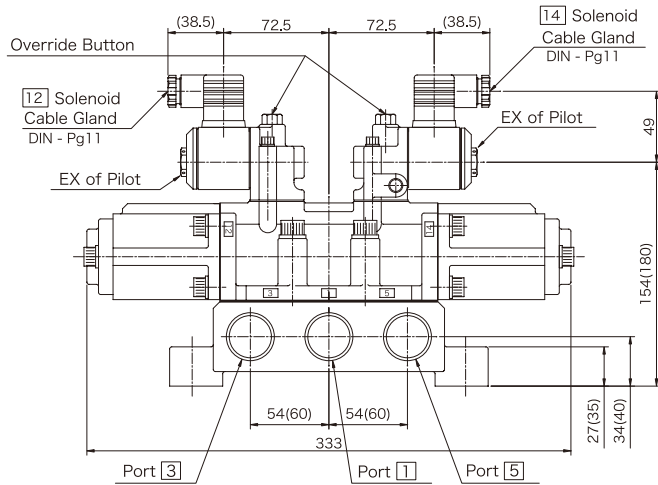
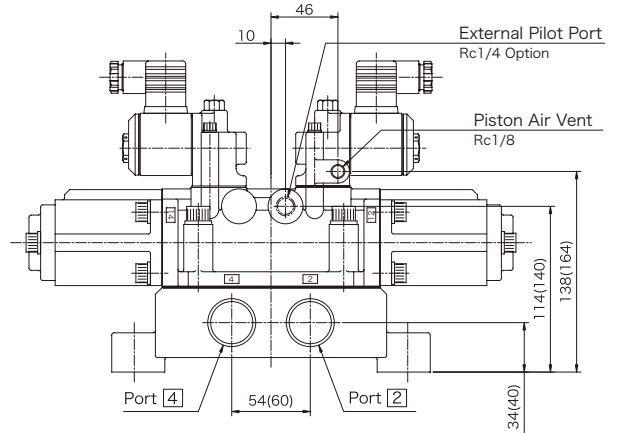
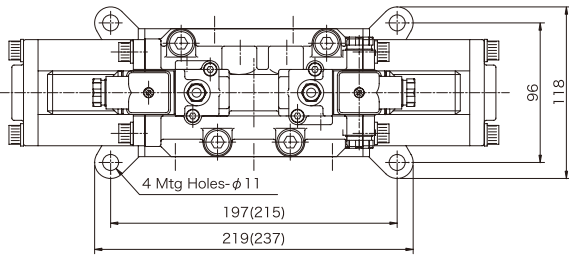

NOTE: Size Rc1-1/4 unit uses another sub-base, which exchanges some dimensions by dimensions of (xx). Refer to the attached drawing.

Attached Drawing for Size Rc1-1/4 Unit

Followings are applied to dimensions of size Rc1-1/4

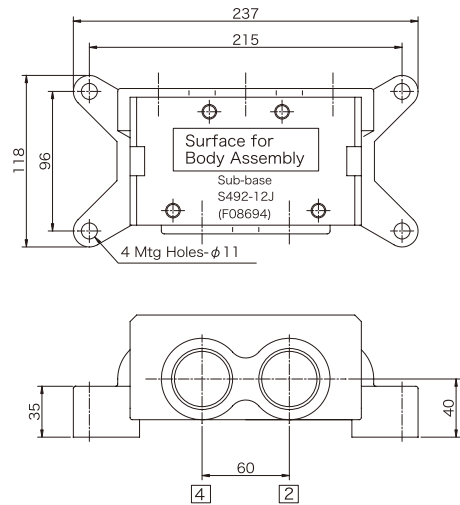
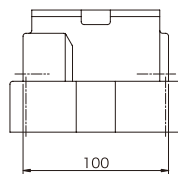
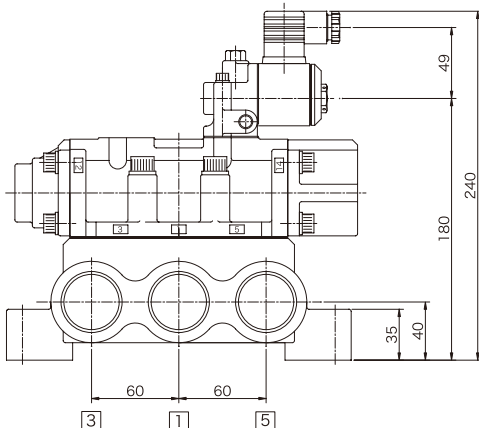

5 PORT SOLENOID VALVE

MVS-4900/MVD-4900 SERIES (Rc^{1/4}, Rc^{3/8})

IN-LINE TYPE

Directly operated spool valve

SPECIFICATIONS

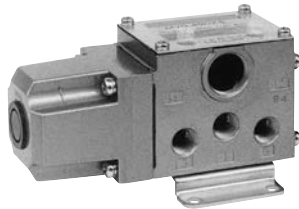

MVS-4900

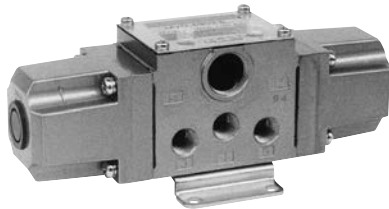

MVD-4900

FLUID	Filtered Compressed Air
OPERATING PRESSURE	0 ~ 1.0MPa
AMBIENT TEMPERATURE	5 ~ 50°C
LUBRICANTS	ISO VG32 turbine oil, or equivalent oil is recommended.
MANUAL OPERATION	Manual push button / Non-lock type
RATED VOLTAGE	<ul style="list-style-type: none"> • AC-100V 50/60Hz, 110V 60Hz • AC-200V 50/60Hz, 220V 60Hz • DC-24V • DC-100V
VOLTAGE ALLOWANCE	-15 ~ 10%
INSULATION GRADE	Class B

BASIC MODEL NOS. & OTHERS

Pipe Size	Function		MODEL NUMBER	Effective Area [mm ²] < Cv value >	Mass [kg] < DC >
Rc ^{1/4}	2 position	Single Solenoid	MVS-4902	9 < 0.49 >	1.0 < 1.4 >
Rc ^{3/8}			MVS-4903		
Rc ^{1/4}		Double Solenoid	MVD-4902	9 < 0.49 >	1.3 < 2.1 >
Rc ^{3/8}			MVD-4903		

HOW TO ORDER

MV - 4 9

① ② ③ ④ ⑤

PRODUCT TYPE: MVS-4900 SERIES

① Nos. of Solenoid

S | Single Solenoid
D | Double Solenoid

② Pipe Size

02 | Rc^{1/4}
03J | Rc^{3/8}

③ Solenoid Electricity

NIL | For AC use (Std.)
H | For DC use

④ Accessory

NIL | Manual push button / Non-lock type
R | Lock type manual operation button
S | Pilot lamp with surge killer

⑤ Rated Voltage

AC-100V	AC-100V 50/60Hz, 110V 60Hz
AC-200V	AC-200V 50/60Hz, 220V 60Hz
DC-24V	DC-24V
DC-100V	DC-100V

MVS-4900 Series & MVD-4900 Series

Port Sizes	MVS-4900 type	MVD-4900 type
	Single Solenoid	Double Solenoid
Rc1/4	MVS-4902	MVD-4902
Rc3/8	MVS-4903	MVD-4903

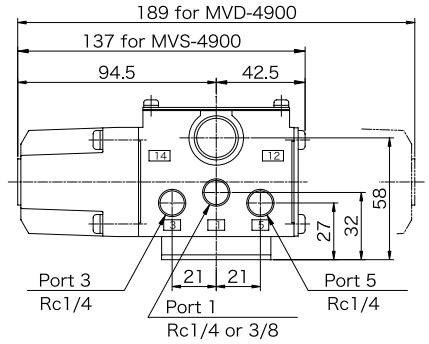
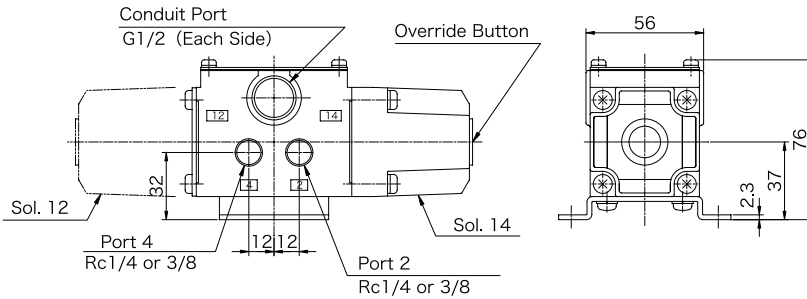
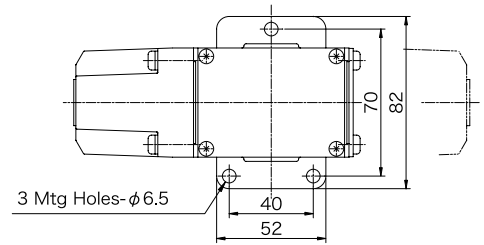

Dimensions of DC voltage type (MVS/MVD-4900H)

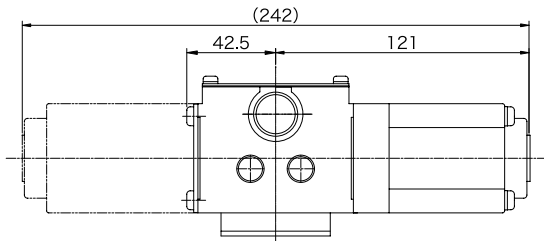

Dimensions with lockable override (MVS/MVD-4900R)

• For AC Voltage

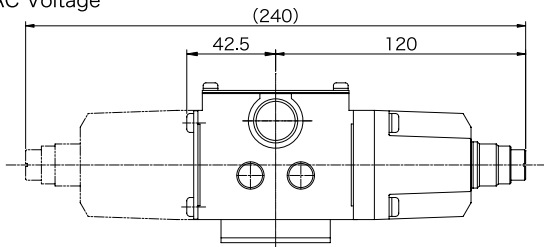

• For DC Voltage

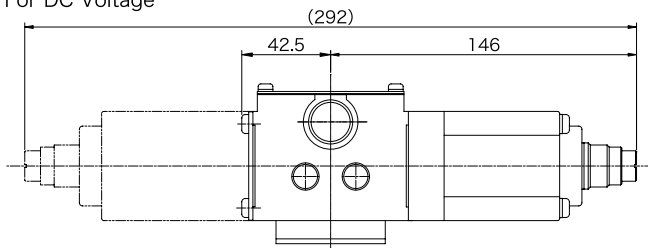

Dimensions with Pilot Lamp (MVS/MVD-4900S)

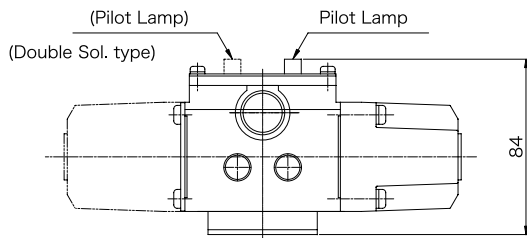

NOTE: Dimensions in () are applied to double sol. type valve. Others are common.

Usage of the Ports

When MVS/MVD-4900 is used as a 3-port solenoid valve.

■ Usage as normally closed type (NC)

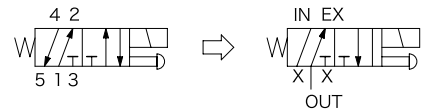

- * Use port-1 as port-OUT
- * Use port-4 as port-IN
- * Use port-2 as port-EX
- * Plug port-3 and port-5

■ Usage as normally open type (NO)

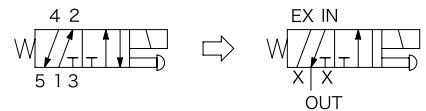

- * Use port-1 as port-OUT
- * Use port-2 as port-IN
- * Use port-4 as port-EX
- * Plug port-3 and port-5

■ Usage as 3-port double solenoid valve

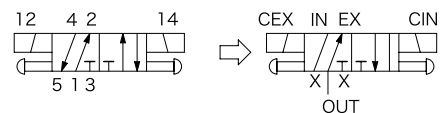

- * Use port-1 as port-OUT
- * Use port-4 as port-IN
- * Use port-2 as port-EX
- * Plug port-3 and port-5

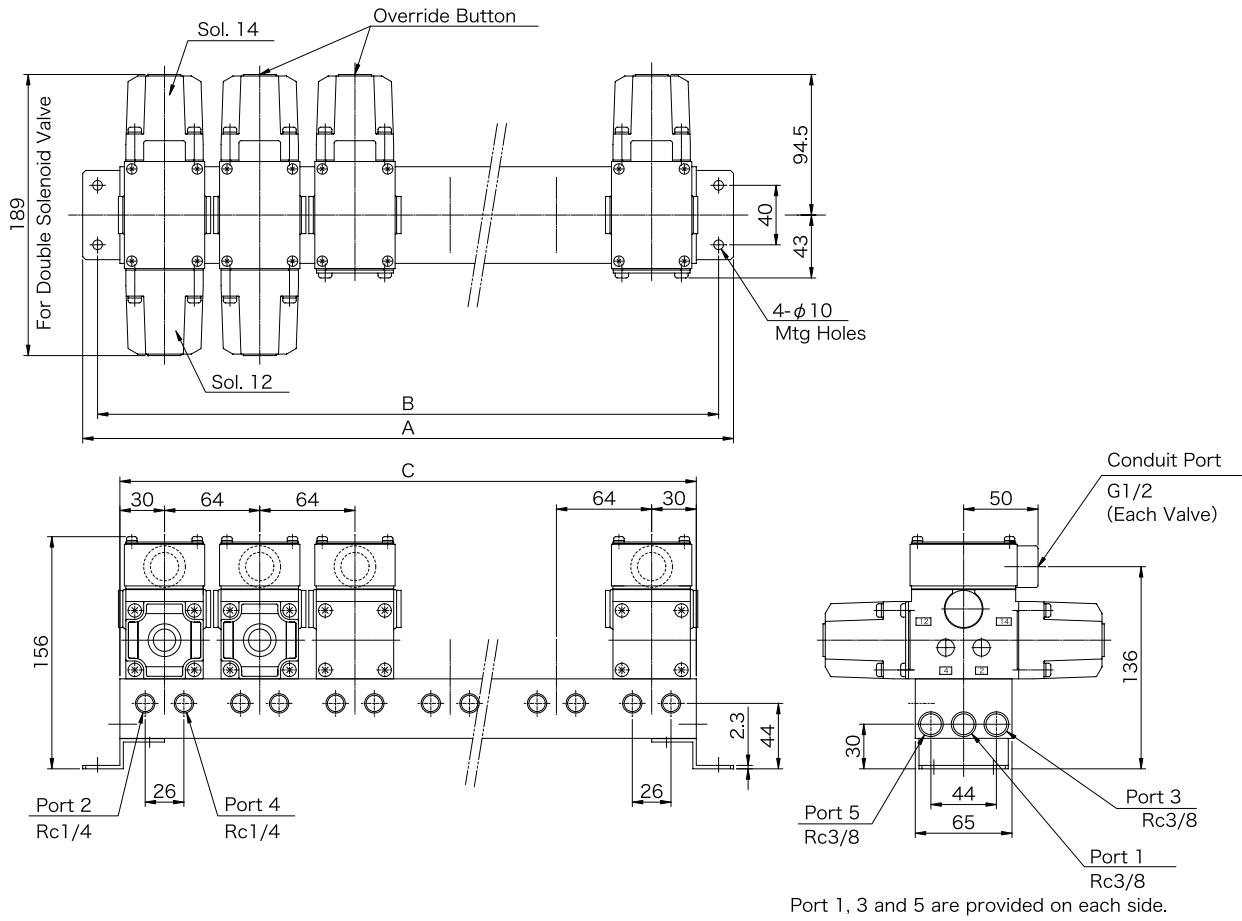

Dimensions of A, B, C -mm-

Number of valve units	2	3	4	5	6	7	8	9	10
A	174	238	302	366	430	494	558	622	686
B	154	218	282	346	410	474	538	602	666
C	124	188	252	316	380	444	508	572	636

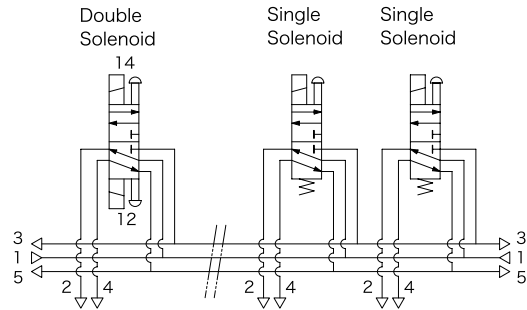

4 PORT SOLENOID VALVE

460 Super Poppet SERIES (Rc¹/₄~Rc2)

IN-LINE TYPE

Poppet valve

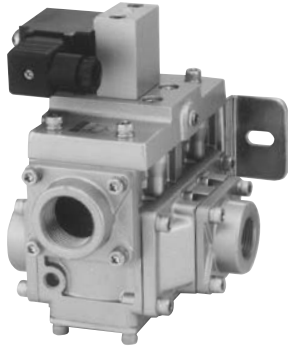

SINGLE SOLENOID

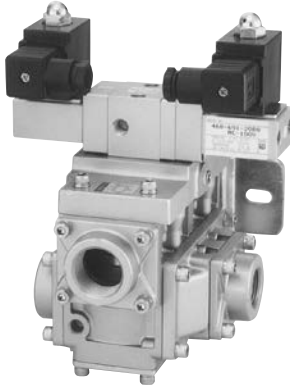

DOUBLE SOLENOID

SPECIFICATIONS

FLUID	Filtered Compressed Air
OPERATING PRESSURE	0.15 ~ 1.0MPa (Internal Pilot Supply type)
	0.05 ~ 1.0MPa (External Pilot Supply type)
AMBIENT TEMPERATURE	5 ~ 50°C
PROOF PRESSURE	1.6MPa
LUBRICANTS	ISO VG32 turbine oil, or equivalent oil is recommended.
MANUAL OPERATION	Manual push button/Non-lock type
RATED VOLTAGE	<ul style="list-style-type: none"> • AC-100V 50/60Hz, 110V 60Hz • AC-200V 50/60Hz, 220V 60Hz • DC-24V • DC-100V
VOLTAGE ALLOWANCE	-15 ~ 10%
INSULATION GRADE	Class B

BASIC MODEL NOS. & OTHERS

Port Size		MODEL NUMBER				Effective Area [mm ²] <Cv value>			
IN OUT	EX	Single Solenoid	Mass [kg]	Double Solenoid	Mass [kg]	IN-OUT		OUT-EX	
						IN→01	IN→02	01→EX	02→EX
Rc ¹ / ₄	Rc ¹ / ₂	463-201-10B0	1.8	463-201-20B0	1.9	42.5<2.3>	42.5<2.3>	53< 2.9>	53< 2.9>
Rc ³ / ₈		463-301-10B0		463-301-20B0		56< 3.0>	56< 3.0>	67< 3.6>	80< 4.3>
Rc ¹ / ₂		463-401-10B0		463-401-20B0		60< 3.2>	67< 3.6>	71< 3.8>	90< 4.9>
Rc ¹ / ₂	Rc1	468-401-10B0	3.5	468-401-20B0	3.6	112< 6.1>	118< 6.4>	150< 8.1>	160< 8.6>
Rc ³ / ₄		468-601-10B0		468-601-20B0		160< 8.6>	170< 9.2>	190<10.2>	180< 9.7>
Rc1		468-801-10B0		468-801-20B0		180< 9.7>	190<10.2>	190<10.2>	200<10.8>
Rc ¹ / ₄	Rc ¹ / ₄	468-A01-10B0		468-A01-20B0		180< 9.7>	190<10.2>	190<10.2>	200<10.8>
Rc ¹ / ₄	Rc2	46B-A00-10B0	11.5	46B-A00-20B0	12.1	400<21.6>	450<24.3>	425<23.0>	530<28.6>
Rc ¹ / ₂		46B-B00-10B0		46B-B00-20B0		480<25.9>	500<27.0>	500<27.0>	560<30.3>
Rc2		46B-C00-10B0		46B-C00-20B0		480<25.9>	530<28.6>	500<27.0>	560<30.3>

HOW TO ORDER

46 8 - 8 0 1 - 1 0 B 0 AC-100V

③ ④ ⑦ ⑧ ⑨ ⑩ ⑪

PRODUCT TYPE: 460 SERIES

③ Basic Body Size

- 3 3/8" Basic
- 8 1" Basic
- B 1 1/2" Basic

④ Main Pipe Size

- 2 Rc¹/₄
- 3 Rc³/₈
- 4 Rc¹/₂
- 6 Rc³/₄
- 8 Rc1
- A Rc¹/₄
- B Rc¹/₂
- C Rc2

⑦ Function

- 1 Single solenoid, Normally open
- 2 Double solenoid

⑧ Pilot Air Supply

- 0 Internal Pilot Air Supply (Std.)
- 1 External Pilot Air Supply

⑨ Accessory

- B Manual push button/Non-lock type mounting bracket
- R Lock type manual operation button mounting bracket

⑩ Type of Operator

- 0 Solenoid (Std.)
- 2 Solenoid with indicator and surge killer

⑪ Rated Voltage

AC-100V	AC-100V 50/60Hz, 110V 60Hz
AC-200V	AC-200V 50/60Hz, 220V 60Hz
DC-24V	DC-24V
DC-100V	DC-100V

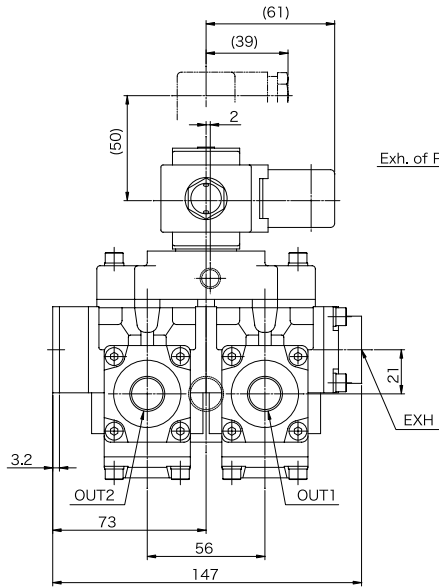
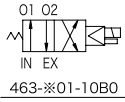

Port Sizes of Each Model

Model Numbers	IN & OUT	EX
463-201-10B0	Rc1/4	Rc1/2
463-301-10B0	Rc3/8	
463-401-10B0	Rc1/2	

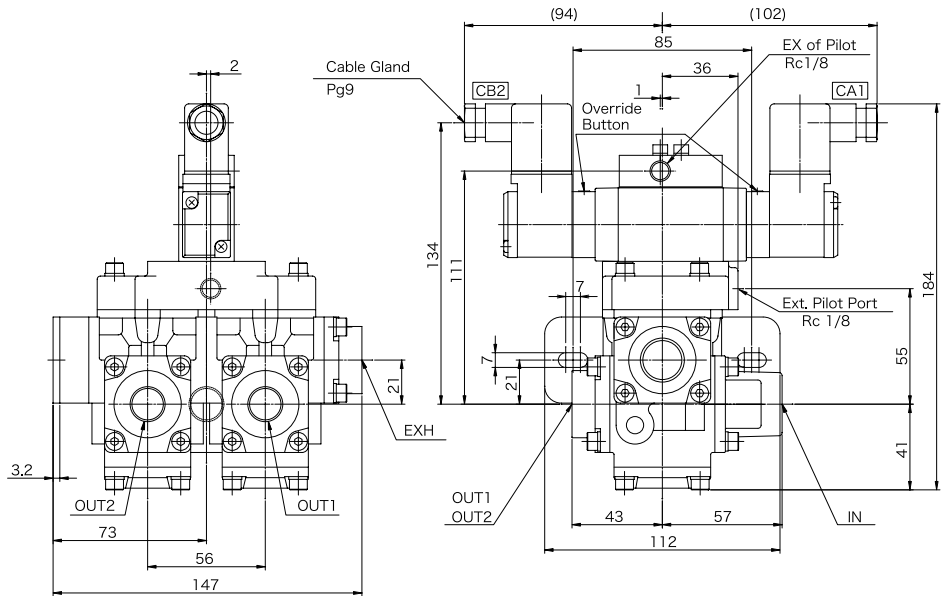
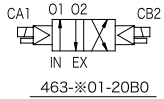
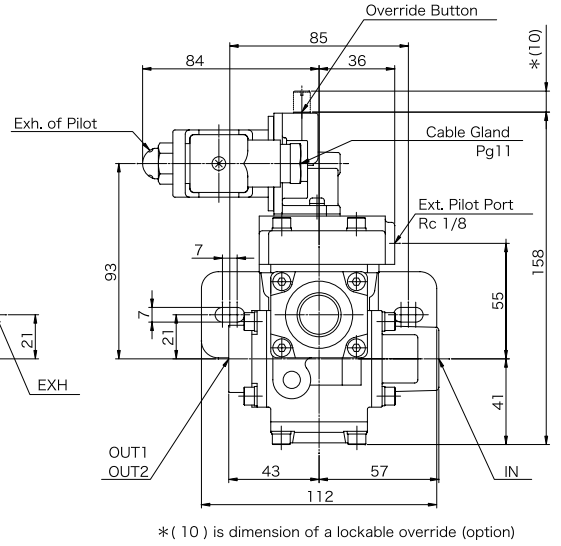

Port Sizes of Each Model

Model Numbers	IN & OUT	EX
463-201-20B0	Rc1/4	Rc1/2
463-301-20B0	Rc3/8	
463-401-20B0	Rc1/2	

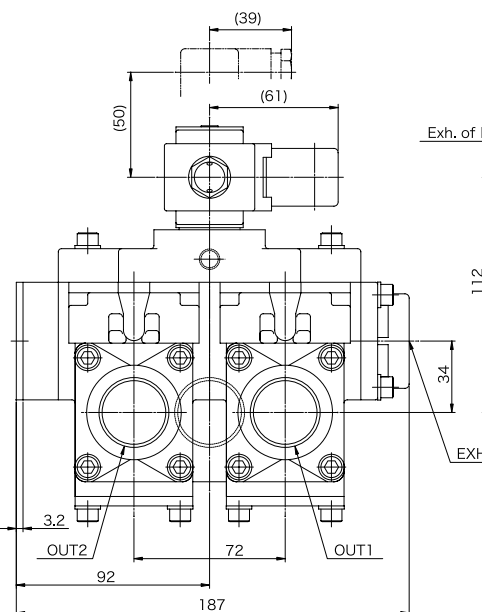
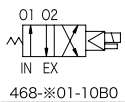
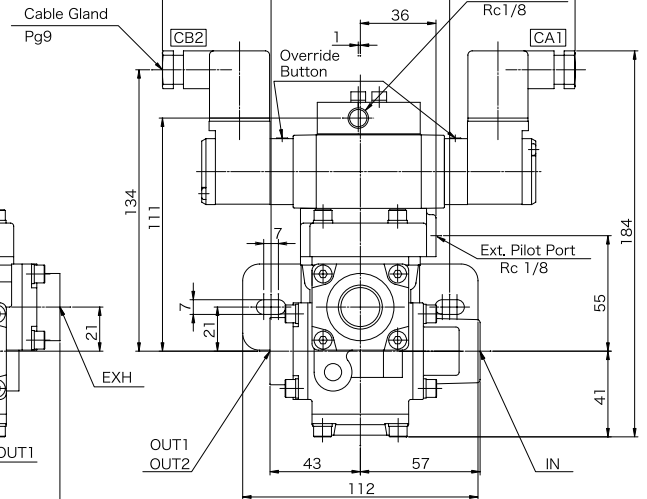

Port Sizes of Each Model

Model Numbers	IN & OUT	EX
468-401-10B0	Rc1/2	Rc1
468-601-10B0	Rc3/4	
468-801-10B0	Rc1	
468-A01-10B0	Rc1-1/4	Rc1-1/4

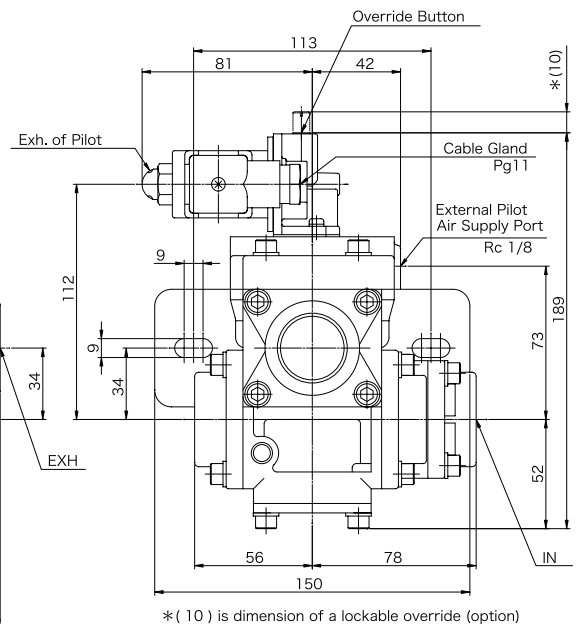

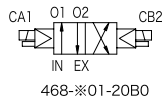

Port Sizes of Each Model

Model Numbers	IN & OUT	EX
468-401-20B0	Rc1/2	Rc1
468-601-20B0	Rc3/4	
468-801-20B0	Rc1	Rc1-1/4
468-A01-20B0	Rc1-1/4	

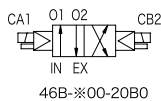
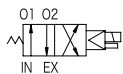
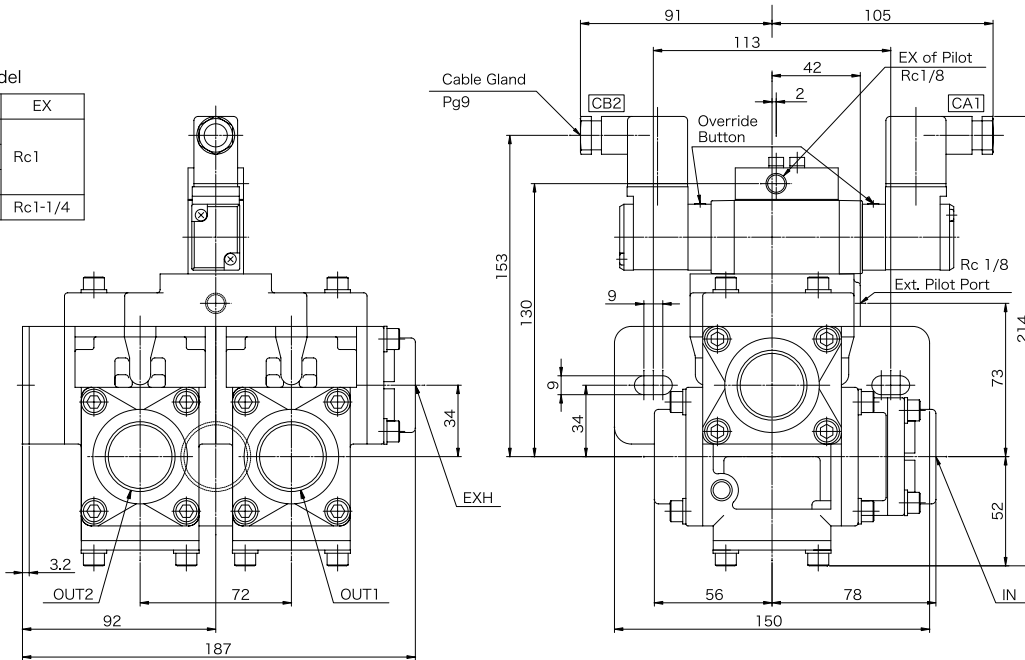

Port Sizes of Each Model

Model Numbers	IN & OUT	EX
46B-A00-10B0/20B0	Rc1-1/4	Rc2
46B-B00-10B0/20B0	Rc1-1/2	
46B-C00-10B0/20B0	Rc2	

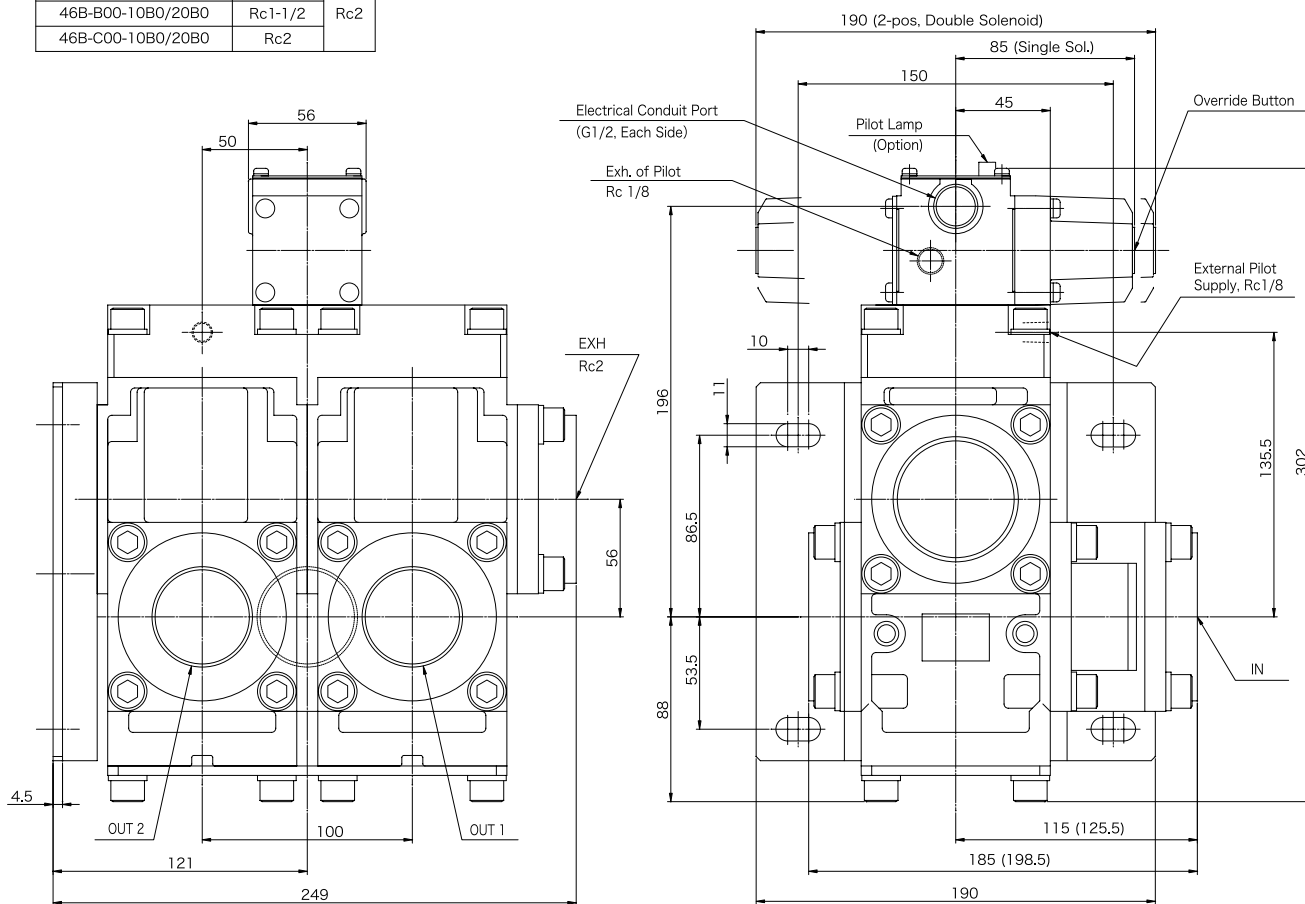

Dimensions in () are for 46B-C00 unit.

4 PORT SOLENOID VALVE

460 Super Poppet SERIES (Rc¹/₄~Rc₂)

3-POSITION IN-LINE TYPE

Pilot operated poppet valve

SPECIFICATIONS

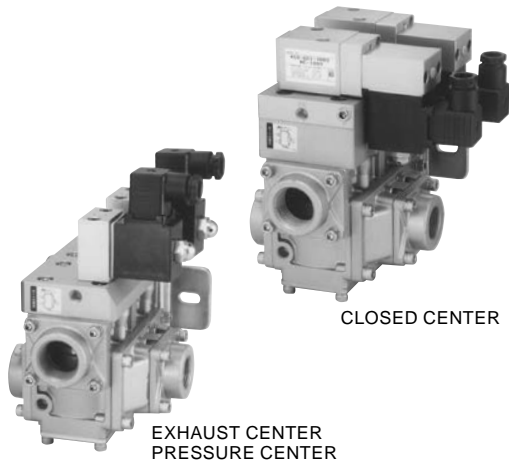

FLUID	Filtered Compressed Air
OPERATING PRESSURE	0.15 ~ 1.0MPa (Internal Pilot Supply type)
	0.05 ~ 1.0MPa (External Pilot Supply type)
AMBIENT TEMPERATURE	5 ~ 50°C
PROOF PRESSURE	1.6MPa
LUBRICANTS	ISO VG32 turbine oil, or equivalent oil is recommended.
MANUAL OPERATION	Manual push button/Non-lock type
RATED VOLTAGE	<ul style="list-style-type: none"> • AC-100V 50/60Hz, 110V 60Hz • AC-200V 50/60Hz, 220V 60Hz • DC-24V • DC-100V
VOLTAGE ALLOWANCE	-15 ~ 10%
INSULATION GRADE	Class B

BASIC MODEL NOS. & OTHERS

Port Size		Function	MODEL NUMBER	Effective Area (mm ²) < Cv value >				Mass [kg]
IN-OUT	EX			IN-01	IN-02	01-EX	02-EX	
Rc ¹ / ₄	Rc ¹ / ₂	Closed Center	463-201-30B0	43< 2.3>	43< 2.3>	58< 3.1>	56< 3.0>	2.9
Rc ³ / ₈			463-301-30B0	63< 3.4>	63< 3.4>	88< 4.7>	73< 3.9>	
Rc ¹ / ₂	Rc1		463-401-30B0	76< 4.1>	76< 4.1>	100< 5.4>	80< 4.3>	5.2
Rc ¹ / ₂			468-401-30B0	124< 6.7>	124< 6.7>	175< 9.4>	150< 8.1>	
Rc ³ / ₄	Rc ¹ / ₄		468-601-30B0	175< 9.4>	175< 9.4>	250<13.5>	180< 9.7>	15.3
Rc1			468-801-30B0	200<10.8>	200<10.8>	282<15.2>	195<10.5>	
Rc ¹ / ₄	Rc2		468-A01-30B0	200<10.8>	200<10.8>	282<15.4>	186<10.0>	4.1
Rc ¹ / ₂			46B-A00-31B0	540<29.2>	540<29.2>	590<31.9>	380<20.5>	
Rc ¹ / ₂	Rc ¹ / ₄		46B-B00-31B0	540<29.2>	540<29.2>	630<34.0>	380<20.5>	12.2
Rc2			46B-C00-31B0	545<29.5>	545<29.5>	680<36.7>	390<21.1>	
Rc ¹ / ₄	Rc ¹ / ₄		463-201-40B0	37< 2.0>	37< 2.0>	41< 2.2>	40< 2.1>	2.3
Rc ³ / ₈			463-301-40B0	58< 3.1>	58< 3.1>	78< 4.2>	65< 3.5>	
Rc ¹ / ₂	Rc1		463-401-40B0	70< 3.7>	70< 3.7>	104< 5.6>	75< 4.0>	4.1
Rc ¹ / ₂			468-401-40B0	122< 6.5>	122< 6.5>	170< 9.1>	130< 7.0>	
Rc ³ / ₄	Rc ¹ / ₄		468-601-40B0	170< 9.1>	170< 9.1>	245<13.2>	145< 7.8>	12.2
Rc1			468-801-40B0	195<10.5>	195<10.5>	280<15.1>	150< 8.1>	
Rc ¹ / ₄	Rc2		468-A01-40B0	196<10.5>	196<10.5>	280<15.1>	150< 8.1>	4.1
Rc ¹ / ₂			46B-A00-41B0	450<24.3>	450<24.3>	540<29.2>	265<14.3>	
Rc ¹ / ₂	Rc ¹ / ₄		46B-B00-41B0	510<27.6>	510<27.6>	645<34.9>	270<14.6>	12.2
Rc2			46B-C00-41B0	525<28.4>	525<28.4>	680<36.7>	270<14.6>	
Rc ¹ / ₄	Rc ¹ / ₂		463-201-50B0	35< 1.8>	35< 1.8>	40< 2.1>	40< 2.1>	2.3
Rc ³ / ₈			463-301-50B0	50< 2.7>	50< 2.7>	66< 3.5>	64< 3.4>	
Rc ¹ / ₂	Rc1		463-401-50B0	53< 2.8>	53< 2.8>	73< 3.9>	70< 4.0>	4.1
Rc ¹ / ₂			468-401-50B0	120< 6.4>	120< 6.4>	153< 8.2>	145< 7.8>	
Rc ³ / ₄	Rc ¹ / ₄		468-601-50B0	175< 9.4>	175< 9.4>	185<10.0>	170< 9.1>	12.2
Rc1			468-801-50B0	190<10.2>	200<10.8>	200<10.8>	180< 9.7>	
Rc ¹ / ₄	Rc2		468-A01-50B0	184< 9.9>	192<10.3>	198<10.7>	177< 9.5>	12.2
Rc ¹ / ₂			46B-A00-51B0	450<24.3>	460<24.9>	470<25.4>	450<24.3>	
Rc ¹ / ₂	Rc2		46B-B00-51B0	510<27.6>	510<27.6>	515<27.8>	480<25.9>	12.2
Rc2			46B-C00-51B0	510<27.6>	510<27.6>	540<29.2>	500<27.0>	

HOW TO ORDER

468-801-30B0 AC-100V

③ ④ ⑦ ⑧ ⑨ ⑩ ⑪

PRODUCT TYPE: 460 SERIES

③ Basic Body Size

- 3 3/8" Basic
- 8 1" Basic
- B 1 1/2" Basic

④ Main Pipe Size

- 2 Rc¹/₄
- 3 Rc³/₈
- 4 Rc¹/₂
- 6 Rc³/₄
- 8 Rc1
- A Rc¹/₄
- B Rc¹/₂
- C Rc2

⑦ Function

- 3 Closed Center
- 4 Exhaust Center
- 5 Pressure Center

⑧ Pilot Air Supply

- 0 Internal Pilot Air Supply (Std.)
- 1 External Pilot Air Supply

⑨ Accessory

- B Manual push button/Non-lock type mounting bracket
- R Lock type manual operation button mounting bracket

⑩ Type of Operator

- 0 Solenoid (Std.)
- 2 Solenoid with indicator and surge killer

⑪ Rated Voltage

- | | |
|---------|----------------------------|
| AC-100V | AC-100V 50/60Hz, 110V 60Hz |
| AC-200V | AC-200V 50/60Hz, 220V 60Hz |
| DC-24V | DC-24V |
| DC-100V | DC-100V |

DIMENSIONS

—mm—

460 Series 3-Position, Closed Center

310-080-1

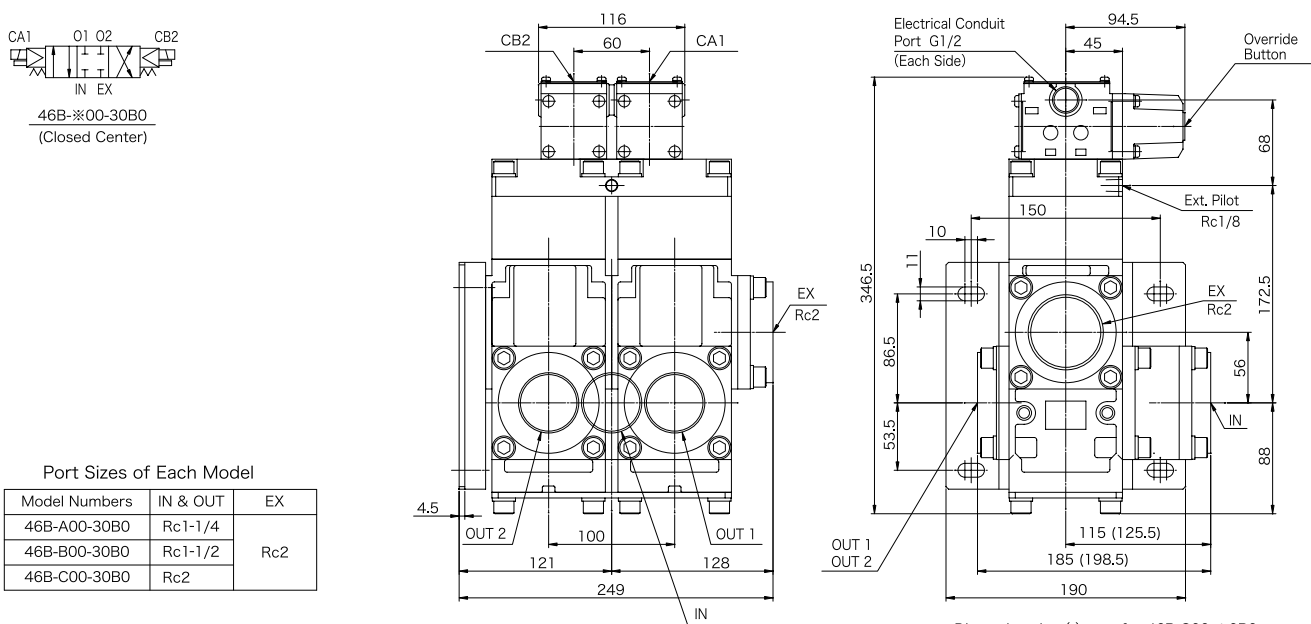
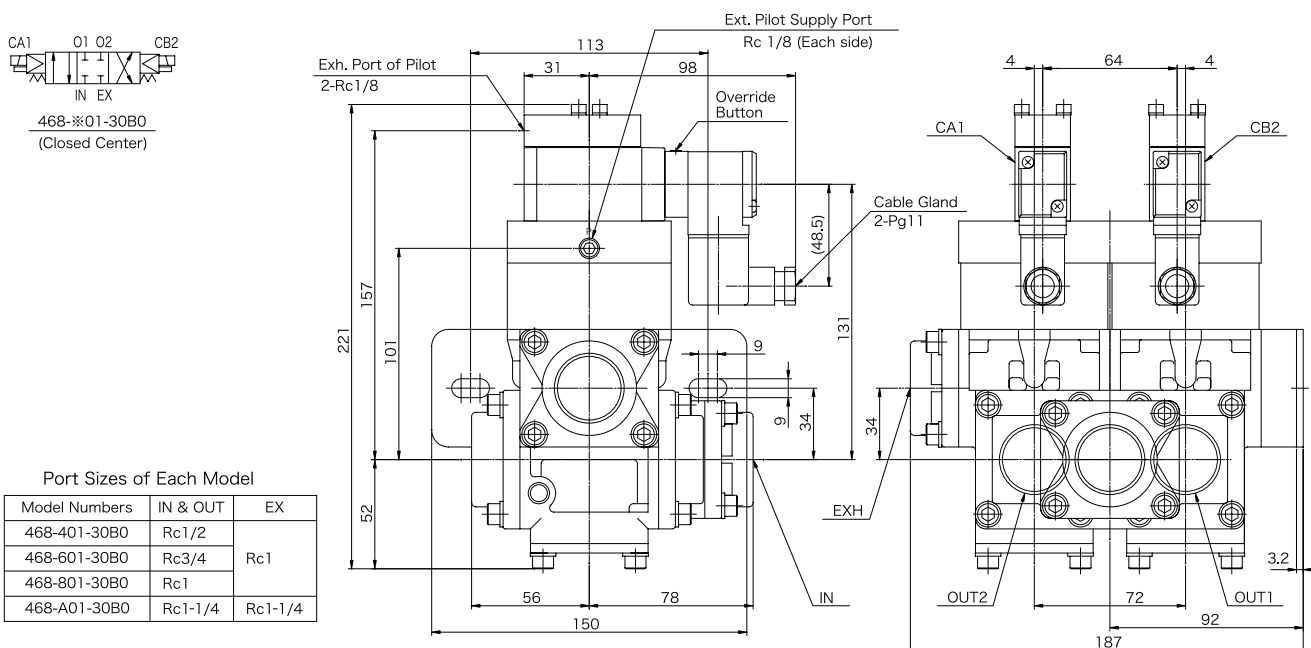
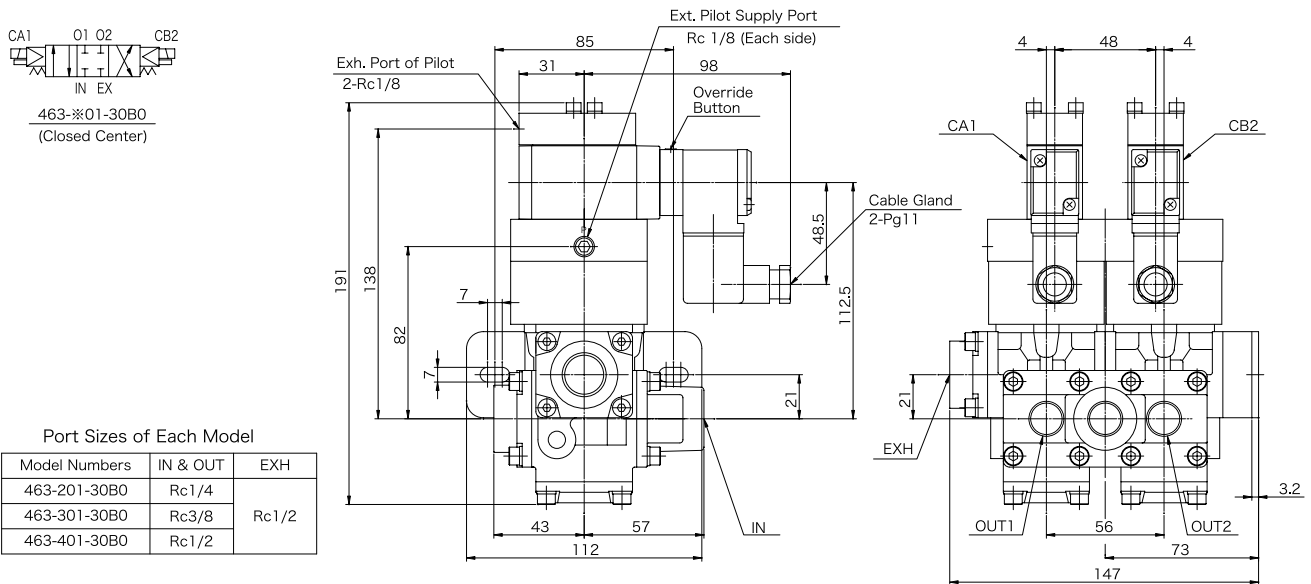

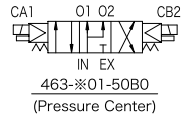
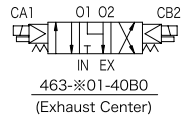

Port Sizes of Each Model

Model Numbers	IN & OUT	EXH
463-201-40B0/50B0	Rc1/4	Rc1/2
463-301-40B0/50B0	Rc3/8	
463-401-40B0/50B0	Rc1/2	

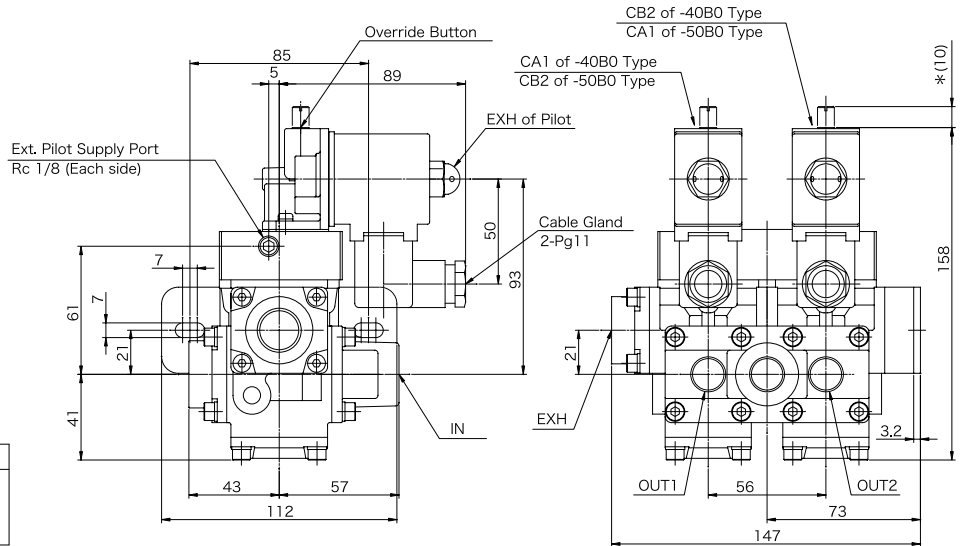

*(10) is dimension of a lockable override (option)

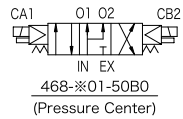
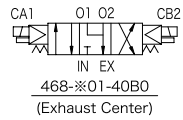

Port Sizes of Each Model

Model Numbers	IN & OUT	EX
468-401-40B0/50B0	Rc1/2	Rc1
468-601-40B0/50B0	Rc3/4	
468-801-40B0/50B0	Rc1	
468-A01-40B0/50B0	Rc1-1/4	

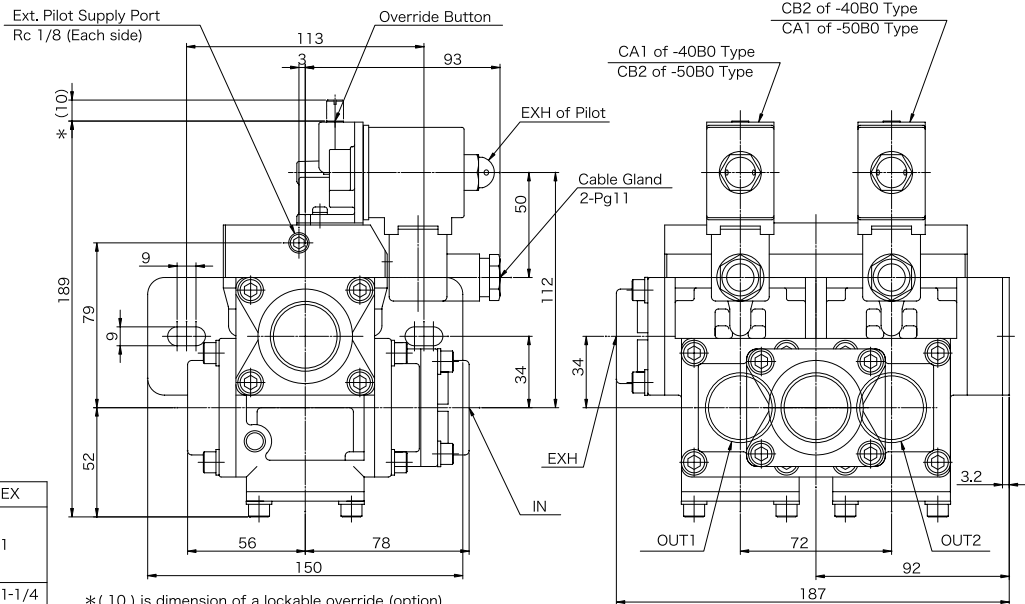

*(10) is dimension of a lockable override (option)

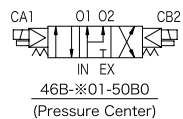
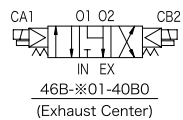

Port Sizes of Each Model

Model Numbers	IN & OUT	EX
46B-A00-40B0/50B0	Rc1-1/4	Rc2
46B-B00-40B0/50B0	Rc1-1/2	
46B-C00-40B0/50B0	Rc2	

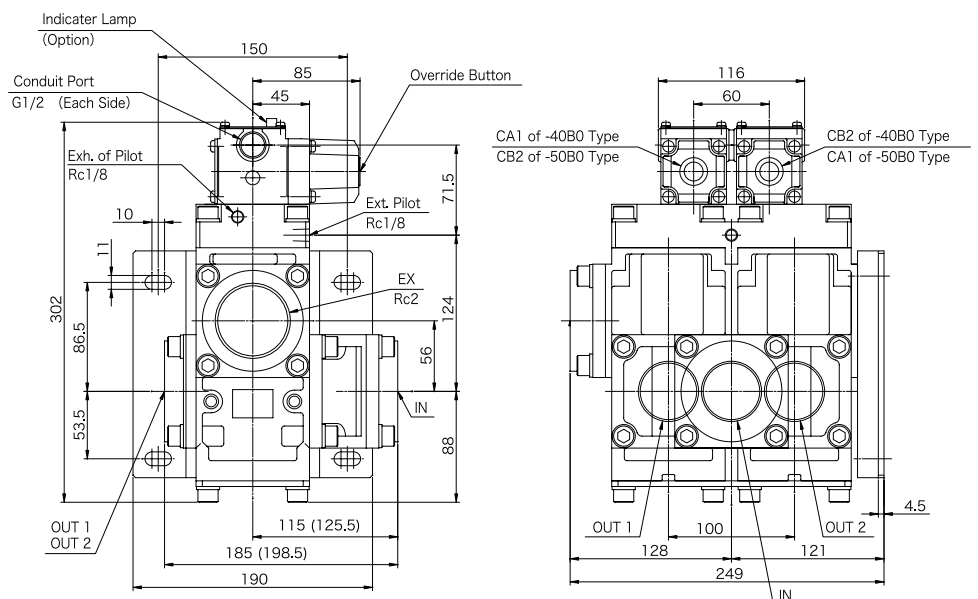

Dimensions in () are for 46B-C00-0B0

(CAD data of 46B was modified by x0,6 for fitting indication)

3 PORT SOLENOID VALVE

360 Super Poppet SERIES (Rc¹/₄~Rc2)

IN-LINE TYPE

Pilot operated poppet valve

SPECIFICATIONS

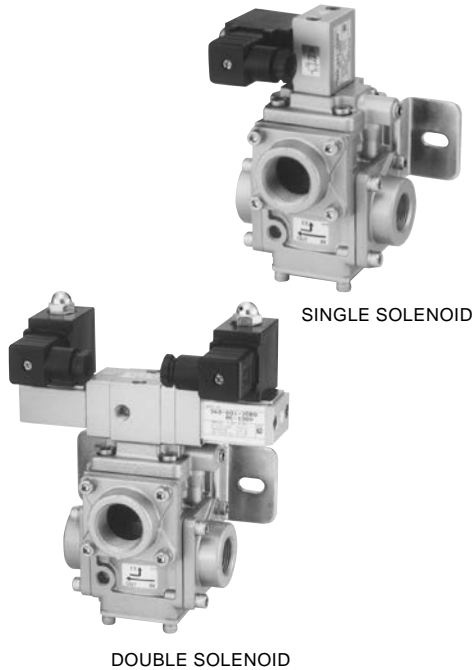

FLUID	Filtered Compressed Air
OPERATING PRESSURE	0.15 ~ 1.0MPa (Internal Pilot Supply type)
	0.05 ~ 1.0MPa (External Pilot Supply type)
AMBIENT TEMPERATURE	5 ~ 50°C
PROOF PRESSURE	1.6MPa
LUBRICANTS	ISO VG32 turbine oil, or equivalent oil is recommended.
MANUAL OPERATION	Manual push button/Non-lock type
RATED VOLTAGE	<ul style="list-style-type: none"> • AC-100V 50/60Hz, 110V 60Hz • AC-200V 50/60Hz, 220V 60Hz • DC-24V • DC-100V
VOLTAGE ALLOWANCE	-15 ~ 10%
INSULATION GRADE	Class B

BASIC MODEL NOS. & OTHERS

Port Size		MODEL NUMBER					Effective Area [mm ²] <Cv value>			
		Single Solenoid		* Mass [kg]	Double Solenoid	* Mass [kg]	Normally Closed & Double Solenoid		Normally Open	
IN OUT	EX	Normally Closed	Normally Open				IN-OUT	OUT-EX	IN-OUT	OUT-EX
Rc ¹ / ₄		363-201-00B0	363-201-10B0	1.1	363-201-20B0	1.2	42.5<2.3>	56< 3.0>	47.5<2.6>	56< 3.0>
Rc ³ / ₈	Rc ¹ / ₂	363-301-00B0	363-301-10B0		363-301-20B0		63< 3.4>	85< 4.6>	60< 3.2>	71< 3.8>
Rc ¹ / ₂		363-401-00B0	363-401-10B0		363-401-20B0		75< 4.1>	100< 5.4>	63< 3.4>	71< 3.8>
Rc ¹ / ₂		368-401-00B0	368-401-10B0	1.8	368-401-20B0	1.9	106< 5.7>	160< 8.6>	112< 6.1>	140< 7.6>
Rc ³ / ₄	Rc1	368-601-00B0	368-601-10B0		368-601-20B0		170< 9.2>	236<12.8>	150< 8.1>	176< 9.5>
Rc1		368-801-00B0	368-801-10B0		368-801-20B0		190<10.2>	250<13.5>	190<10.2>	180< 9.7>
Rc1 ¹ / ₄	Rc1 ¹ / ₄	368-A01-00B0	368-A01-10B0		368-A01-20B0		190<10.2>	250<13.5>	190<10.2>	180< 9.7>
Rc1 ¹ / ₄		36B-A00-00B0	36B-A00-10B0	6.2	36B-A00-20B0	6.8	450<24.3>	530<28.6>	400<21.6>	425<23.0>
Rc1 ¹ / ₂	Rc2	36B-B00-00B0	36B-B00-10B0		36B-B00-20B0		500<27.0>	600<32.4>	480<25.9>	500<27.0>
Rc2		36B-C00-00B0	36B-C00-10B0		36B-C00-20B0		530<28.6>	600<32.4>	480<25.9>	500<27.0>

HOW TO ORDER

368-801-00B0 AC-100V

③ ④ ⑦ ⑧ ⑨ ⑩ ⑪

PRODUCT TYPE: 360 SERIES

③ Basic Body Size

- 3 3/8" Basic
- 8 1" Basic
- B 1 1/2" Basic

④ Main Pipe Size

- 2 Rc¹/₄
- 3 Rc³/₈
- 4 Rc¹/₂
- 6 Rc³/₄
- 8 Rc1
- A Rc1¹/₄
- B Rc1¹/₂
- C Rc2

⑦ Function

- 0 Single solenoid,
Normally closed
- 1 Single solenoid,
Normally open
- 2 Double solenoid

⑧ Pilot Air Supply

- 0 Internal Pilot Air Supply (Std.)
- 1 External Pilot Air Supply

⑨ Accessory

- B Manual push button/Non-lock type
mounting bracket
- R Lock type manual operation button
mounting bracket

⑩ Type of Operator

- 0 Solenoid (Std.)
- 2 Solenoid with indicator and surge
killer

⑪ Rated Voltage

- | | |
|---------|----------------------------|
| AC-100V | AC-100V 50/60Hz, 110V 60Hz |
| AC-200V | AC-200V 50/60Hz, 220V 60Hz |
| DC-24V | DC-24V |
| DC-100V | DC-100V |

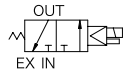

363-※01-00B0
(Normally Closed)

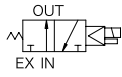

363-※01-10B0
(Normally Open)

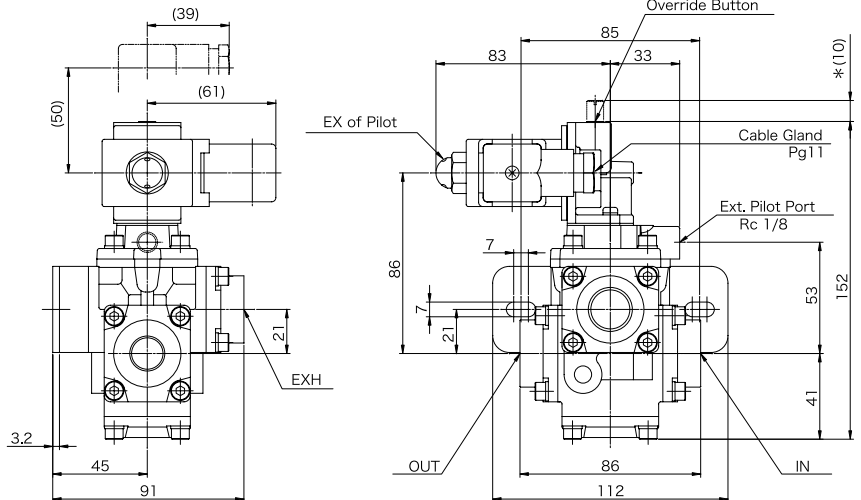

*(10) is dimension of a lockable override (option)

Port Sizes of Each Model

Model Numbers	IN & OUT	EX
363-201-00B0/10B0	Rc1/4	Rc1/2
363-301-00B0/10B0	Rc3/8	
363-401-00B0/10B0	Rc1/2	

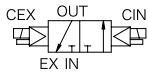

363-※01-20B0
(Double Solenoid)

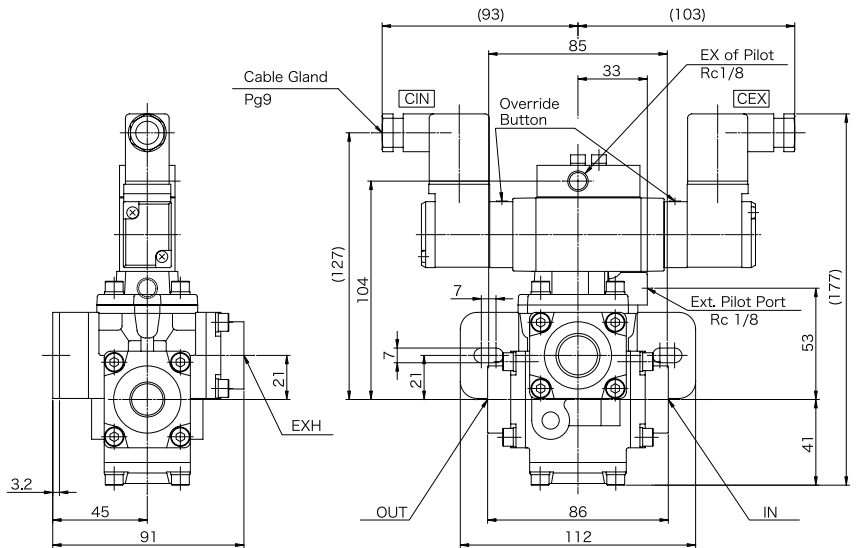

Port Sizes of Each Model

Model Numbers	IN & OUT	EX
363-201-20B0	Rc1/4	Rc1
363-301-20B0	Rc3/8	
363-401-20B0	Rc1/2	

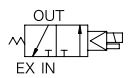

368-※01-00B0
(Normally Closed)

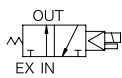

368-※01-10B0
(Normally Open)

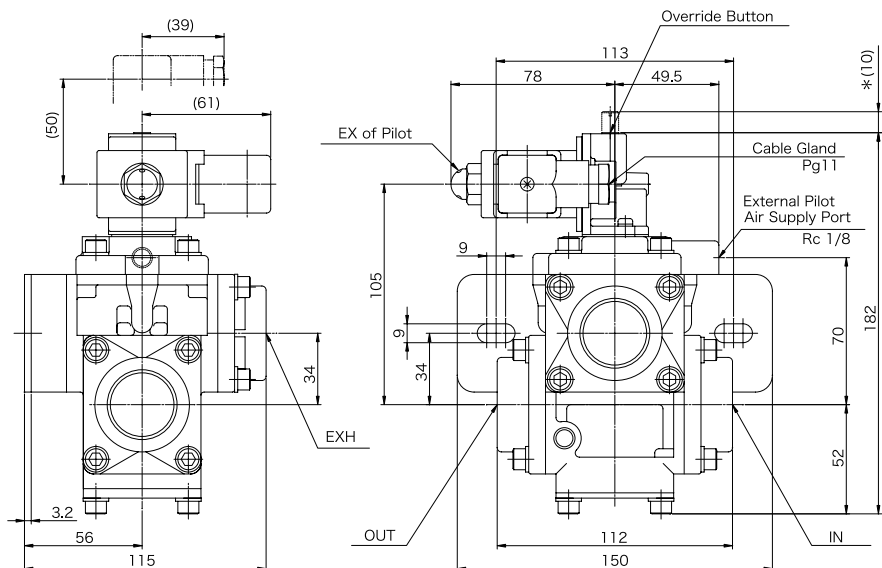

*(10) is dimension of a lockable override (option)

Port Sizes of Each Model

Model Numbers	IN & OUT	EX
368-401-00B0/10B0	Rc1/2	Rc1
368-601-00B0/10B0	Rc3/4	
368-801-00B0/10B0	Rc1	
368-A01-00B0/10B0	Rc1-1/4	Rc1-1/4

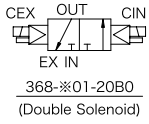

Port Sizes of Each Model

Model Numbers	IN & OUT	EX
368-401-20B0	Rc1/2	Rc1
368-601-20B0	Rc3/4	
368-801-20B0	Rc1	
368-A01-20B0	Rc1-1/4	Rc1-1/4

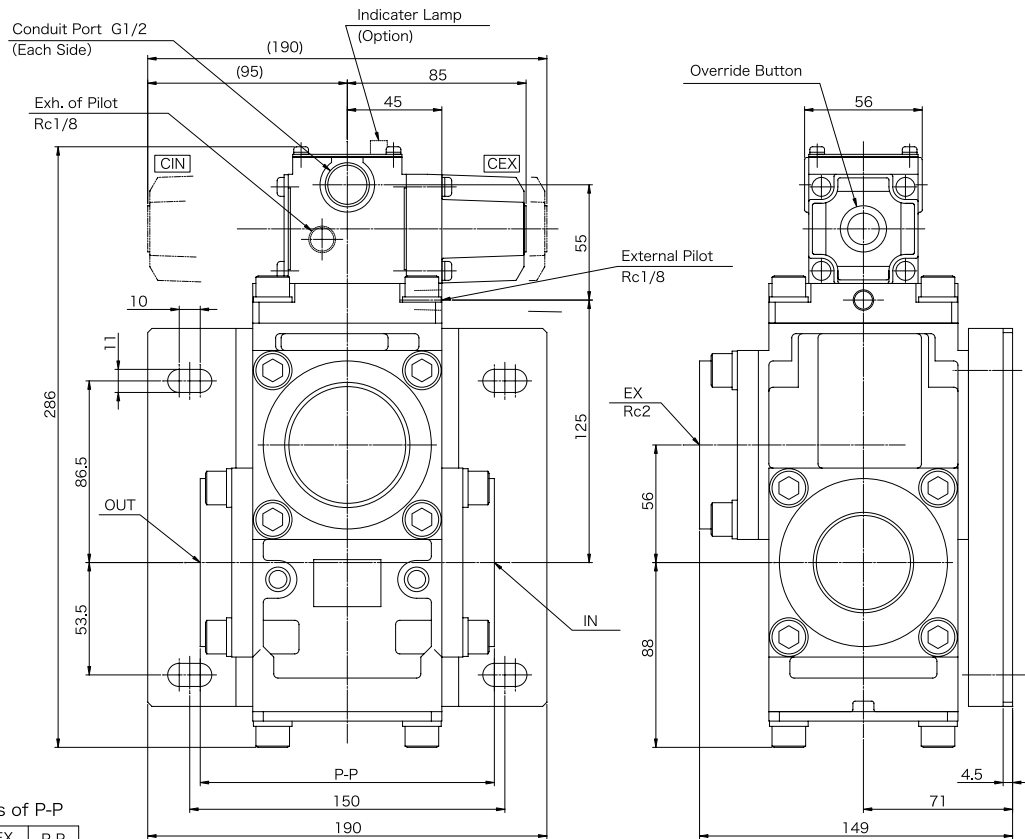
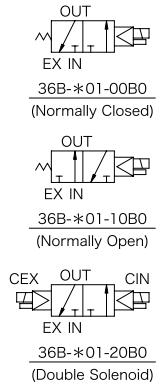
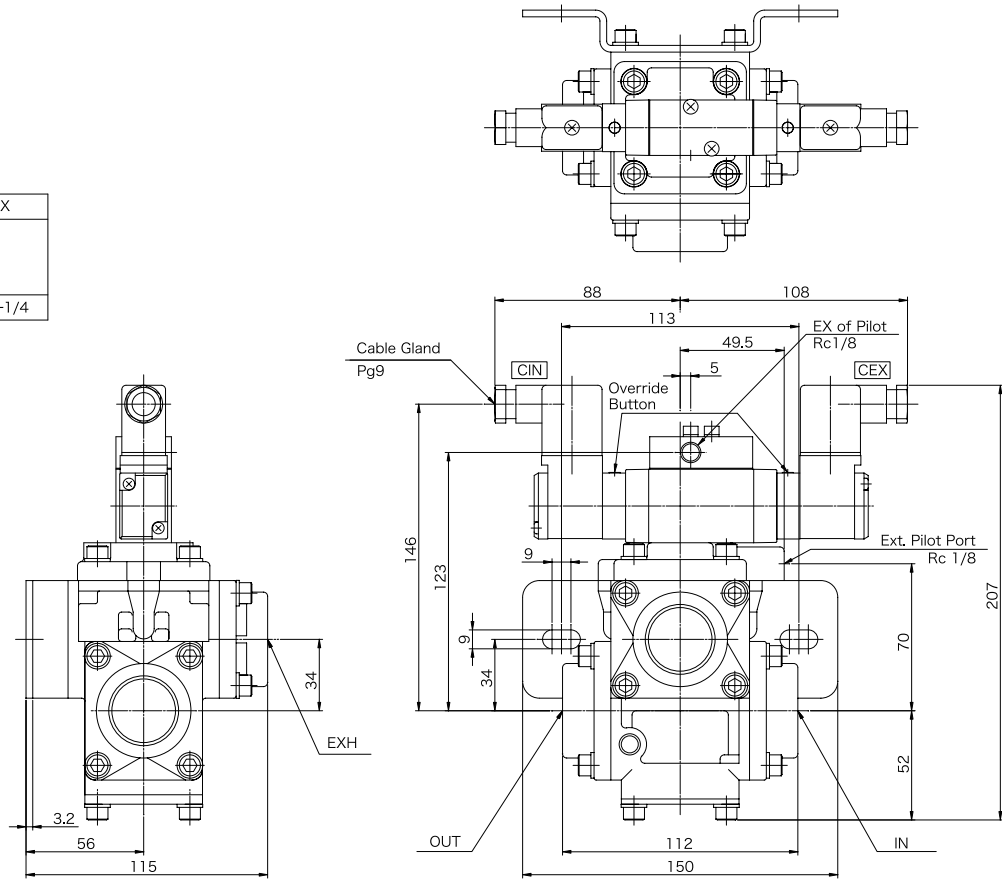

Port Sizes of Each Model & Dims of P-P

Model Numbers	IN & OUT	EX	P-P
36B-A00-※0B0	Rc1-1/4	Rc2	140
36B-B00-※0B0	Rc1-1/2		140
36B-C00-※0B0	Rc2		146

Dimensions in () are for 36B-※00-20B0; Double Sol.

3 PORT SOLENOID VALVE

360 Super Poppet SERIES (Rc¹/₄~Rc2)

FOR VACUUM

IN-LINE TYPE

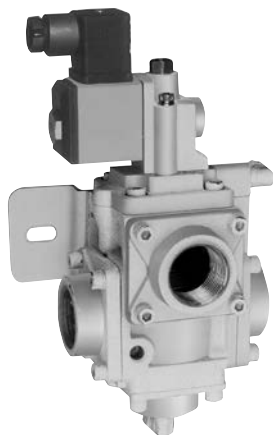

SPECIFICATIONS

FLUID	Vacuum (air)
OPERATING PRESSURE	-0.1 ~ -0.01MPa (External Pilot Supply Type only)
EXTERNAL PILOT SUPPLY PRESSURE	0.2 ~ 0.3MPa
AMBIENT TEMPERATURE	5 ~ 50°C
PROOF PRESSURE	1.6MPa
MANUAL OPERATION	Manual push button/Non-lock type
RATED VOLTAGE	<ul style="list-style-type: none"> • AC-100V 50/60Hz, 110V 60Hz • AC-200V 50/60Hz, 220V 60Hz • DC-24V • DC-100V
VOLTAGE ALLOWANCE	-15 ~ 10%
INSULATION GRADE	Class B

BASIC MODEL NOS. & OTHER SPECIFICATIONS

Port Size		MODEL NUMBER		Effective Area [mm ²] < Cv value >		
IN	OUT	EX	Single Solenoid	Mass [kg]		
			Normally Closed		"1"→"2"	"2"→"3"
Rc ¹ / ₄		Rc ¹ / ₂	363-200-63B0	1.3	42.5< 2.3>	56< 3.0>
Rc ³ / ₈			363-300-63B0		63< 3.4>	85< 4.6>
Rc ¹ / ₂			363-400-63B0		75< 4.1>	100< 5.4>
Rc ¹ / ₂		Rc1	368-400-63B0	2	106< 5.7>	160< 8.6>
Rc ³ / ₄			368-600-63B0		170< 9.2>	236<12.8>
Rc1			368-800-63B0		190<10.2>	250<13.5>
Rc ¹ / ₄		Rc ¹ / ₄	368-A00-63B0	6.2	190<10.2>	250<13.5>
Rc ¹ / ₄		Rc2	36B-A00-63B0		450<24.3>	530<28.6>
Rc ¹ / ₂			36B-B00-63B0		500<27.0>	600<32.4>
Rc2			36B-C00-63B0		530<28.6>	600<32.4>

HOW TO ORDER

36 8 - 8 0 0 - 6 3 B 0 AC-100V

③ ④ ⑦ ⑧ ⑨ ⑩ ⑪

PRODUCT TYPE: 360 SERIES

③ Basic Body Size

3 | 3/8" Basic
8 | 1" Basic
B | 1 1/2" Basic

④ Main Pipe Size

2 | Rc¹/₄
3 | Rc³/₈
4 | Rc¹/₂
6 | Rc³/₄
8 | Rc1
A | Rc¹/₄
B | Rc¹/₂
C | Rc2

*Pipe size should be selected in a certain extent according to the basic body size.
Refer to the BASIC MODEL NOS.

⑦ Function

6 | 2 position Single Solenoid Universal Port

⑧ Pilot Air Supply

3 | External Pilot Air Supply type for Vacuum

⑨ Accessory

B | Manual push button/Non-lock type mounting bracket (Std.)
R | Lock type manual operation button mounting bracket

⑩ Type of Operator

0 | Solenoid (Std.)
2 | Solenoid with indicator and surge killer

⑪ Rated Voltage

AC-100V	AC-100V 50/60Hz, 110V 60Hz
AC-200V	AC-200V 50/60Hz, 220V 60Hz
DC-24V	DC-24V
DC-100V	DC-100V

**When other AC voltage listed above is needed, specify AC voltage and cycle of the solenoid operator.
[EX] 368-800-00B0 AC-110V 50Hz

3 PORT SOLENOID VALVE

360 Super Poppet SERIES (Rc¹/₄~Rc₂)

HIGH-LOW PRESSURE

CHANGE TYPE

Pilot operated poppet valve

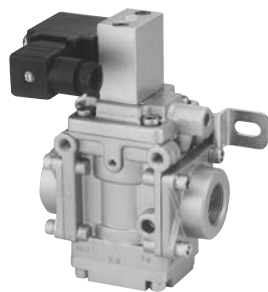

SINGLE SOLENOID

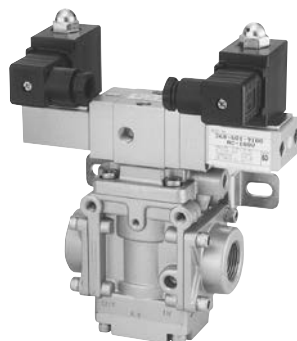

DOUBLE SOLENOID

SPECIFICATIONS

FLUID		Filtered Compressed Air
OPERATING PRESSURE	Pressure Range of Main Valve Side*	High Pressure Side (IN): 0.05 ~ 1.0MPa
		Low Pressure Side (EX): 0 ~ 0.85MPa
Pilot Pressed: Set of P*		P = High Pressure Side (IN) Pressure + 0 ~ 0.2MPa Besides P = Low Pressure Side (EX) Pressure + 0.15MPa
AMBIENT TEMPERATURE		5 ~ 50°C
PROOF PRESSURE		1.6MPa
LUBRICANTS		ISO VG32 turbine oil, or equivalent oil is recommended. (Non-Lubrication is also available)
MANUAL OPERATION		Manual push button / Non-lock type
RATED VOLTAGE		<ul style="list-style-type: none"> • AC-100V 50/60Hz, 110V 60Hz • AC-200V 50/60Hz, 220V 60Hz • DC-24V • DC-100V
VOLTAGE ALLOWANCE		-15 ~ 10%
INSULATION GRADE		Class B

*1 Higher pressure side = (IN PORT), Lower pressure side = (EX PORT)

*2 Pilot air should be lower than 1.0MPa

*3 Operating pressure range of 36B series (Rc¹/₄ ~ Rc₂) is 0.2 ~ 1.0MPa.

BASIC MODEL NOS. & OTHERS

Port Size	MODEL NUMBER						Effective Area [mm ²] (Cv value)	
	2-Position, Single Solenoid			2-Position, Double Solenoid				
	Normally Close	Response Time* (msec)	Mass (kg)		Response Time* (msec)	Mass (kg)		
							IN-OUT	OUT-EX
Rc ¹ / ₄	363-201-81B0	max. 40ms	1.1	363-201-91B0	max. 40ms	1.4	44< 2.4>	42< 2.3>
Rc ³ / ₈	363-301-81B0			363-301-91B0			53< 2.9>	50< 2.7>
Rc ¹ / ₂	363-401-81B0			363-401-91B0			55< 3.0>	60< 3.3>
Rc ¹ / ₂	368-401-81B0	max. 40ms	1.8	368-401-91B0	max. 40ms	2.0	125< 6.8>	135< 7.3>
Rc ³ / ₄	368-601-81B0			368-601-91B0			180< 9.8>	170< 9.2>
Rc1	368-801-81B0			368-801-91B0			195<10.6>	180< 9.8>
Rc1 ¹ / ₄	368-A01-81B0			368-A01-91B0			200<10.8>	180< 9.8>
Rc1 ¹ / ₄	36B-A00-81B0			36B-A00-91B0			410<22.2>	386<20.9>
Rc1 ¹ / ₂	36B-B00-81B0	max. 40ms	6.4	36B-B00-91B0	max. 40ms	7.0	450<24.4>	407<22.1>
Rc2	36B-C00-81B0			36B-C00-91B0			480<26.0>	423<22.9>

Response times (typical) are values at 0.5MPa supply pressure.

On valve working after long suspension, above values might be exceeded.

HOW TO ORDER

36 8 - 8 0 1 - 8 1 B 0 AC-100V

③ ④ ⑦ ⑧ ⑨ ⑩ ⑪

PRODUCT TYPE: 360 SERIES

③ Basic Body Size

3 3/8" Basic
8 1" Basic
B 1 1/2" Basic

④ Main Pipe Size

2 Rc¹/₄
3 Rc³/₈
4 Rc¹/₂
6 Rc³/₄
8 Rc1
A Rc1¹/₄
B Rc1¹/₂
C Rc2

⑦ Function

8 Single solenoid
Dual supply
9 Double solenoid
Dual supply

⑧ Pilot Air Supply

1 External Pilot Air Supply

⑨ Accessory

B Manual push button / Non-lock type mounting bracket (Std.)
R Lock type manual operation button mounting bracket

⑩ Type of Operator

0 Solenoid (Std.)
2 Solenoid with indicator and surge killer

⑪ Rated Voltage

AC-100V	AC-100V 50/60Hz, 110V 60Hz
AC-200V	AC-200V 50/60Hz, 220V 60Hz
DC-24V	DC-24V
DC-100V	DC-100V

DIMENSIONS —mm—

360 Series, 3-Port High/Low Pressure Change Valve

310-087-1

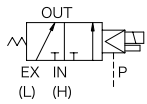

363-※01-81B0
(High-Low Press. Change)

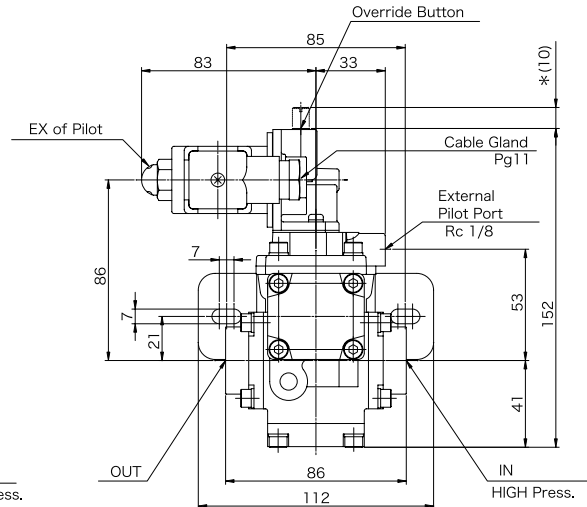
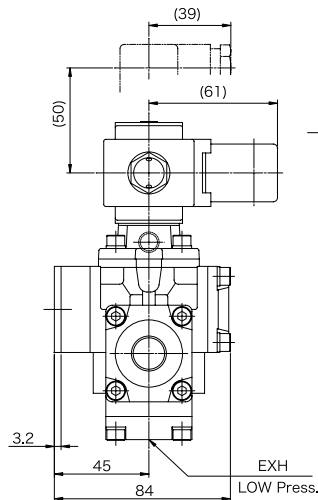

* (10) is dimension of a lockable override (option)

Port Sizes of Each Model

Model Numbers	IN, OUT & EX
363-201-81B0	Rc1/4
363-301-81B0	Rc3/8
363-401-81B0	Rc1/2

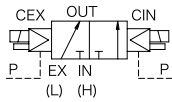

363-※01-91B0
(High-Low Press. Change)

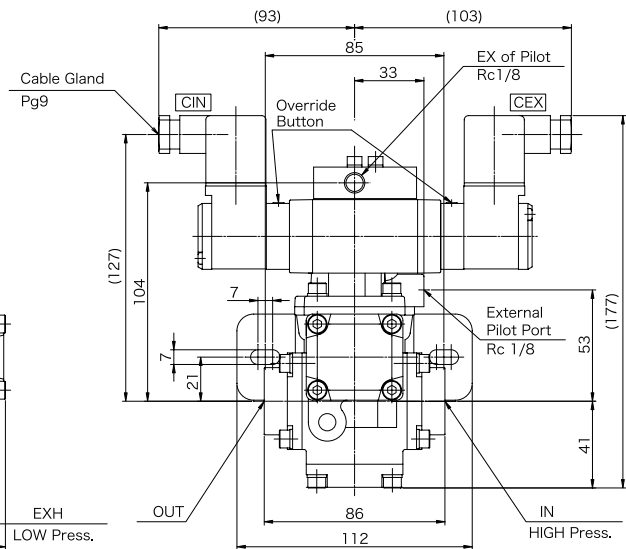
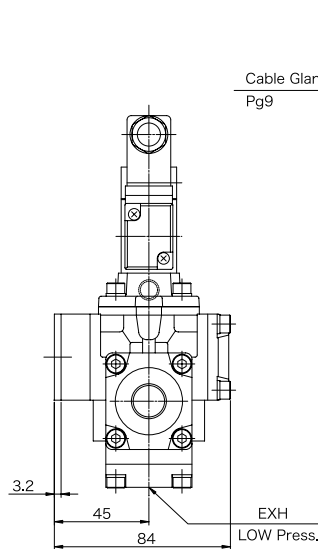

Port Sizes of Each Model

Model Numbers	IN, OUT & EX
363-201-91B0	Rc1/4
363-301-91B0	Rc3/8
363-401-91B0	Rc1/2

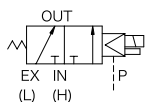

368-※01-81B0
(High-Low Press. Change)

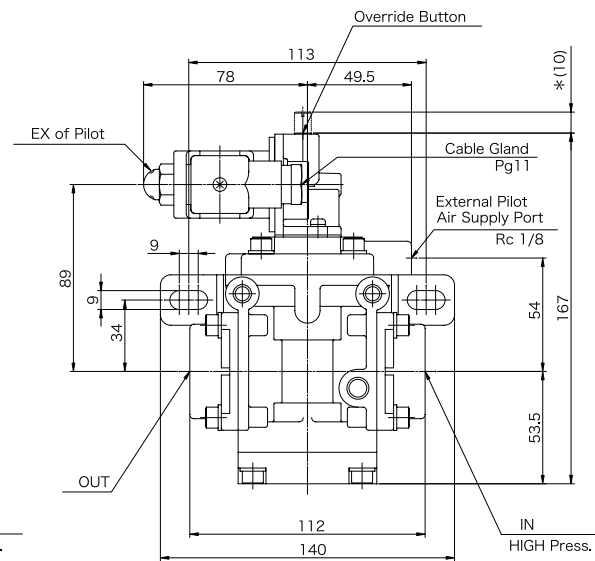
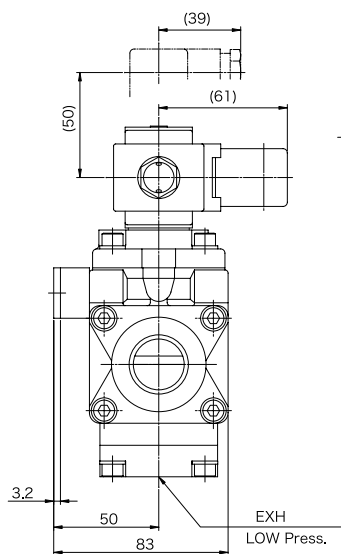

* (10) is dimension of a lockable override (option)

Port Sizes of Each Model

Model Numbers	IN, OUT & EX
368-401-81B0	Rc1/2
368-601-81B0	Rc3/4
368-801-81B0	Rc1
368-A01-81B0	Rc1-1/4

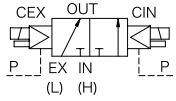

368-※01-91B0
(High-Low Press. Change)

Port Sizes of Each Model

Model Numbers	IN, OUT & EX
368-401-91B0	Rc1/2
368-601-91B0	Rc3/4
368-801-91B0	Rc1
368-A01-91B0	Rc1-1/4

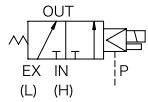
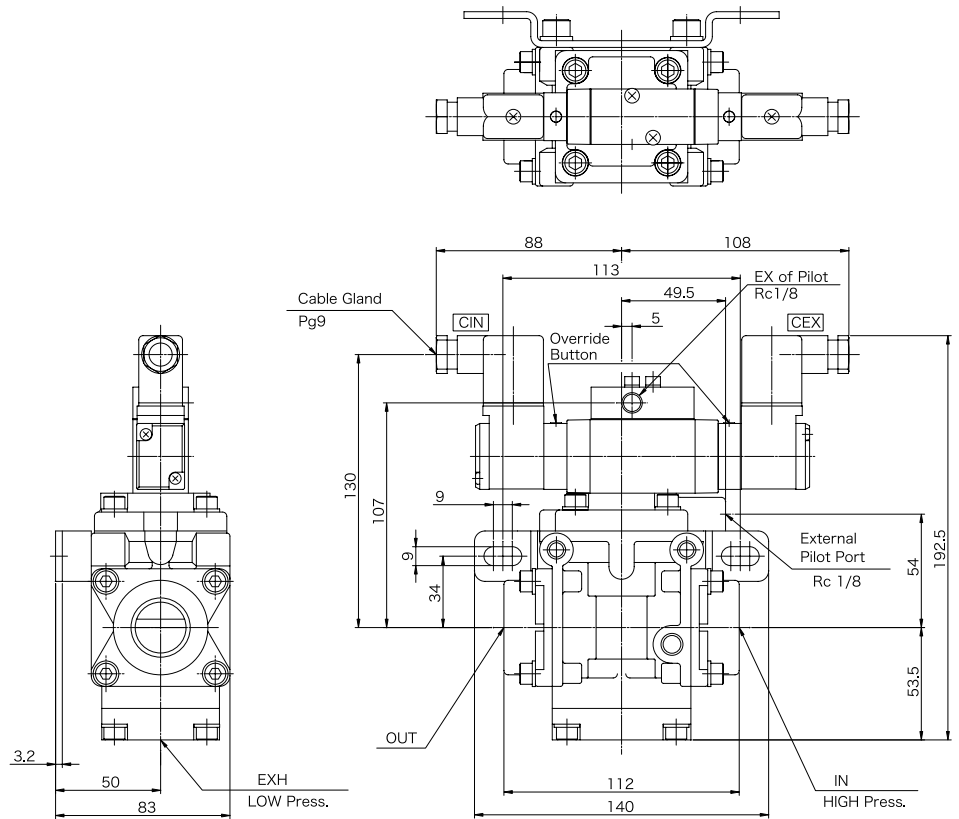

368-※01-81B0
(High-Low Press. Change)

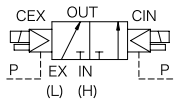

368-※01-91B0
(High-Low Press. Change)

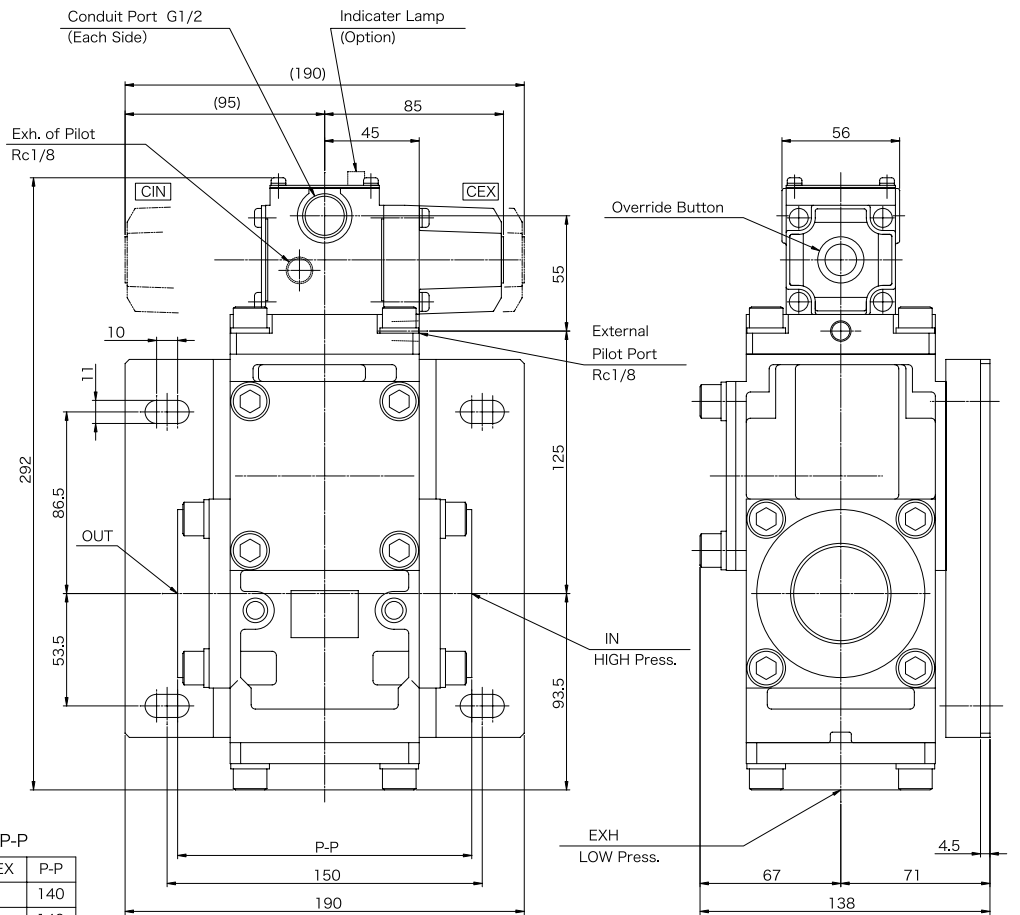

Port Sizes of Each Model, Dims of P-P

Model Numbers	IN, OUT & EX	P-P
36B-A00-81B0/91B0	Rc1-1/4	140
36B-B00-81B0/91B0	Rc1-1/2	140
36B-C00-81B0/91B0	Rc2	146

Dimensions in () are for 36B-※00-91B0; Double Sol.

3 PORT SOLENOID VALV

392 SERIES (Rc^{1/4}, Rc^{3/8})

FOR COMPRESSED AIR & VACUUM

Directly operated poppet valve



SPECIFICATIONS

FLUID	Filtered Compressed Air	Vacuum
OPERATING PRESSURE	0 ~ 0.7MPa	-0.1 ~ 0MPa
AMBIENT TEMPERATURE	5 ~ 50°C	
LUBRICANTS	Can use without lubrication	
MANUAL OPERATION	Manual push button/Non-lock type	
RATED VOLTAGE	<ul style="list-style-type: none"> •AC-100V 50/60Hz, 110V 60Hz •AC-200V 50/60Hz, 220V 60Hz •DC-24V 	
VOLTAGE ALLOWANCE	-15 ~ 10%	
INSULATION GRADE	Class B	

BASIC MODEL NOS. & OTHERS

Port Size A.B.O	MODEL NUMBER				Effective Area [mm ²] < Cv value >	Mass [kg]
	Compressed Air		Vacuum			
	DIN Type Connector	DIN Type Connector (with pilot lamp)	DIN Type Connector	DIN Type Connector (with pilot lamp)		
Rc ^{1/4}	392-200-60B1	392-200-60B4	392-200-02B1	392-200-02B4	11 < 0.6 >	0.4
Rc ^{3/8}	392-300-60B1	392-300-60B4	392-300-02B1	392-300-02B4		

HOW TO ORDER (Single Valve Unit)

392-200-60B1

④ ⑦ ⑨⑩ ⑪

PRODUCT TYPE: 392 SERIES

④ Port Size
2 Rc^{1/4}
3 Rc^{3/8}

⑦ Function
60 Compressed Air use, Universal porting
02 Vacuum use, 2 position normally closed type.

⑨ Accessory
B with Bracket (Std.)

⑩ Electrical Connection
1 DIN type connector
4 DIN type connector with pilot lamp

⑪ Rated Voltage
AC-100V AC-100V 50/60Hz, 110V 60Hz
AC-200V AC-200V 50/60Hz, 220V 60Hz
DC-24V DC-24V
DC-100V DC-100V

HOW TO ORDER (Manifold)

392-260-6001

⑤ ⑩

⑤ No. of valves composing manifold
2 ~ 6 available

⑩ Electrical Connection
1 DIN type connector
4 DIN type connector with pilot lamp

Following usages are available by selecting use port

Universal Port Configuration provides 6 usages by choosing air supply port.		
3-port Normally Closed	2-port Normally Closed	Selector
3-port Normally Open	2-port Normally Open	Diverter

392 Single Valve Unit

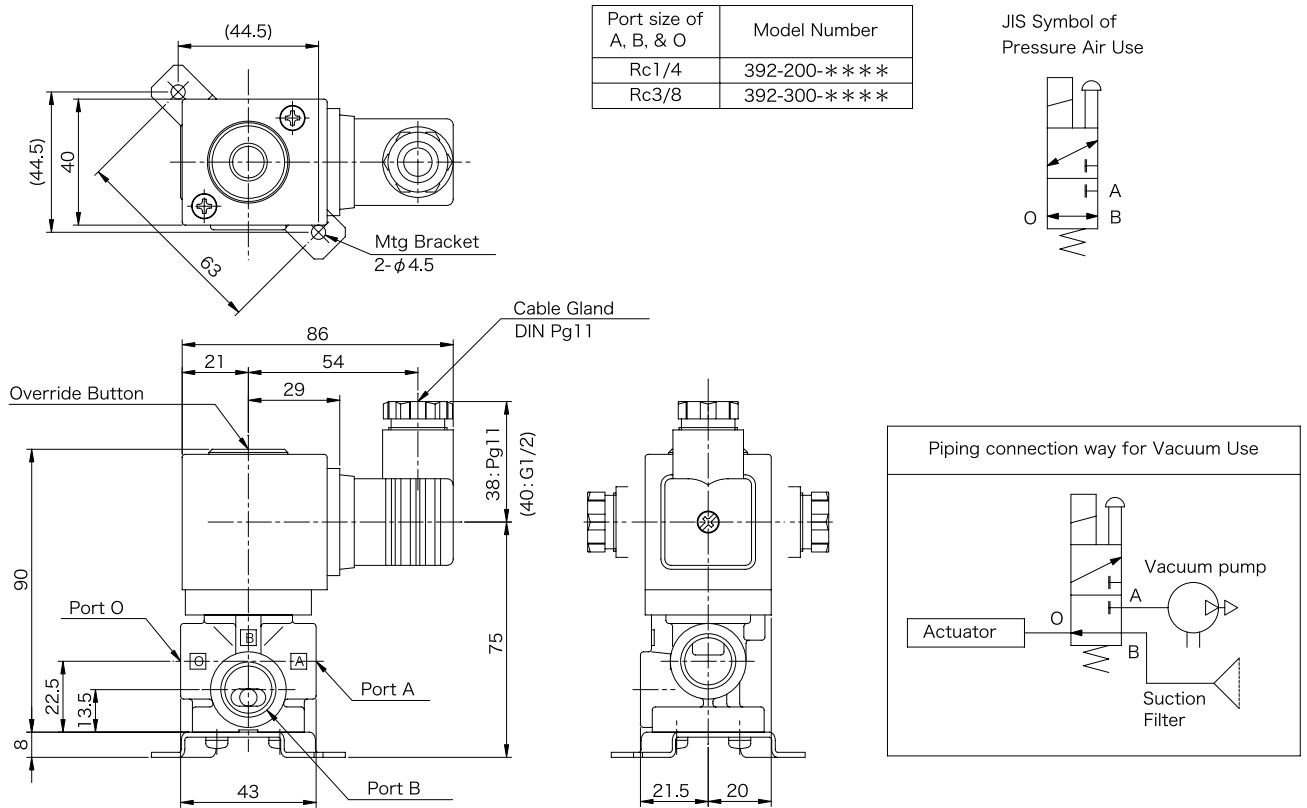

392 Manifold Type

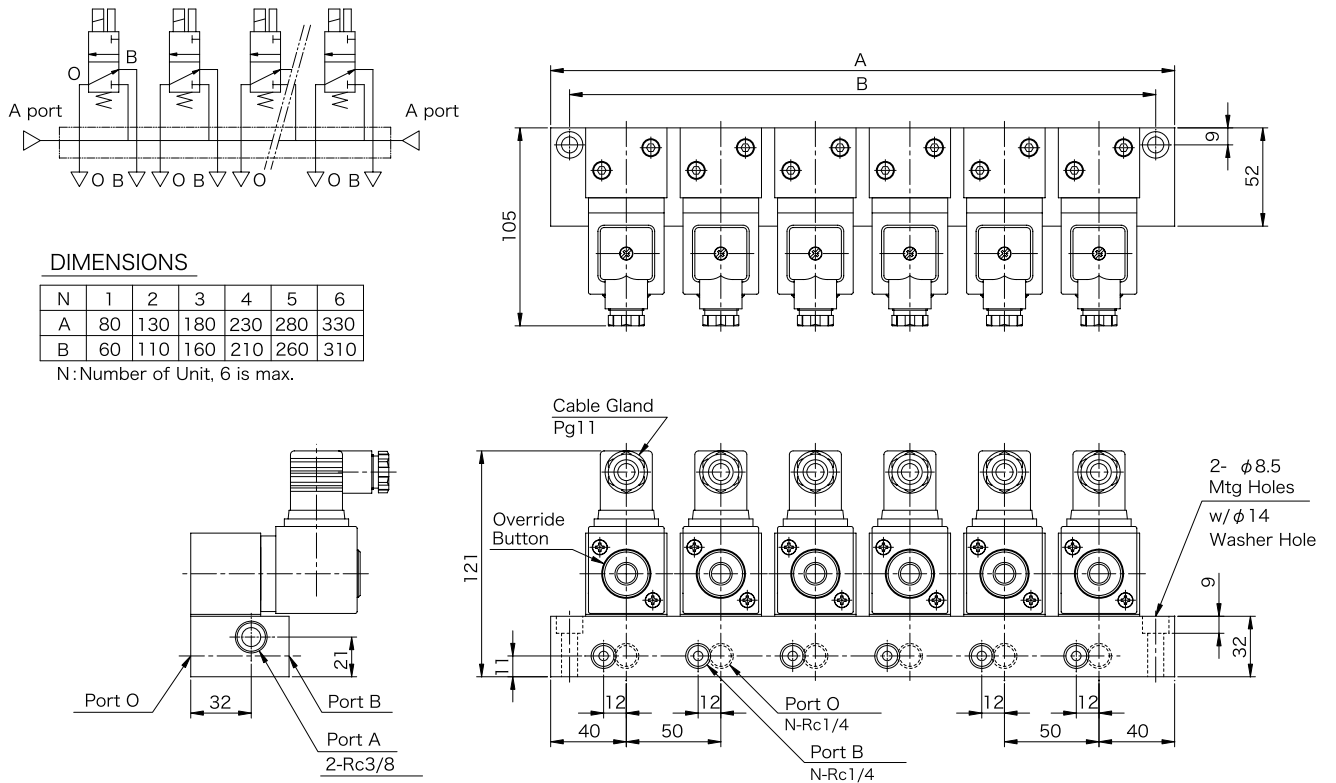

Model Nos. ordering single valve unit of the manifold.
 392-2F0-6001 xxV
 392-2F0-6004 xxV . . . w/pilot lamp, & surge killer

This drawing is made with 6 units manifold.

(310-073, modified by x0.6 for fitting indication)

3 PORT SOLENOID VALVE DUAL VALVE FOR PRESS MACHINE

354 SERIES (Rc³/₈~Rc1)

MVS-3500YCG/YCL/YCK SERIES (Rc³/₈~Rc1¹/₂)



354

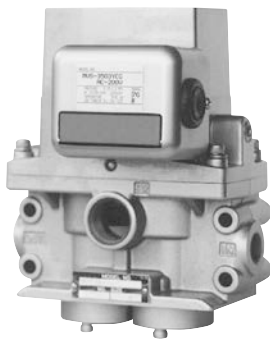

MVS-3500YCG

SPECIFICATIONS

	354 Series	MVS-3500Y Series
FLUID	Filtered Compressed Air	
OPERATING PRESSURE	0.20 ~ 0.85MPa (Internal Pilot)	0.15 ~ 1.0MPa (Internal Pilot)
	0.05 ~ 0.85MPa (External Pilot)	0.05 ~ 1.0MPa (External Pilot)
AMBIENT TEMPERATURE	5 ~ 50°C	
LUBRICANTS	ISO VG32 turbine oil, or equivalent oil is recommended.	
MANUAL OPERATION	Manual push button/Non-lock type	
RATED VOLTAGE	<ul style="list-style-type: none"> • AC-100V 50/60Hz, 110V 60Hz • AC-200V 50/60Hz, 220V 60Hz • DC-24V 	
VOLTAGE ALLOWANCE	±10%	-15 ~ 10%
INSULATION GRADE	Class B	

Basic Model No. & OTHERS

Type of Valve	Pipe Sizes		Model Numbers	Effective Area [mm ² , typical]		Mass [kg]
	1, 2 Port	3 Port		1→2	2→3	
Cross flow	Rc ³ / ₈	Rc ³ / ₄	354-300-C000	65	105	2.5
	Rc ¹ / ₂		354-400-C000	65	140	
	Rc ³ / ₄		354-600-C000			
	Rc ³ / ₄	Rc1 ¹ / ₄	358-600-C000	110	310	4.0
	Rc1		358-800-C000	110	360	
Parallel flow	Rc ³ / ₈	Rc ³ / ₄	354-300-P000	29	105	2.5
	Rc ¹ / ₂		354-400-P000	29	140	
	Rc ³ / ₄		354-600-P000			
	Rc ³ / ₄	Rc1 ¹ / ₄	358-600-P000	63	310	3.2
	Rc1		358-800-P000	63	360	

Pipe Size	MODEL NUMBER					Effective Area [mm ²] < Cv value >	
	MONITORLESS	Mass [kg]	LIMIT SWITCH TYPE MONITOR	PROXIMITY SWITCH TYPE MONITOR	Mass [kg]	IN-OUT	OUT-EX
Rc ³ / ₈	MVS-3503YCG	3.2	MVS-3503YCL	MVS-3503YCK	3.5	25 < 1.4 >	105 < 5.7 >
Rc ¹ / ₂	MVS-3504YCG		MVS-3504YCL	MVS-3504YCK		29 < 1.6 >	172 < 9.3 >
Rc ³ / ₄	MVS-3506JYCG		MVS-3506JYCL	MVS-3506JYCK		29 < 1.6 >	180 < 9.7 >
Rc ³ / ₄	MVS-3506YCG	3.5	MVS-3506YCL	MVS-3506YCK	3.9	74 < 4.0 >	335 < 18.1 >
Rc1	MVS-3510YCG		MVS-3510YCL	MVS-3510YCK		74 < 4.0 >	395 < 21.4 >
Rc1 ¹ / ₄	MVS-3512YCG	7.5	MVS-3512YCL	MVS-3512YCK	8.8	190 < 10.3 >	960 < 51.9 >
Rc1 ¹ / ₂	MVS-3514YCG		MVS-3514YCL	MVS-3514YCK		190 < 10.3 >	1140 < 61.6 >

JIS Symbol of 354/358 Series DUAL VALVE

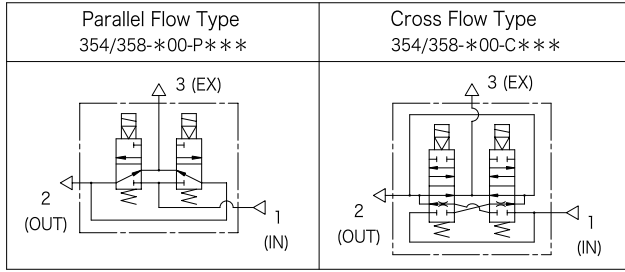

354-300/400/600-*000

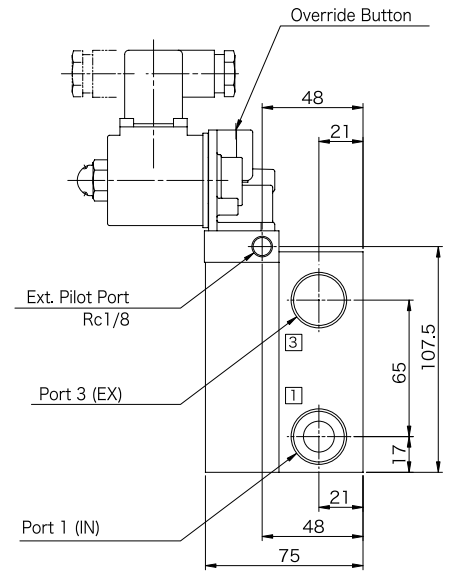
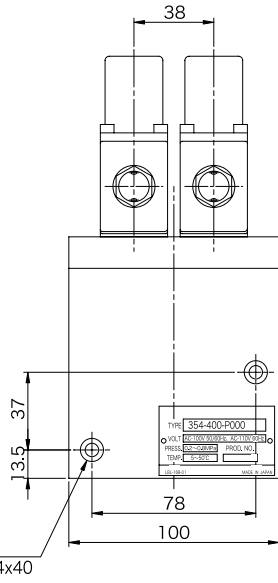
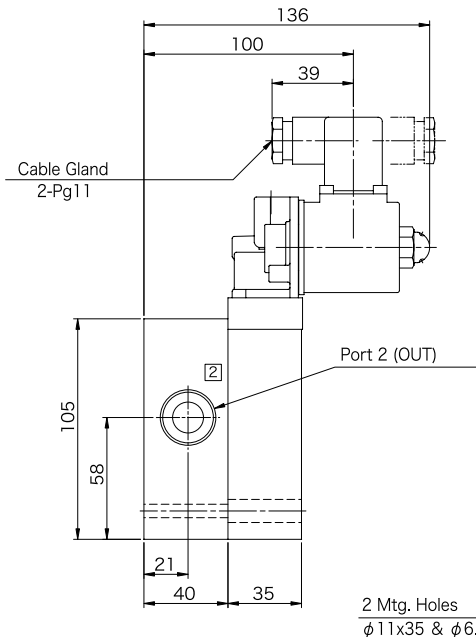

Port sizes of Each Model

Model Nos.	Port 1, 2	Port 3
354-300-P****	Rc3/8	Rc3/4
354-300-C****		
354-400-P****	Rc1/2	
354-400-C****		
354-600-P****	Rc3/4	
354-600-C****		

358-600/800-*000

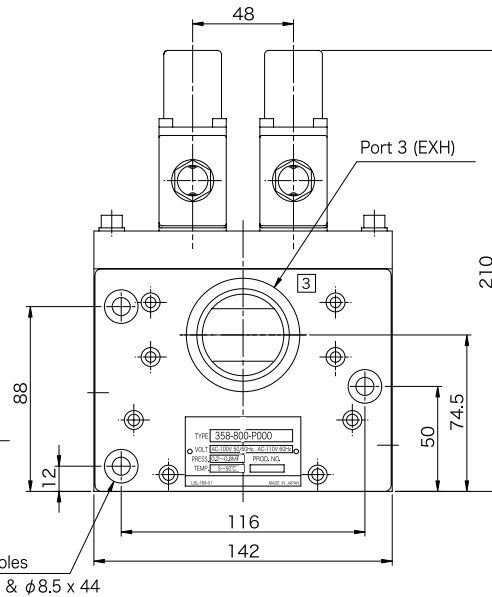
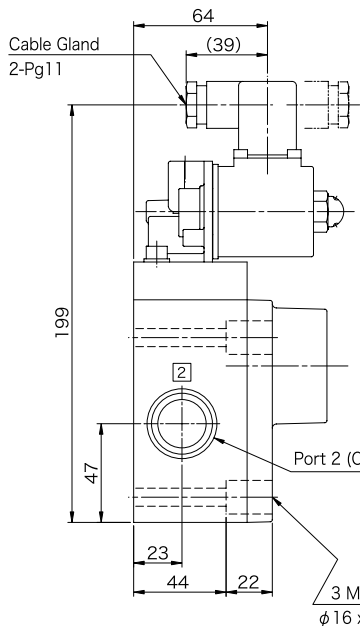

Port sizes of Each Model

Model Nos.	Port 1, 2	Port 3
358-600-P****	Rc3/4	Rc1-1/4
358-600-C****		
358-800-P****	Rc1	
358-800-C****		

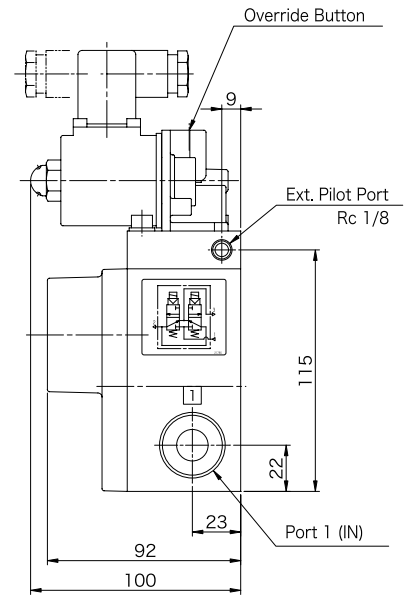

(By dwg H-7704-07a, 3J-5411a)

DIMENSIONS

—mm—

3500YCG Series Dual Valve

MVS-3503YCG
MVS-3504YCG

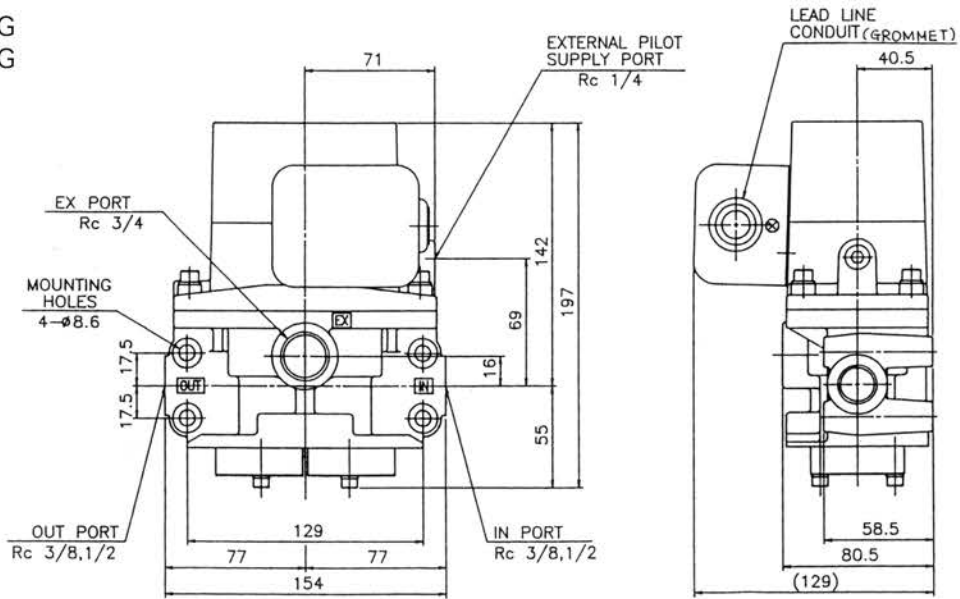

MVS-3506YCG
MVS-3510YCG

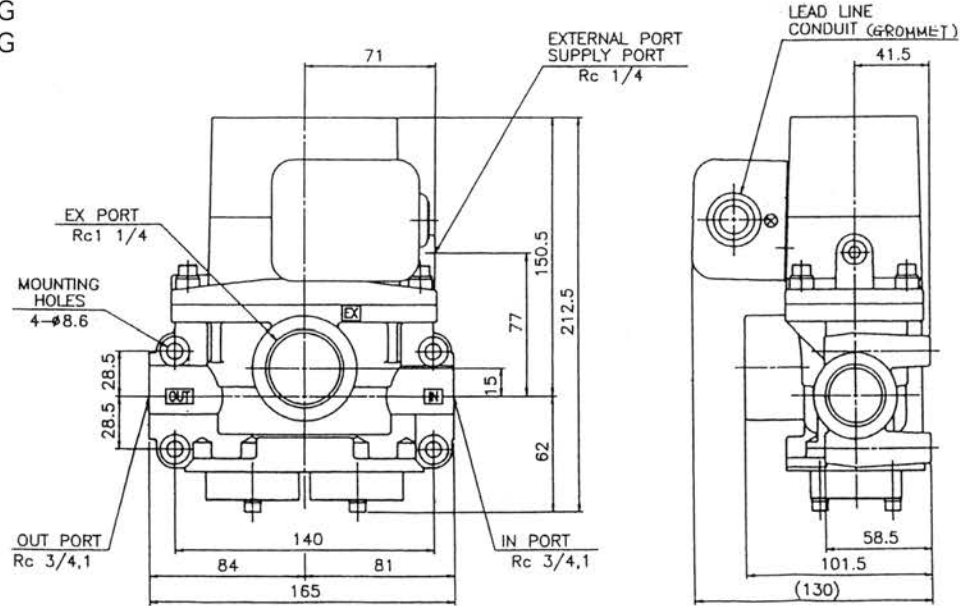

MVS-3512YCG
MVS-3514YCG

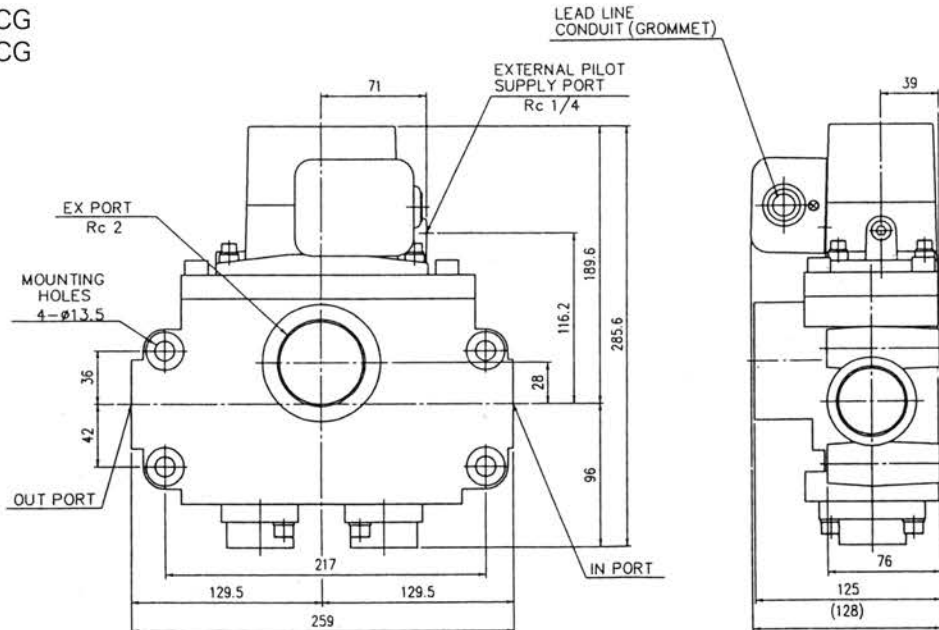

DIMENSIONS

-mm-

3500YCL/YCK Series Dual Valve

MVS-3503, 04YCL/YCK
MVS-3506JYCL/JYCK

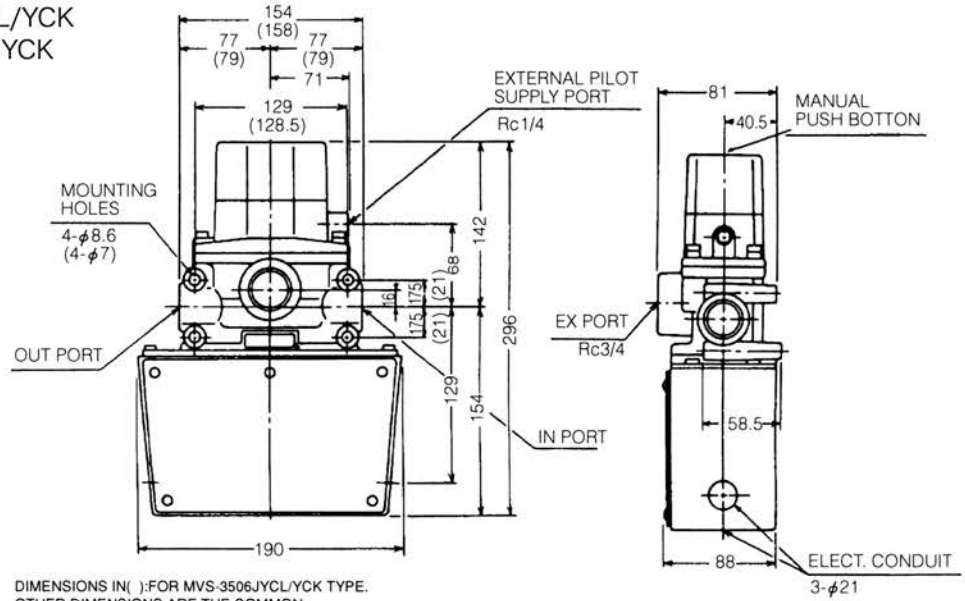

MVS-3506, 10YCL/YCK

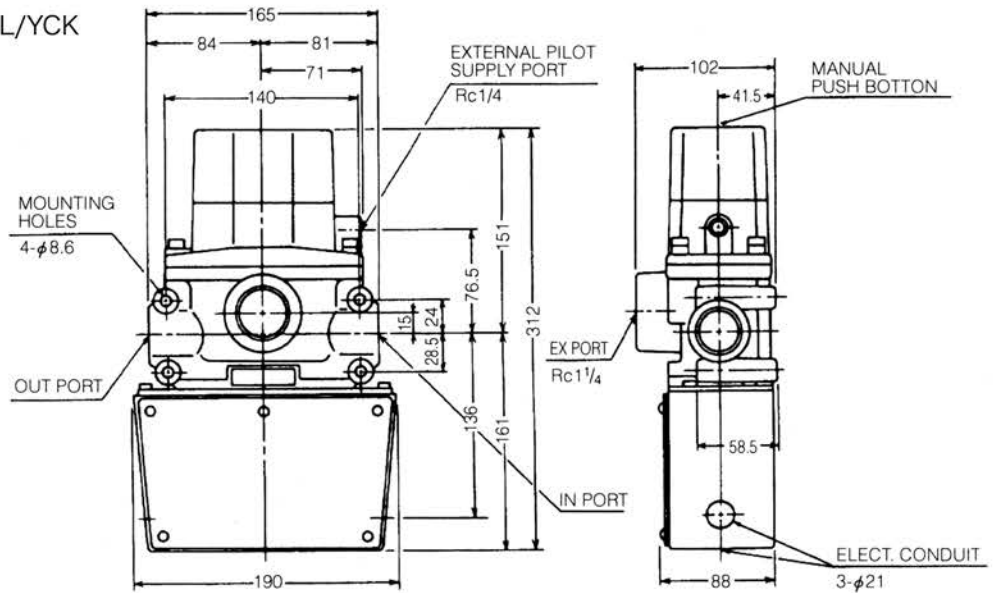

MVS-3512, 14YCL/YCK

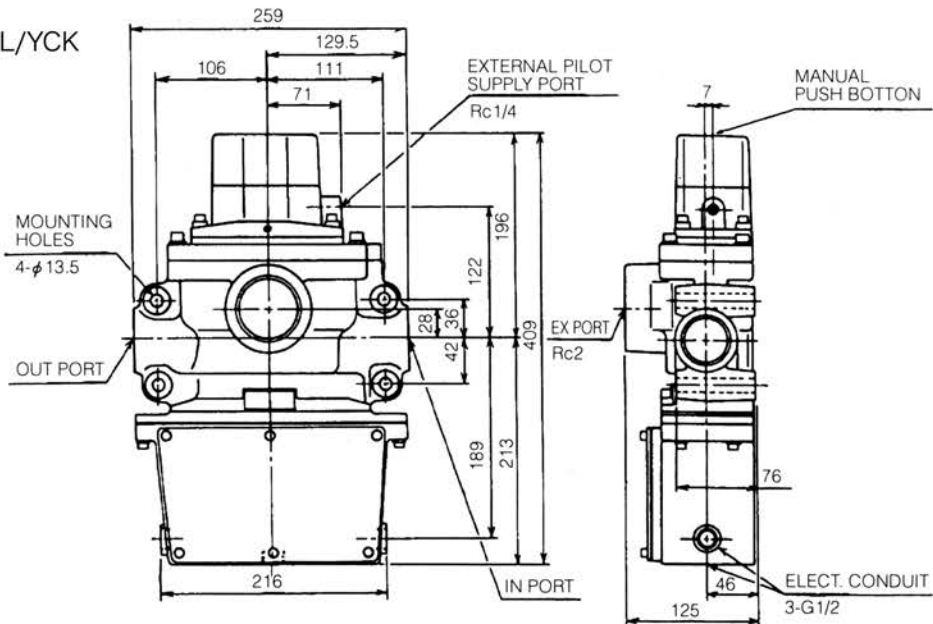

2 PORT SOLENOID VALVE

MVS-2200Y SERIES (Rc¹/₄~Rc¹/₂)
MVS-2300Y SERIES (Rc¹/₂~Rc1¹/₄)

FOR COMPRESSED AIR
FOR LIQUID & VACUUM
IN-LINE TYPE

Pilot operated
poppet valve



MVS-2200Y



MVS-2300Y

SPECIFICATIONS

FLUID	Compressed Air	Liquid*	Vacuum
OPERATING PRESSURE RANGE	0.02 ~ 0.7MPa	0.15 ~ 0.7MPa	-0.08 ~ 0MPa
AMBIENT TEMPERATURE	5 ~ 50°C		
LUBRICANT	Required		
MANUAL OPERATION	Nil		
RATED VOLTAGE	<ul style="list-style-type: none"> AC-100V 50/60Hz, 110V 60Hz AC-200V 50/60Hz, 220V 60Hz DC-24V • DC-100V 		
VOLTAGE ALLOWANCE	-15 ~ 10%		
INSULATION GRADE	Class B		

* Use non-corrosive and low viscosity liquid.

BASIC MODEL NOS. & OTHER SPECIFICATIONS

Pipe Size	MODEL NUMBER		Mass [kg]	Effective Area [mm ²] < Cv value >
	Single Solenoid Normally Closed			
	Compressed Air/Liquid	Vacuum		
Rc ¹ / ₄	MVS-2202Y	MVS-2202YV	0.5	35 < 1.9 >
Rc ³ / ₈	MVS-2203Y	MVS-2203YV		40 < 2.2 >
Rc ¹ / ₂	MVS-2204JY	MVS-2204JYV		

Pipe Size	MODEL NUMBER		Mass [kg]	Effective Area [mm ²] < Cv value >
	Single Solenoid Normally Closed			
	Compressed Air/Liquid	Vacuum		
Rc ¹ / ₂	MVS-2304Y	MVS-2304YV	1.5	110 < 5.9 >
Rc ³ / ₄	MVS-2306Y	MVS-2306YV		170 < 9.2 >
Rc1	MVS-2310Y	MVS-2310YV		240 < 13.0 >
Rc1 ¹ / ₄	MVS-2312JY	MVS-2312JYV		350 < 18.9 >

HOW TO ORDER

MVS - 22 Y

① ② ③ ④ ⑤ ⑥ ⑦

SINGLE SOLENOID

PRODUCT TYPE: MVS-2200Y SERIES

MVS - 23 Y

① ② ③ ④ ⑤ ⑥ ⑦

SINGLE SOLENOID

PRODUCT TYPE: MVS-2300Y SERIES

① Pipe Size (MVS-2200Y)

02 | Rc¹/₄
03 | Rc³/₈
04J | Rc¹/₂ (over ported)

① Pipe Size (MVS-2300Y)

04 | Rc¹/₂
06 | Rc³/₄
10 | Rc1
12J | Rc1¹/₄ (over ported)

② Type of Solenoid

NIL | For AC use
H | For DC use

③ Purpose

NIL | Compressed Air & Liquid use
V | Vacuum use

④ Accessory

NIL | Without accessory
S | DIN lamp terminal w/surge killer

⑤ Electrical Connection

NIL | Pg11 DIN terminal connection

⑥ Bracket

NIL | Without bracket
B | With bracket

⑦ Rated Voltage

AC-100V | AC-100V 50/60Hz, 110V 60Hz
AC-200V | AC-200V 50/60Hz, 220V 60Hz
DC-24V | DC-24V

MVS-2202Y(V)~04JY(V)

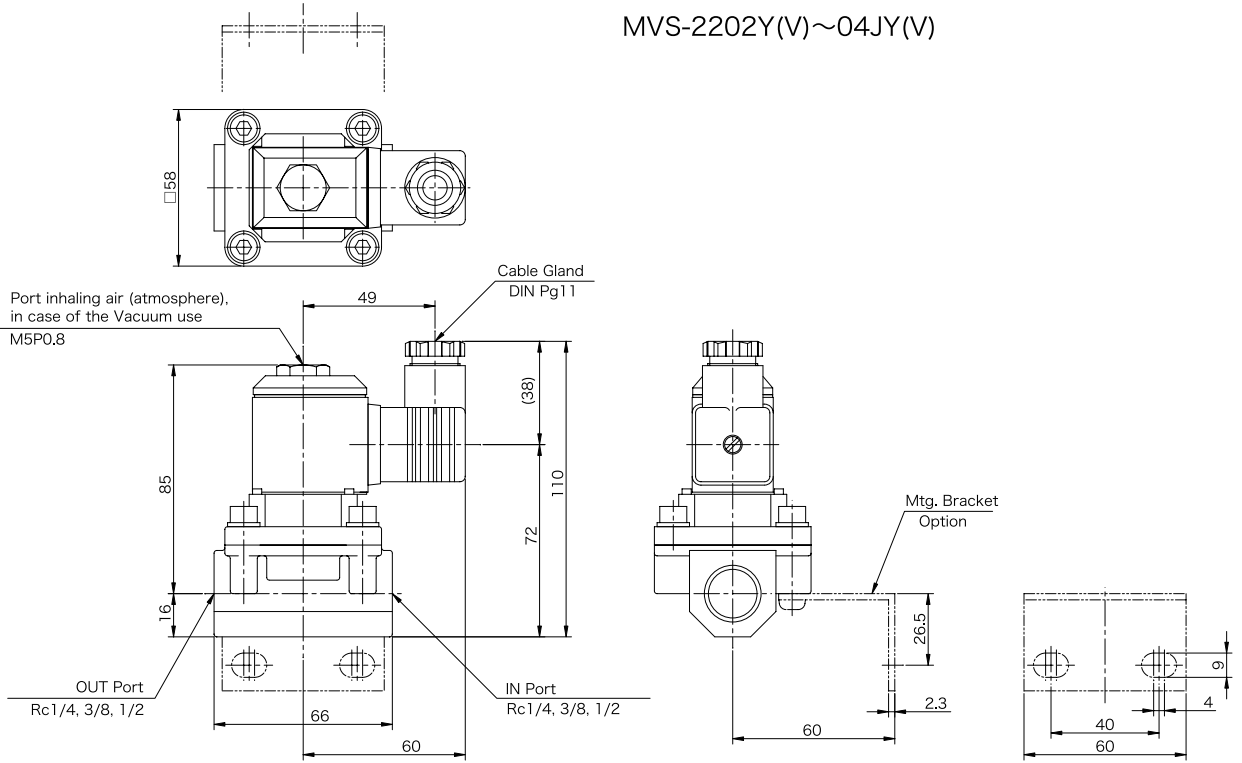

MVS-2304Y(V)~12JY(V)

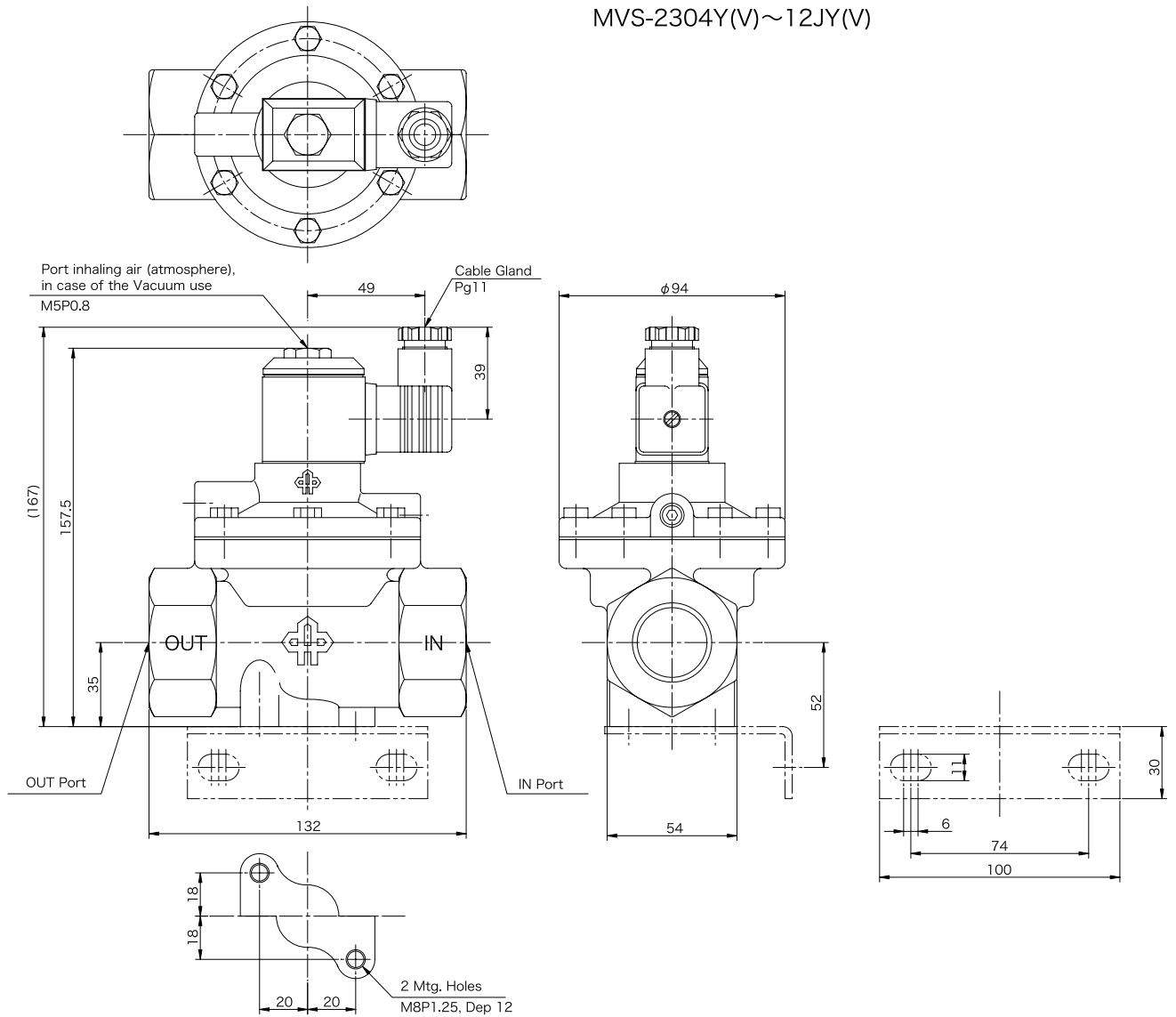

2 PORT SOLENOID VALVE

260 Super Poppet SERIES (Rc¹/₄~Rc2)

IN-LINE TYPE

Pilot operated poppet valve

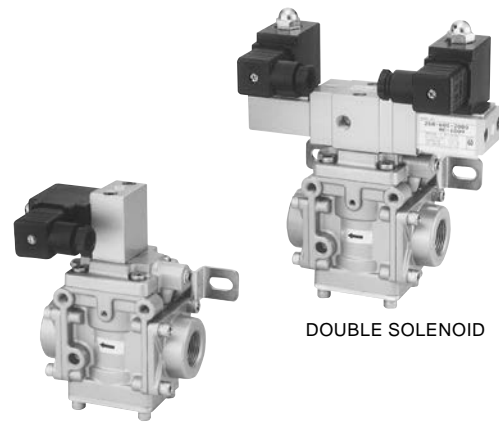

SINGLE SOLENOID

DOUBLE SOLENOID

SPECIFICATIONS

FLUID	Filtered Compressed Air
OPERATING PRESSURE	0.15 ~ 1.0MPa (Internal Pilot Supply type)
	0.05 ~ 1.0MPa (External Pilot Supply type)
AMBIENT TEMPERATURE	5 ~ 50°C
PROOF PRESSURE	1.6MPa
LUBRICANTS	ISO VG32 turbine oil, or equivalent oil is recommended.
MANUAL OPERATION	Manual push button/Non-lock type
RATED VOLTAGE	<ul style="list-style-type: none"> • AC-100V 50/60Hz, 110V 60Hz • AC-200V 50/60Hz, 220V 60Hz • DC-24V • DC-100V
VOLTAGE ALLOWANCE	-15 ~ 10%
INSULATION GRADE	Class B

BASIC MODEL NOS. & OTHERS

Pipe Size	MODEL NUMBER					Effective Area [mm ²] < Cv value >	
	Single Solenoid		Mass [kg]	Double Solenoid	Mass [kg]	Normally Closed & Double Solenoid	Normally Open
	Normally Closed	Normally Open					
	IN-OUT						
Rc ¹ / ₄	263-201-00B0	263-201-10B0	1.1	263-201-20B0	1.2	40 < 2.2 >	40 < 2.2 >
Rc ³ / ₈	263-301-00B0	263-301-10B0		263-301-20B0		58 < 3.1 >	53 < 2.9 >
Rc ¹ / ₂	263-401-00B0	263-401-10B0		263-401-20B0		71 < 3.8 >	63 < 3.4 >
Rc ¹ / ₂	268-401-00B0	268-401-10B0	1.8	268-401-20B0	1.9	106 < 5.7 >	112 < 6.1 >
Rc ³ / ₄	268-601-00B0	268-601-10B0		268-601-20B0		170 < 9.2 >	170 < 9.1 >
Rc1	268-801-00B0	268-801-10B0		268-801-20B0		190 < 10.2 >	190 < 10.2 >
Rc1 ¹ / ₄	268-A01-00B0	268-A01-10B0		268-A01-20B0		190 < 10.2 >	190 < 10.2 >
Rc1 ¹ / ₄	26B-A00-00B0	26B-A00-10B0	6.2	26B-A00-20B0	6.8	450 < 24.3 >	480 < 25.9 >
Rc1 ¹ / ₂	26B-B00-00B0	26B-B00-10B0		26B-B00-20B0		510 < 27.5 >	550 < 29.7 >
Rc2	26B-C00-00B0	26B-C00-10B0		26B-C00-20B0		570 < 30.8 >	600 < 34.4 >

HOW TO ORDER

268-80※-00B0 AC-100V

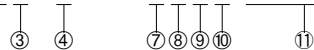

PRODUCT TYPE: 260 SERIES

③ Basic Body Size

- 3 3/8" Basic
- 8 1" Basic
- B 1 1/2" Basic

④ Main Pipe Size

- 2 Rc¹/₄
- 3 Rc³/₈
- 4 Rc¹/₂
- 6 Rc³/₄
- 8 Rc1
- A Rc1¹/₄
- B Rc1¹/₂
- C Rc2

⑦ Function

- 0 Single solenoid, Normally closed
- 1 Single solenoid, Normally open
- 2 Double solenoid

⑧ Pilot Air Supply

- 0 Internal Pilot Air Supply (Std.)
- 1 External Pilot Air Supply

⑨ Accessory

- B Manual push button/Non-lock type mounting bracket
- R Lock type manual operation button mounting bracket

⑩ Type of Operator

- 0 Solenoid (Std.)
- 2 Solenoid with indicator and surge killer

⑪ Rated Voltage

- | | |
|---------|----------------------------|
| AC-100V | AC-100V 50/60Hz, 110V 60Hz |
| AC-200V | AC-200V 50/60Hz, 220V 60Hz |
| DC-24V | DC-24V |
| DC-100V | DC-100V |

DIMENSIONS

-mm-

260 Series, 2-Port Solenoid Valve, 2-Position

310-088-1

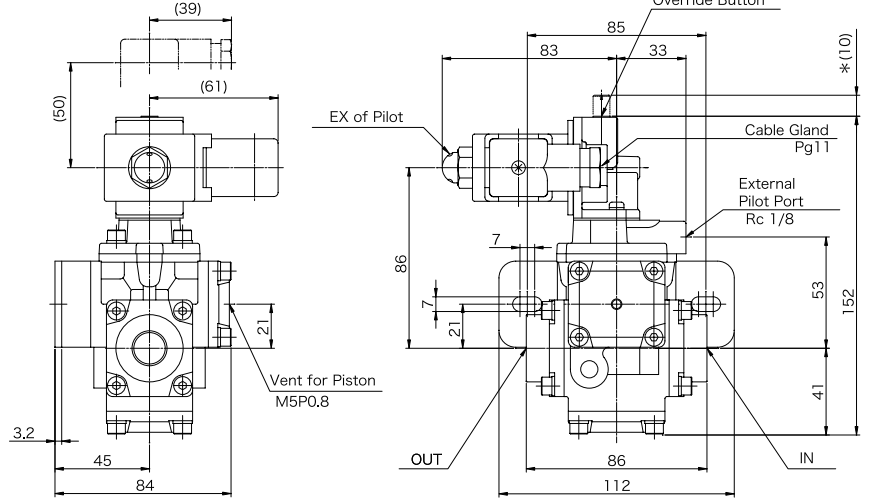
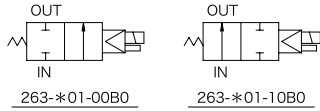

Port Sizes of Each Model

Model Numbers	IN, OUT
263-201-00B0/10B0	Rc1/4
263-301-00B0/10B0	Rc3/8
263-401-00B0/10B0	Rc1/2

*(10) is dimension of a lockable override (option)

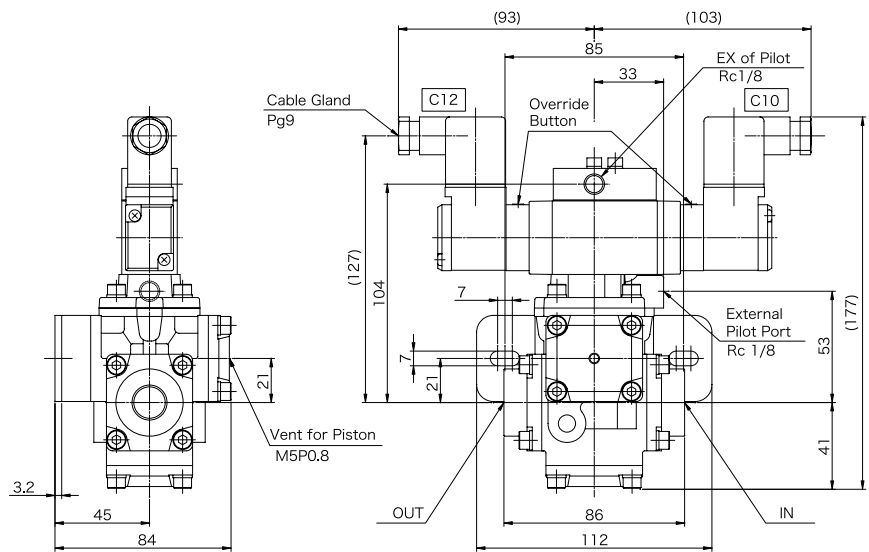
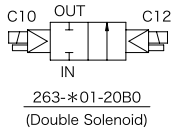

Port Sizes of Each Model

Model Numbers	IN, OUT
263-201-20B0	Rc1/4
263-301-20B0	Rc3/8
263-401-20B0	Rc1/2

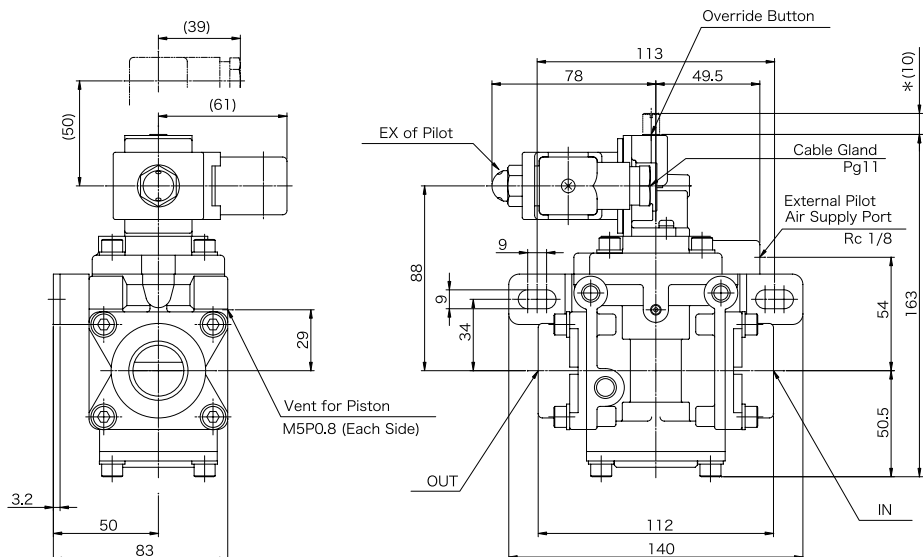
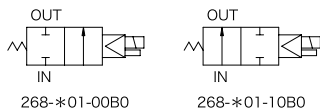

Port Sizes of Each Model

Model Numbers	IN, OUT
268-401-00B0/10B0	Rc1/2
268-601-00B0/10B0	Rc3/4
268-801-00B0/10B0	Rc1
268-A01-00B0/10B0	Rc1-1/4

*(10) is dimension of a lockable override (option)

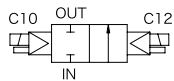

268-*01-20B0
(Double Solenoid)

Port Sizes of Each Model

Model Numbers	IN, OUT
268-401-20B0	Rc1/2
268-601-20B0	Rc3/4
268-801-20B0	Rc1
268-A01-20B0	Rc1 1/4

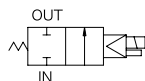
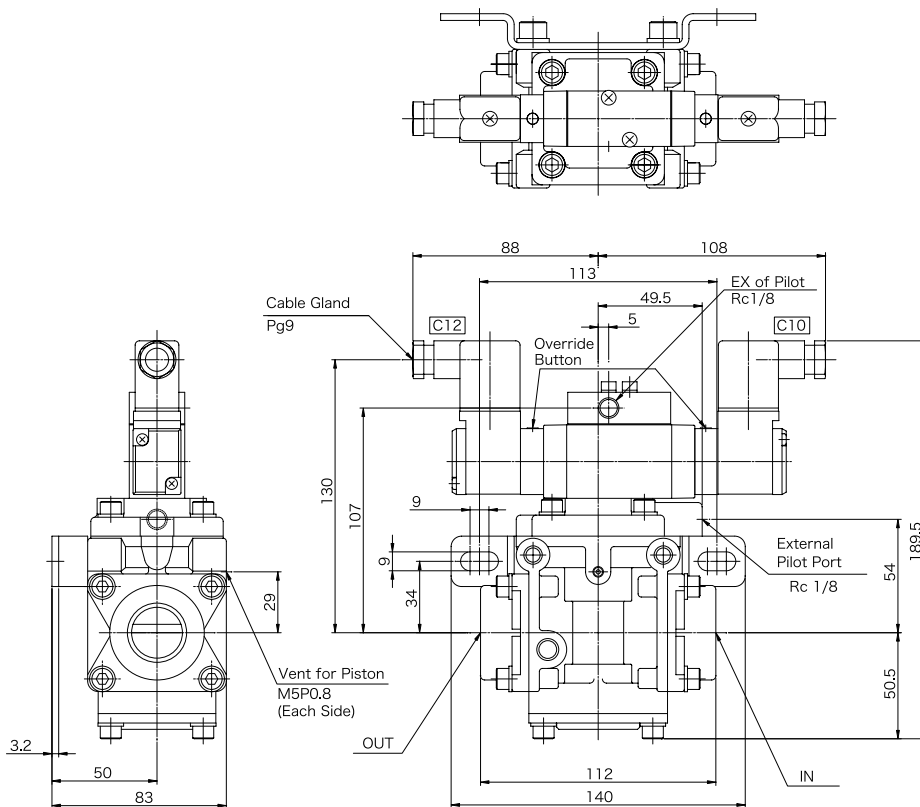

26B-*00-00B0

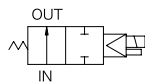

26B-*00-10B0

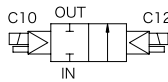

26B-*00-20B0
(Double Solenoid)

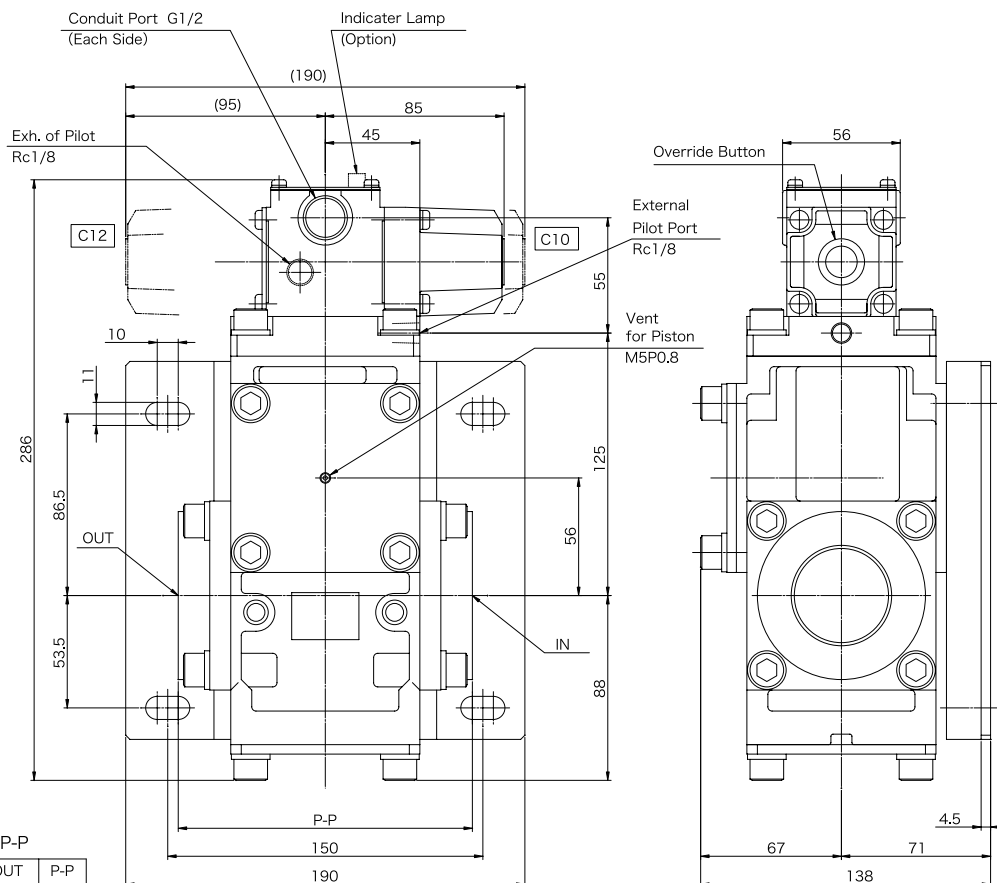

Port Sizes of Each Model, Dims of P-P

Model Numbers	IN, OUT	P-P
26B-A00-00B0/10B0/20B0	Rc1-1/4	140
26B-B00-00B0/10B0/20B0	Rc1-1/2	140
26B-C00-00B0/10B0/20B0	Rc2	146

Dimensions in () are for 26B-*00-20B0; Double Sol.

2 PORT SOLENOID VALVE

260 Super Poppet SERIES (Rc¹/₄~Rc2)

FOR VACUUM

IN-LINE TYPE



SPECIFICATIONS

FLUID	Vacuum (Air)
OPERATING PRESSURE	-0.1 ~ 0MPa (External Pilot Supply type only)
EXTERNAL PILOT SUPPLY PRESSURE	0.2 ~ 0.3MPa
AMBIENT TEMPERATURE	5 ~ 50°C
MANUAL OPERATION	Manual push button/Non-lock type
RATED VOLTAGE	<ul style="list-style-type: none"> • AC-100V 50/60Hz, 110V 60Hz • AC-200V 50/60Hz, 220V 60Hz • DC-24V • DC-100V
VOLTAGE ALLOWANCE	-15 ~ 10%
INSULATION GRADE	Class B

BASIC MODEL NOS. & OTHER SPECIFICATIONS

Pipe Size	MODEL NUMBER		Mass [kg]	Effective Area [mm ²] < Cv value >	
	Single Solenoid			Normally Closed	Normally Open
	Normally Closed	Normally Open			
Rc ¹ / ₄	263-200-03B0	263-200-13B0	1.3	40< 2.2>	40< 2.2>
Rc ³ / ₈	263-300-03B0	263-300-13B0		58< 3.1>	53< 2.9>
Rc ¹ / ₂	263-400-03B0	263-400-13B0		71< 3.8>	63< 3.4>
Rc ¹ / ₂	268-400-03B0	268-400-13B0	2	112< 6.1>	112< 6.1>
Rc ³ / ₄	268-600-03B0	268-600-13B0		170< 9.2>	165< 8.9>
Rc1	268-800-03B0	268-800-13B0		206<11.1>	195<10.5>
Rc1 ¹ / ₄	268-A00-03B0	268-A00-13B0		218<11.8>	206<11.1>
Rc1 ¹ / ₄	26B-A00-03B0	26B-A00-13B0	6.2	450<24.3>	480<25.9>
Rc1 ¹ / ₂	26B-B00-03B0	26B-B00-13B0		510<27.5>	550<29.7>
Rc2	26B-C00-03B0	26B-C00-13B0		570<30.8>	600<32.4>

HOW TO ORDER

26 8 - 8 0 0 - 0 3 B 0 AC-100V

③ ④ ⑦ ⑧ ⑨ ⑩ ⑪

PRODUCT TYPE: 260 SERIES

③ Basic Body Size

3 | 3/8" Basic
8 | 1" Basic
B | 1 1/2" Basic

④ Main Pipe Size

2 | Rc¹/₄
3 | Rc³/₈
4 | Rc¹/₂
6 | Rc³/₄
8 | Rc1
A | Rc1¹/₄
B | Rc1¹/₂
C | Rc2

⑦ Function

0 | Single solenoid,
Normally closed
1 | Single solenoid,
Normally open

⑧ Pilot Air Supply

3 | External Pilot Air Supply

⑨ Accessory

B | Manual push button/Non-lock type
mounting bracket
R | Lock type manual operation button
mounting bracket

⑩ Type of Operator

0 | Solenoid (Std.)
2 | Solenoid with indicator and surge
killer

⑪ Rated Voltage

AC-100V	AC-100V 50/60Hz, 110V 60Hz
AC-200V	AC-200V 50/60Hz, 220V 60Hz
DC-24V	DC-24V
DC-100V	DC-100V

263-*00-03B0

263-*00-13B0

Vacuum by Energizing Pilot Solenoid

Vacuum by De-energizing Pilot Solenoid

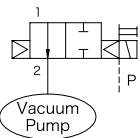
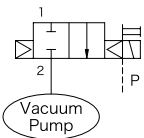

Port sizes of Each Model

Model Numbers	Port Sizes of Port 1 & 2
263-200-03B0/13B0	Rc 1/4
263-300-03B0/13B0	Rc 3/8
263-400-03B0/13B0	Rc 1/2

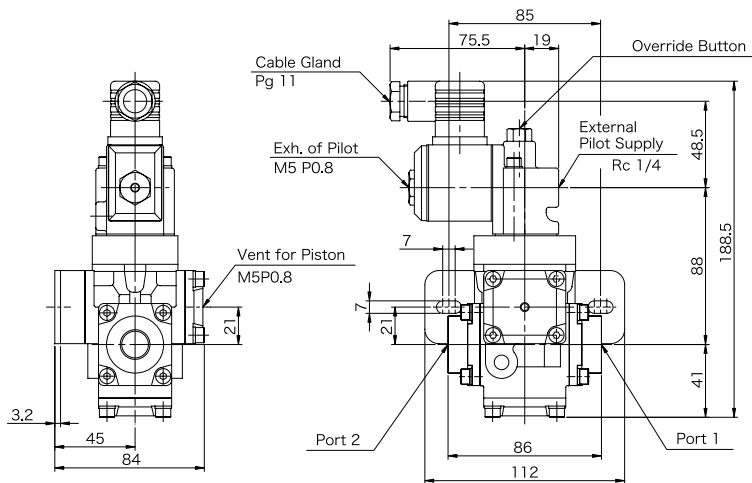

268-*00-03B0

268-*00-13B0

Vacuum by Energizing Pilot Solenoid

Vacuum by De-energizing Pilot Solenoid

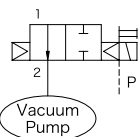
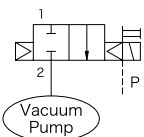

Port sizes of Each Model

Model Numbers	Port Sizes of Port 1 & 2
268-400-03B0/13B0	Rc 1/2
268-600-03B0/13B0	Rc 3/4
268-800-03B0/13B0	Rc 1
268-A00-03B0/13B0	Rc1-1/4

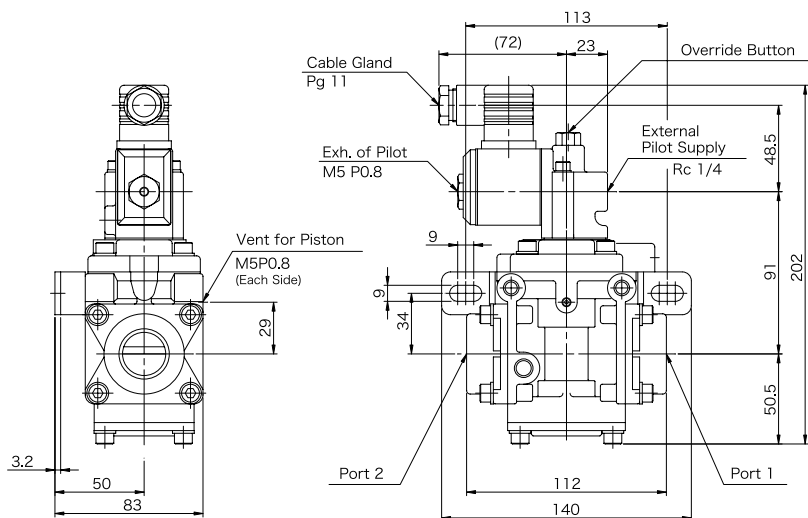

26B-*00-03B0

26B-*00-13B0

Vacuum by Energizing Pilot Solenoid

Vacuum by De-energizing Pilot Solenoid

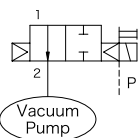
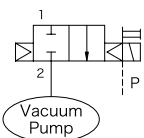

Port sizes of Each Model

Model Numbers	Port Sizes of Port 1 & 2	Dim. P-P
26B-A00-03B0/13B0	Rc1-1/4	140
26B-B00-03B0/13B0	Rc1-1/2	140
26B-C00-03B0/13B0	Rc 2	146

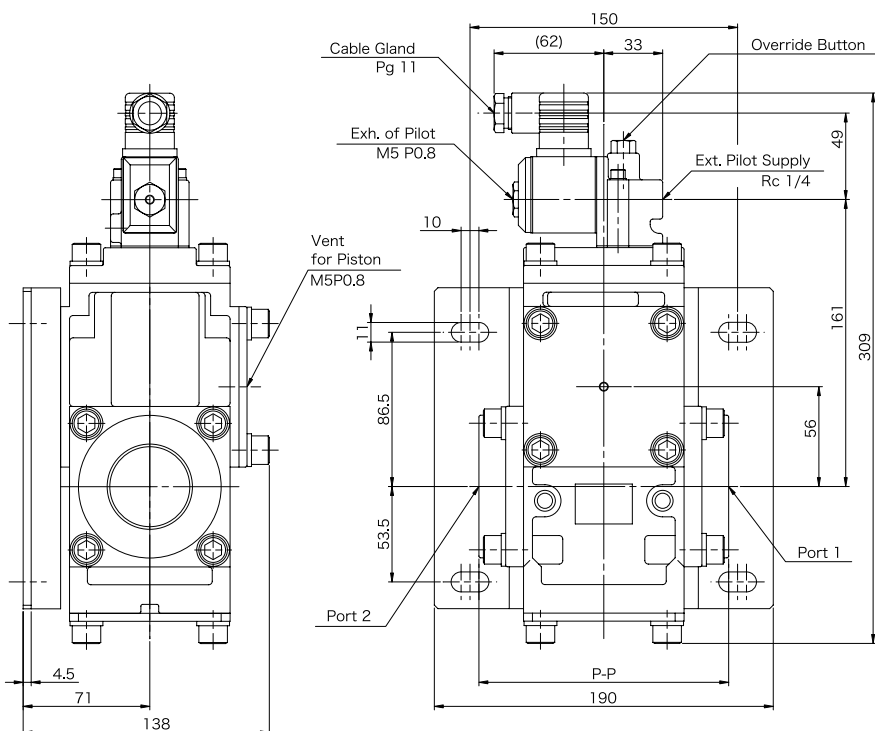

SILENCER

SL-00 SERIES, MFF-200/300 SERIES (R¹/₄~R1, Rc1~Rc2)

SPECIFICATIONS

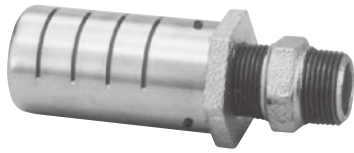

FLUID	Exhaust Air
MAX. OPERATING PRESSURE	1.0MPa
AMBIENT TEMPERATURE	5 ~ 60°C
EXHAUST NOISE REDUCTION RATE	More than 20 dB (A)
NOISE REDUCING ELEMENT	SL-00 Series: sintered brass MFF-200 Series: plastic foam MFF-300 Series: wire-mesh element, or non-woven sheet.



MODEL NOS. & OTHER SPECIFICATIONS

Pipe Size	MODEL NUMBER	Effective Area (mm ²) <Cv>	Mass (kg)
R ¹ / ₄	SL-02	40 < 2.2 >	0.02
R ³ / ₈	SL-03	60 < 3.2 >	0.03
R ¹ / ₂	MFF-204	115 < 6.2 >	0.09
R ³ / ₄	MFF-306A	230 < 12.4 >	0.20
R1(Rc1)	MFF-310	330 < 17.8 >	0.9
Rc1 ¹ / ₄	MFF-312	915 < 49.4 >	
Rc1 ¹ / ₂	MFF-314	975 < 52.7 >	
Rc2	MFF-320	1400 < 75.6 >	1.5

DIMENSIONS

—mm—

SYMBOL



315-033

<p>SL-02</p>	<p>SL-03</p>	<p>MFF-204</p>	
<p>MFF-306A</p>	<p>MFF-310</p> <p>MFF-310 model is combining with a removable pipe nipple for use of Rc1 female thread.</p>		
<p>MFF-312 MFF-314</p>		<p>MFF-320</p>	

5 PORT MASTER VALVE

495 SERIES (Rc^{1/4}, Rc^{3/8})

IN-LINE TYPE

spool valve



SPECIFICATIONS

FLUID	Filtered Compressed Air	
OPERATING PRESSURE	0.2 ~ 1.0MPa	
	Main pressure range	0.2 ~ 1.0MPa
	Pilot pressure range	Same to pressure of main valve or higher.
AMBIENT TEMPERATURE	5 ~ 60°C	
LUBRICANTS	ISO VG32 turbine oil, or equivalent oil is recommended.	

* When the pilot pressure is higher than the pressure supplied to the main valve, the differential pressure should be less than 0.3MPa.

BASIC MODEL NOS. & OTHERS

Pipe Size	Function		MODEL NUMBER	Effective Area [mm ²] < Cv value >	Mass [kg]
Rc ^{1/4}	2 position	Single Pilot	MVM-495-02	35 < 1.9 >	0.5
Rc ^{3/8}			MVM-495-03J		
Rc ^{1/4}	2 position	Double Pilot	MVM-495-02D		0.6
Rc ^{3/8}			MVM-495-03JD		
Rc ^{1/4}	3 position	Closed Center	MVM-435-02		0.8
Rc ^{3/8}			MVM-435-03J		
Rc ^{1/4}	3 position	Exhaust Center	MVM-445-02		
Rc ^{3/8}			MVM-445-03J		
Rc ^{1/4}	3 position	Pressure Center	MVM-455-02		
Rc ^{3/8}			MVM-455-03J		

HOW TO ORDER

MVM-495-02 D

① ② ③

MASTER VALVE

① Function

495	2 position
435	Closed center
445	Exhaust center
455	Pressure center

② Pipe Size

02	Rc ^{1/4}
03	Rc ^{3/8}

③ Port Sizing & Others

D	Double pilot (2 position)
NIL	Full port
J	Over port

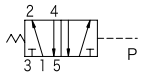

MVM-495-02, 03J

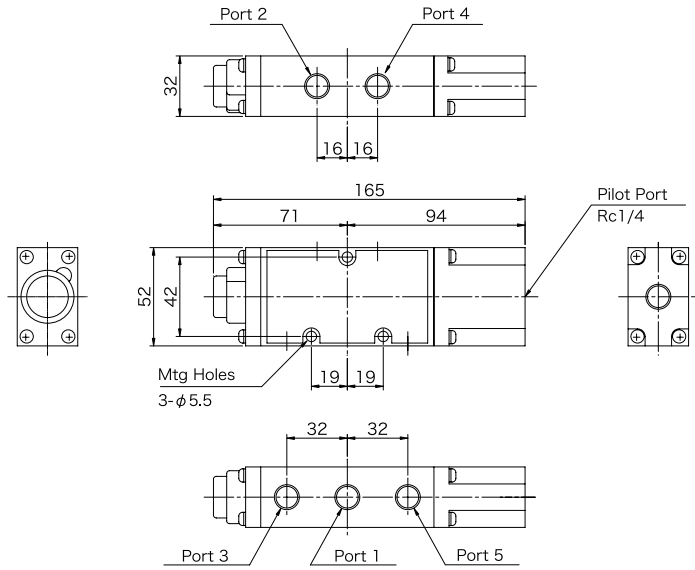

Model Numbers & Port Sizes

Model Numbers	Port 1 to 5
MVM-495-02	Rc1/4
MVM-495-03J	Rc3/8

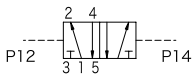

MVM-495-02D, 03JD

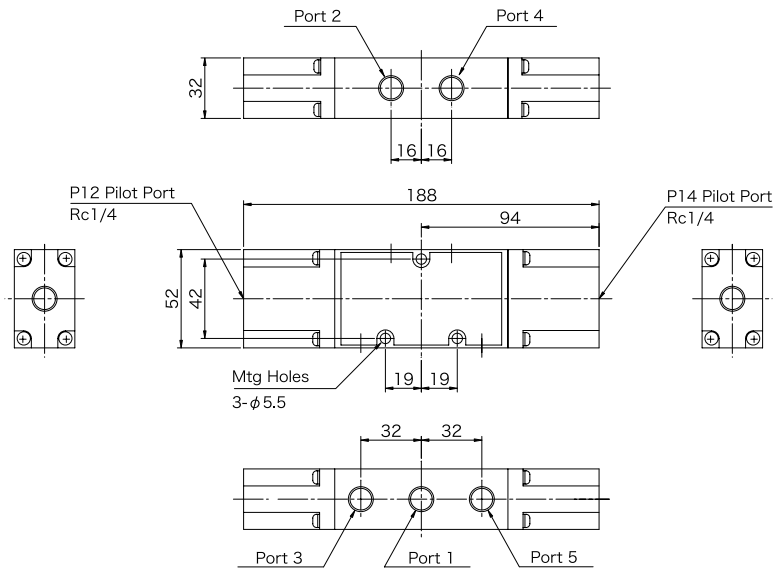

Model Numbers & Port Sizes

Model Numbers	Port 1 to 5
MVM-495-02D	Rc1/4
MVM-495-03JD	Rc3/8

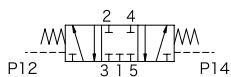

MVM-435-02, 03J

Closed Center

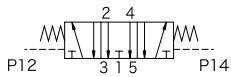

MVM-445-02, 03J

Exhaust Center

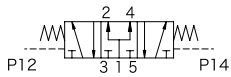

MVM-455-02, 03J

Pressure Center

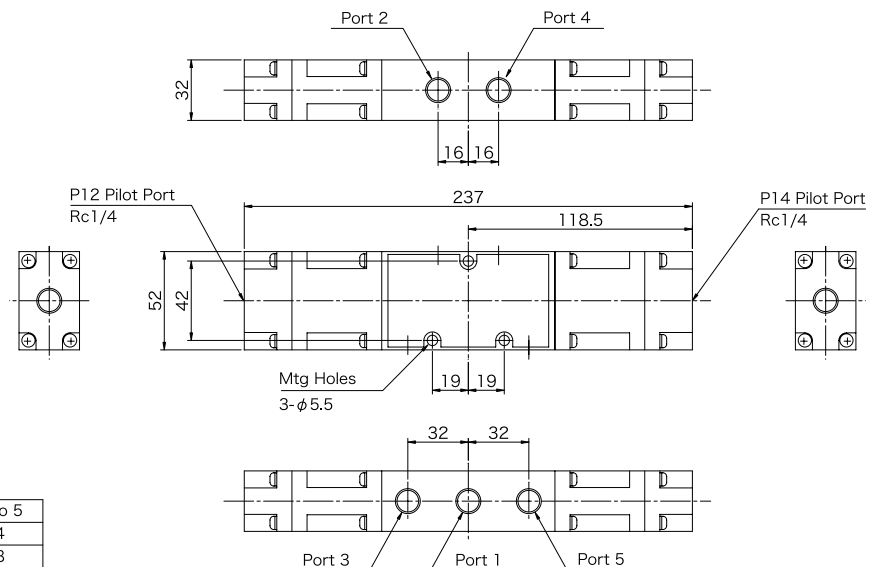

Model Numbers & Port Sizes

Model Numbers	Port 1 to 5
MVM-435/445/455-02	Rc1/4
MVM-435/445/455-03J	Rc3/8

5 PORT MASTER VALVE

492 SERIES (Rc^{1/4}, Rc^{3/8})

SUB-BASE TYPE

spool valve

SPECIFICATIONS

FLUID	Filtered Compressed Air	
OPERATING PRESSURE	0.2 ~1.0MPa	
	Main pressure range	0.2 ~1.0MPa
	Pilot pressure range	Same to pressure of main valve or higher.
AMBIENT TEMPERATURE	5 ~ 60°C	
LUBRICANTS	ISO VG32 turbine oil, or equivalent oil is recommended.	

* When the pilot pressure is higher than the pressure supplied to the main valve, the differential pressure should be less than 0.3MPa.

BASIC MODEL NOS. & OTHERS

Pipe Size	Function		MODEL NUMBER	Effective Area [mm ²] < Cv value >	Mass [kg]
Rc ^{1/4}	2 position	Single Pilot	MVM-492-02	35 < 1.9 >	0.85
Rc ^{3/8}			MVM-492-03J		
Rc ^{1/4}	2 position	Double Pilot	MVM-492-02D		1.0
Rc ^{3/8}			MVM-492-03JD		
Rc ^{1/4}	3 position	Closed Center	MVM-432-02		1.1
Rc ^{3/8}			MVM-432-03J		
Rc ^{1/4}	3 position	Exhaust Center	MVM-442-02		
Rc ^{3/8}			MVM-442-03J		
Rc ^{1/4}	3 position	Pressure Center	MVM-452-02		
Rc ^{3/8}			MVM-452-03J		

HOW TO ORDER

MVM - 492 - 02 D

① ② ③

MASTER VALVE

① Function

492	2 position
432	Closed center
442	Exhaust center
452	Pressure center

② Pipe Size

02	Rc ^{1/4}
03	Rc ^{3/8}

③ Port Sizing & Others

D	Double pilot (2 position)
NIL	Full port
J	Over port

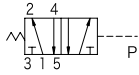

MVM-492-02, 03J

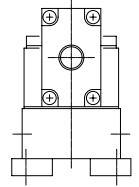
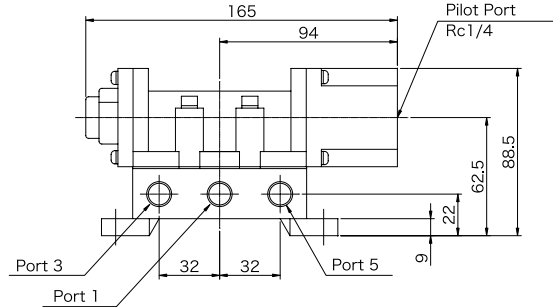
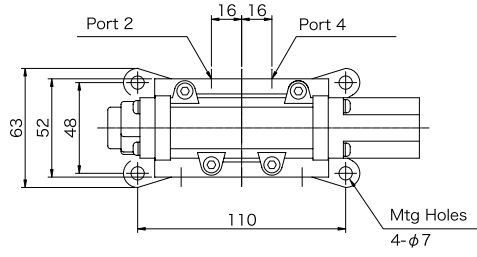

Model Numbers & Port Sizes

Model Numbers	Port 1 to 5
MVM-492-02	Rc1/4
MVM-492-03J	Rc3/8

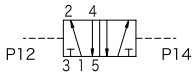

MVM-492-02D, 03JD

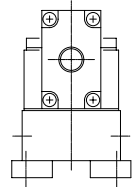
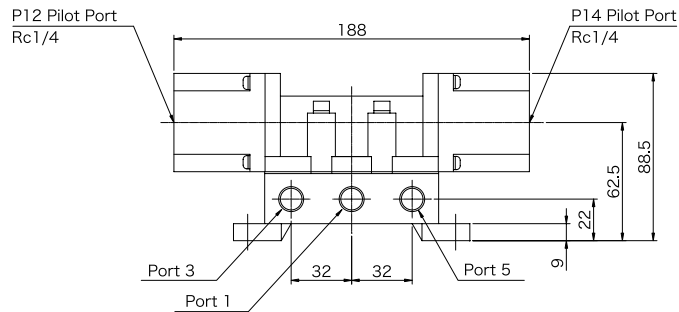
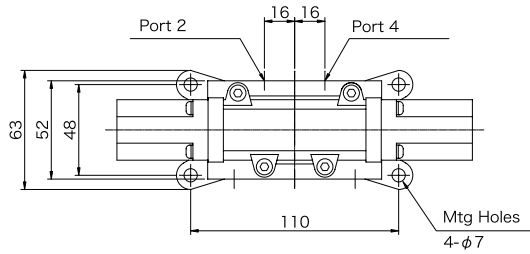

Model Numbers & Port Sizes

Model Numbers	Port 1 to 5
MVM-492-02D	Rc1/4
MVM-492-03JD	Rc3/8

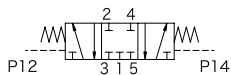

MVM-432-02, 03J

Closed Center

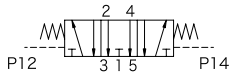

MVM-442-02, 03J

Exhaust Center

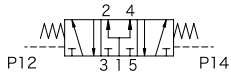

MVM-452-02, 03J

Pressure Center

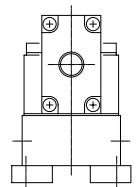
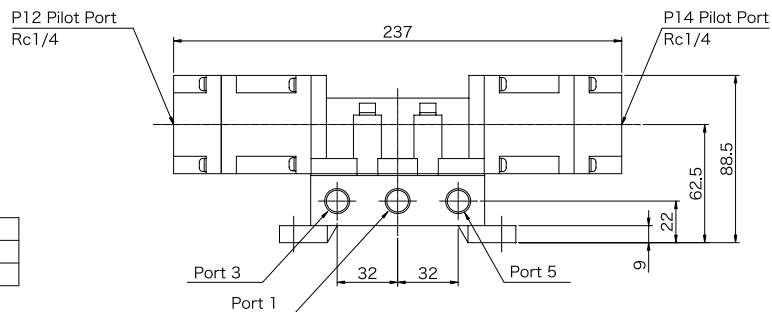
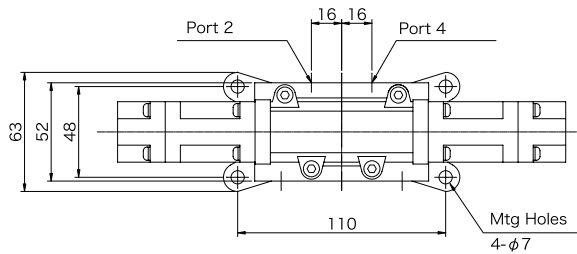

Model Numbers & Port Sizes

Model Numbers	Port 1 to 5
MVM-432/442/452-02	Rc1/4
MVM-432/442/452-03J	Rc3/8

5 PORT MASTER VALVE

524 SERIES (Rc^{1/4}~Rc^{3/4})

SUB-BASE TYPE

spool valve

SPECIFICATIONS

FLUID	Filtered compressed Air		
OPERATING PRESSURE	0 ~ 1.0MPa		
	Main pressure range	0 ~ 0.2MPa	0.2 ~ 1.0MPa
	Pilot pressure range	0.2 ~ 0.3MPa	Same to pressure of main valve or higher.
AMBIENT TEMPERATURE	5 ~ 60°C		
LUBRICANTS	ISO VG32 turbine oil, or equivalent oil is recommended.		

* When the pilot pressure is higher than the pressure supplied to the main valve, the differential pressure should be less than 0.3MPa.

BASIC MODEL NOS. & OTHERS

Pipe Size	Function		MODEL NUMBER	Effective Area [mm ²]	Mass [kg]
Rc ^{1/4}	2 position	Single Pilot	524-200-100M	42	1.7
Rc ^{3/8}			524-300-100M	68	
Rc ^{1/2}			524-400-100M	80	
Rc ^{3/4}			524-600-100M	80	1.8
Rc ^{1/4}	2 position	Double Pilot	524-200-200M	42	1.9
Rc ^{3/8}			524-300-200M	68	
Rc ^{1/2}			524-400-200M	80	
Rc ^{3/4}			524-600-200M	80	2.0
Rc ^{1/4}	3 position	Closed Center	524-200-300M	41	2.0
Rc ^{3/8}			524-300-300M	60	
Rc ^{1/2}			524-400-300M	75	
Rc ^{3/4}			524-600-300M	75	2.1
Rc ^{1/4}	3 position	Exhaust Center	524-200-400M	41	2.0
Rc ^{3/8}			524-300-400M	60	
Rc ^{1/2}			524-400-400M	75	
Rc ^{3/4}			524-600-400M	75	2.1
Rc ^{1/4}	3 position	Pressure Center	524-200-500M	41	2.0
Rc ^{3/8}			524-300-500M	60	
Rc ^{1/2}			524-400-500M	75	
Rc ^{3/4}			524-600-500M	75	2.1

HOW TO ORDER

5 2 4 - 4 0 0 - 1 0 0 M

④ ⑦ ⑩

PRODUCT SERIES

④ Pipe Size

- 2 | Rc^{1/4}
- 3 | Rc^{3/8}
- 4 | Rc^{1/2}
- 6 | Rc^{3/4}

⑦ Function

- 1 | 2 position
- 2 | Duple (2 position)
- 3 | Closed center
- 4 | Exhaust center
- 5 | Pressure center

⑩ Operator

- M | Master valve

DIMENSIONS

—mm—

524 Series Master Valve

310-053-A

3J-7236

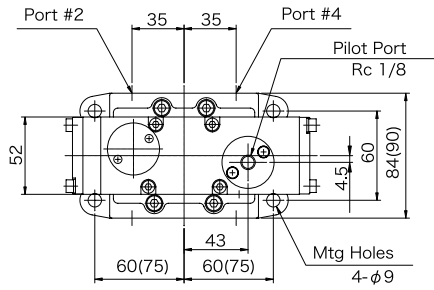

524*00-100M
2-Position Single Type

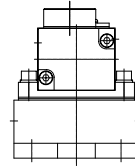
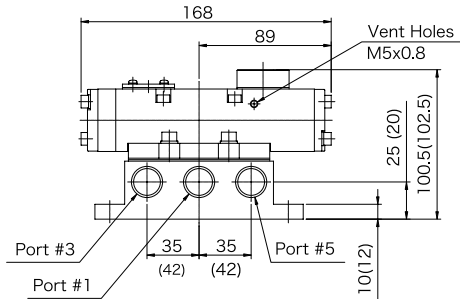
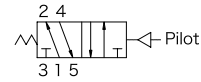

Dims in () are for Rc3/4 unit.

3J-7237

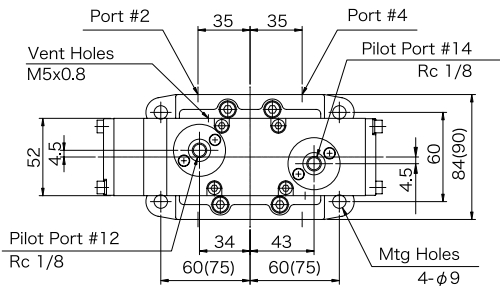

524*00-200M
2-Position Double Type

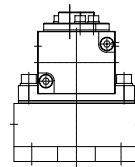
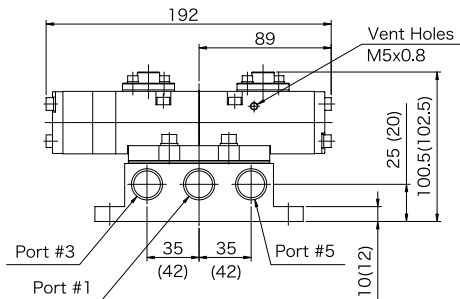
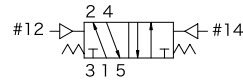

Dims in () are for Rc3/4 unit.

3J-7238

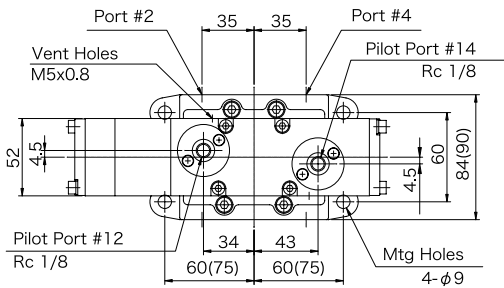

524*00-300M
Closed Center Type

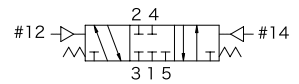

524*00-400M
Exhaust Center Type

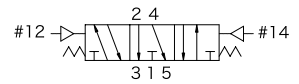

524*00-500M
Pressure Center Type

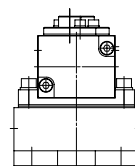
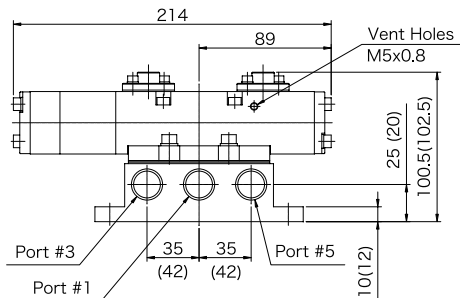
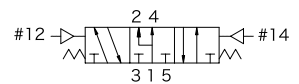

Dims in () are for Rc3/4 unit.

5 PORT MASTER VALVE

491 SERIES (Rc³/₄~Rc1¹/₄)

SUB-BASE TYPE

spool valve

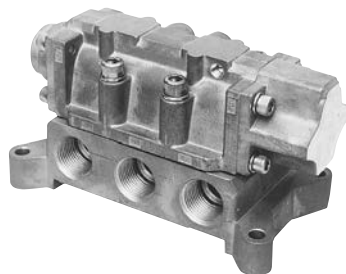

SPECIFICATIONS

FLUID	Filtered Compressed Air	
OPERATING PRESSURE	0.15 ~1.0MPa	
	Main pressure range	0.15 ~1.0MPa
	Pilot pressure range	Same to pressure of main valve or higher.
AMBIENT TEMPERATURE	5 ~ 60°C	
LUBRICANTS	ISO VG32 turbine oil, or equivalent oil is recommended.	

* When the pilot pressure is higher than the pressure supplied to the main valve, the differential pressure should be less than 0.3MPa.

BASIC MODEL NOS. & OTHERS

Pipe Size	Function		MODEL NUMBER	Effective Area [mm ²] < Cv value >	Mass [kg]
Rc ³ / ₄	2 position	Single Pilot	MVM-491-06	185 < 10.0 >	3.5
Rc1			MVM-491-10	195 < 10.7 >	
Rc1 ¹ / ₄			MVM-491-12J	215 < 11.8 >	4.3
Rc ³ / ₄	2 position	Double Pilot	MVM-491-06D	185 < 10.0 >	4.2
Rc1			MVM-491-10D	195 < 10.7 >	
Rc1 ¹ / ₄			MVM-491-12JD	215 < 11.8 >	5.0
Rc ³ / ₄	3 position	Closed Center	MVM-431-06	185 < 10.0 >	4.5
Rc1			MVM-431-10	195 < 10.7 >	
Rc1 ¹ / ₄			MVM-431-12J	215 < 11.8 >	6.3
Rc ³ / ₄	3 position	Exhaust Center	MVM-441-06	185 < 10.0 >	4.5
Rc1			MVM-441-10	195 < 10.7 >	
Rc1 ¹ / ₄			MVM-441-12J	215 < 11.8 >	6.3
Rc ³ / ₄	3 position	Pressure Center	MVM-451-06	185 < 10.0 >	4.5
Rc1			MVM-451-10	195 < 10.7 >	
Rc1 ¹ / ₄			MVM-451-12J	215 < 11.8 >	6.3

HOW TO ORDER

MVM - 491 - 10 D

① ② ③

MASTER VALVE

① Function

491	2 position
431	Closed center
441	Exhaust center
451	Pressure center

② Pipe Size

06	Rc ³ / ₄
10	Rc1
12	Rc1 ¹ / ₄

③ Port Sizing & Others

D	Double pilot (2 position)
NIL	Full port
J	Over port

MVM-491-06, 10, 12J

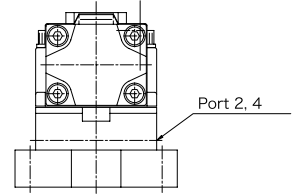
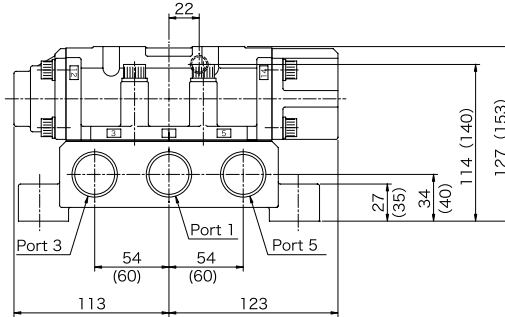
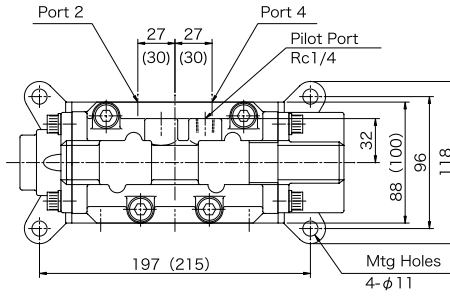
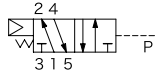

Port Sizes of Each Model

Model Nos.	Port Sizes
MVM-491-06	Rc3/4
MVM-491-10	Rc1
MVM-491-12J	Rc1-1/4

Dimensions () are applied to model MVM-491-12J.

MVM-491-06D, 10D, 12JD

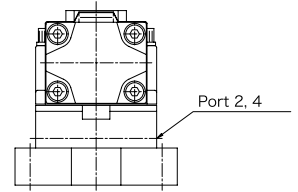
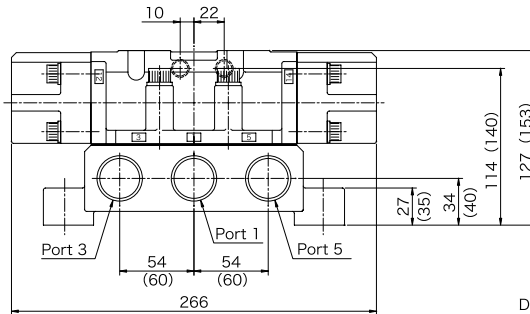
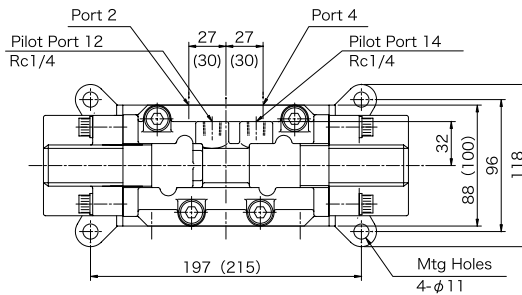
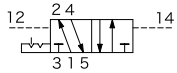

Port Sizes of Each Model

Model Nos.	Port Sizes
MVM-491-06D	Rc3/4
MVM-491-10D	Rc1
MVM-491-12JD	Rc1-1/4

Dimensions () are applied to model MVM-491-12JD.

MVM-431-06, 10, 12J

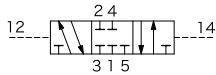

MVM-441-06, 10, 12J

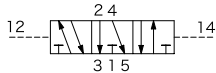

MVM-451-06, 10, 12J

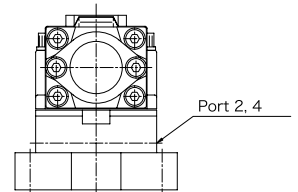
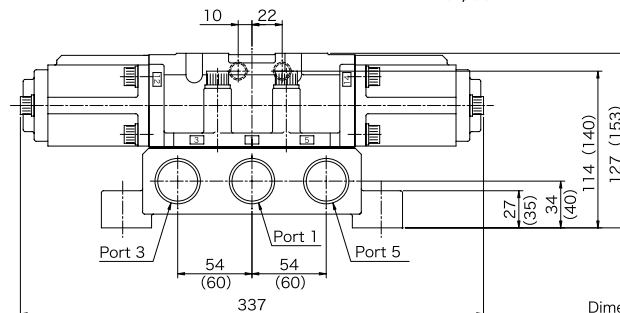
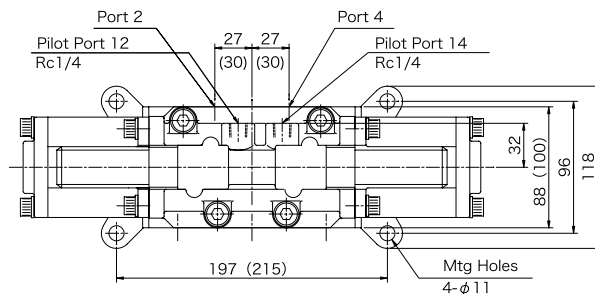
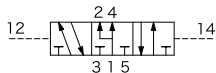

Port Sizes of Each Model

Model Nos.	Port Sizes
MVM-431/441/451-06	Rc3/4
MVM-431/441/451-10	Rc1
MVM-431/441/451-12J	Rc1-1/4

Dimensions () are applied to model MVM-431-12J, model MVM-441-12J, and model MVM-451-12J.

5 PORT MASTER VALVE

491 SERIES (Rc1¹/₄~Rc1¹/₂)

SUB-BASE TYPE

spool valve

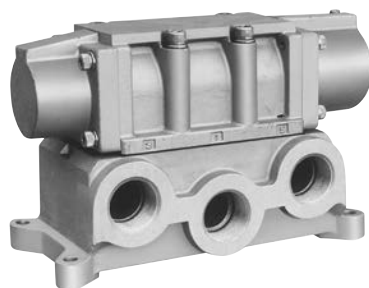

SPECIFICATIONS

FLUID	Filtered Compressed Air	
OPERATING PRESSURE	0.15 ~1.0MPa	
	Main pressure range	0.15 ~1.0MPa
	Pilot pressure range	Same to pressure of main valve or higher.
AMBIENT TEMPERATURE	5 ~ 60°C	
LUBRICANTS	ISO VG32 turbine oil, or equivalent oil is recommended.	

* When the pilot pressure is higher than the pressure supplied to the main valve, the differential pressure should be less than 0.3MPa.

BASIC MODEL NOS. & OTHERS

Pipe Size	Function		MODEL NUMBER	Effective Area [mm ²] < Cv value >	Mass [kg]
Rc1 ¹ / ₄	2 position	Single Pilot	MVM-491-12	330<17.9>	8.5
Rc1 ¹ / ₂			MVM-491-14	350<19.0>	
Rc1 ¹ / ₄	2 position	Double Pilot	MVM-491-12D	330<17.9>	10.8
Rc1 ¹ / ₂			MVM-491-14D	350<19.0>	
Rc1 ¹ / ₄	3 position	Closed Pilot	MVM-431-12	330<17.9>	11.3
Rc1 ¹ / ₂			MVM-431-14	350<19.0>	
Rc1 ¹ / ₄	3 position	Exhaust Center	MVM-441-12	330<17.9>	11.3
Rc1 ¹ / ₂			MVM-441-14	350<19.0>	
Rc1 ¹ / ₄	3 position	Pressure Center	MVM-451-12	330<17.9>	11.3
Rc1 ¹ / ₂			MVM-451-14	350<19.0>	

HOW TO ORDER

MVM - 4 9 1 - 1 2 D

① ② ③

MASTER VALVE

① Function

491	2 position
431	Closed center
441	Exhaust center
451	Pressure center

② Pipe Size

12	Rc1 ¹ / ₄
14	Rc1 ¹ / ₂

③ Port Sizing & Others

D	Double pilot (2 position)
NIL	Full port

MVM-491-12, 14

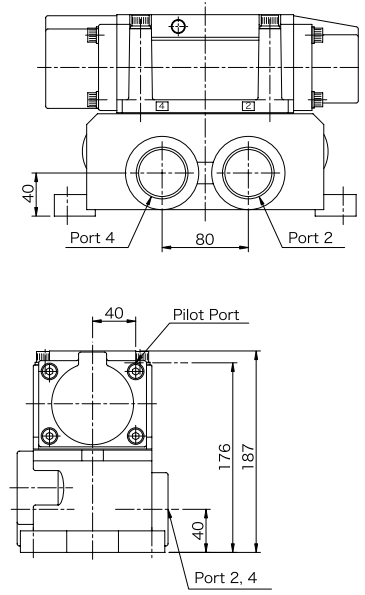
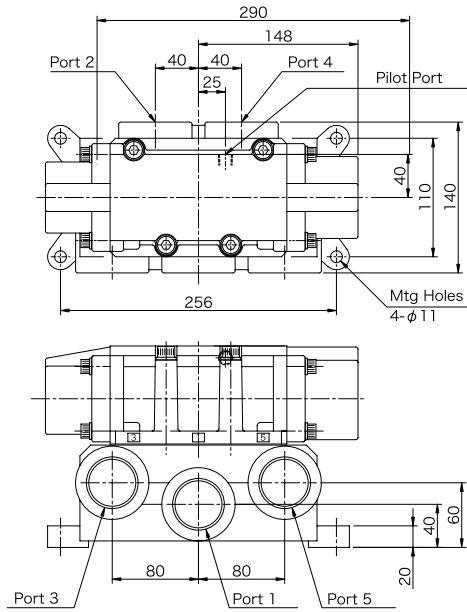
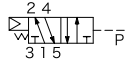

Port Sizes of Each Model

Model Nos.	Port Sizes
MVM-491-12	Rc1-1/4
MVM-491-14	Rc1-1/2

MVM-491-12D,14D

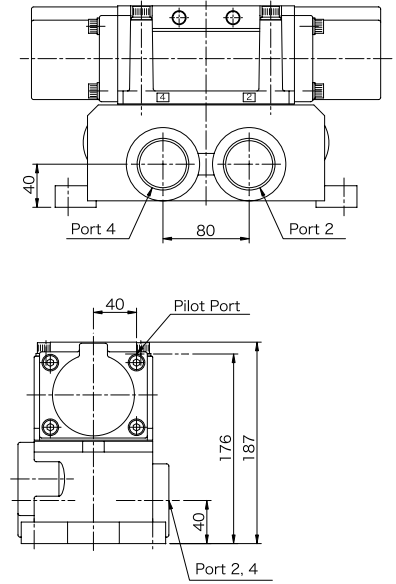
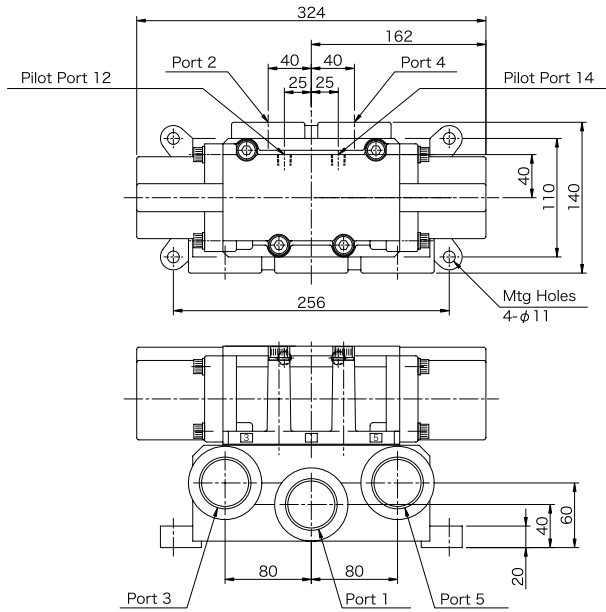

Port Sizes of Each Model

Model Nos.	Port Sizes
MVM-491-12D	Rc1-1/4
MVM-491-14D	Rc1-1/2

MVM-431-12,14

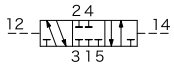

MVM-441-12,14

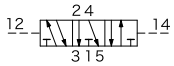

MVM-451-12,14

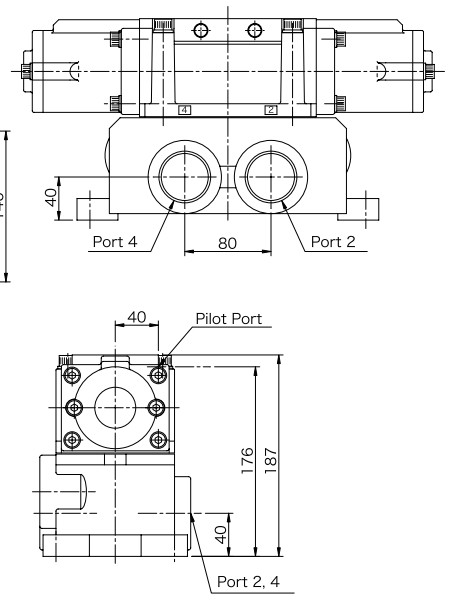
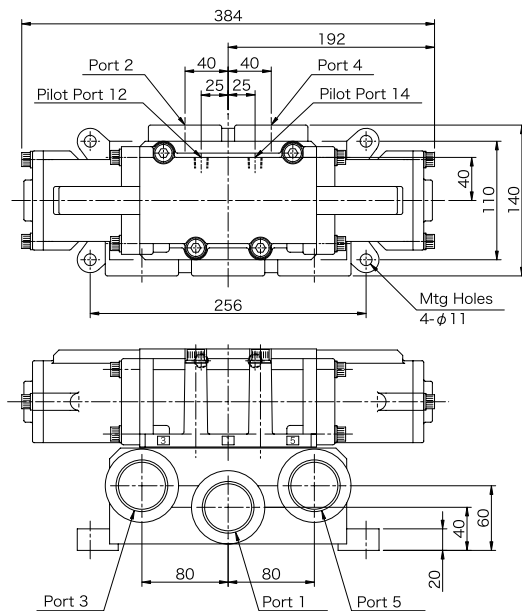

Port Sizes of Each Model

Model Nos.	Port Sizes
MVM-431/441/451-12	Rc1-1/4
MVM-431/441/451-14	Rc1-1/2

4 PORT MASTER VALVE

460 Super Poppet SERIES (Rc¹/₄~Rc2)

IN-LINE TYPE

Poppet valve

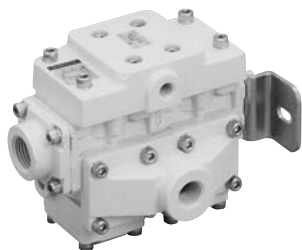

SPECIFICATIONS

FLUID	Filtered Compressed Air		
OPERATING PRESSURE	0.05 ~ 1.0MPa		
	Main pressure range	0.05 ~ 0.15MPa	0.15 ~ 1.0MPa
	Pilot pressure range	0.15 ~ 0.3MPa	Same to pressure of main valve or higher.
AMBIENT TEMPERATURE	5 ~ 60°C		
PROOF PRESSURE	1.6MPa		
LUBRICANTS	ISO VG32 turbine oil, or equivalent oil is recommended.		

* When the pilot pressure is higher than the pressure supplied to the main valve, the differential pressure should be less than 0.3MPa.

* Pilot pressure must not exceed 1.0MPa.

BASIC MODEL NOS. & OTHERS

Port Size		MODEL NUMBER 2 Position Single Pilot	Effective Area [mm ²] < Cv value >				Mass [kg]
IN-OUT	EX		IN-OUT		OUT-EX		
			IN→01	IN→02	01→EX	02→EX	
Rc ¹ / ₄	Rc ¹ / ₂	463-200-10BM	42.5<2.3>	42.5<2.3>	53< 2.9>	53< 2.9>	1.4
Rc ³ / ₈		463-300-10BM	56< 3.0>	56< 3.0>	67< 3.6>	80< 4.3>	
Rc ¹ / ₂		463-400-10BM	60< 3.2>	67< 3.6>	71< 3.8>	90< 4.9>	
Rc ¹ / ₂	Rc1	468-400-10BM	112< 6.1>	118< 6.4>	150< 8.1>	160< 8.6>	3.1
Rc ³ / ₄		468-600-10BM	160< 8.6>	170< 9.2>	190<10.3>	180< 9.7>	
Rc1		468-800-10BM	180< 9.7>	190<10.3>	190<10.3>	200<10.8>	
Rc1 ¹ / ₄	Rc1 ¹ / ₄	468-A00-10BM	180< 9.7>	190<10.3>	190<10.3>	200<10.8>	10.9
Rc1 ¹ / ₄	Rc2	46B-A00-10BM	400<21.6>	450<24.3>	425<23.0>	530<28.6>	
Rc1 ¹ / ₂		46B-B00-10BM	480<25.9>	500<27.0>	500<27.0>	560<30.2>	
Rc2		46B-C00-10BM	480<25.9>	530<28.6>	500<27.0>	560<30.2>	

HOW TO ORDER

468-800-10BM

③ ④ ⑦⑧⑨⑩

460 SERIES
4-PORT MASTER VALVE

③ Basic Body Size

3 3/8" Body
8 1" Body
B 1 1/2" Body

④ Pipe Size

2 Rc¹/₄
3 Rc³/₈
4 Rc¹/₂
6 Rc³/₄
8 Rc1
A Rc1¹/₄
B Rc1¹/₂
C Rc2

⑦ Function

1 2 Position, Single pilot

⑧ Type of Operation

0 Air pilot
(Master valve)

⑨ Accessory

B With Mounting Bracket (Std.)

⑩ Operator

M Air pilot Spring return

DIMENSIONS

—mm—

460 Series, 4-Port Master Valve, 2-Position

310-095

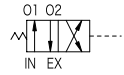

463-*00-10BM

Port Sizes of Each Model

Model Numbers	IN & OUT	EX
463-200-10BM	Rc1/4	Rc1/2
463-300-10BM	Rc3/8	
463-400-10BM	Rc1/2	

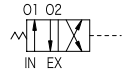
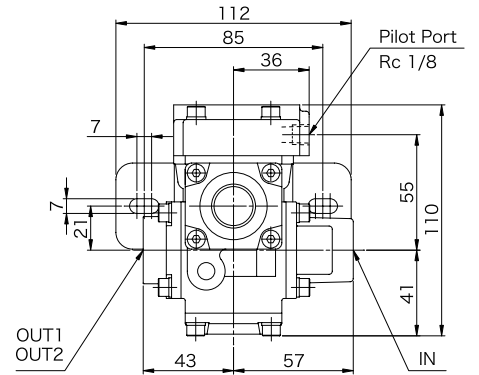
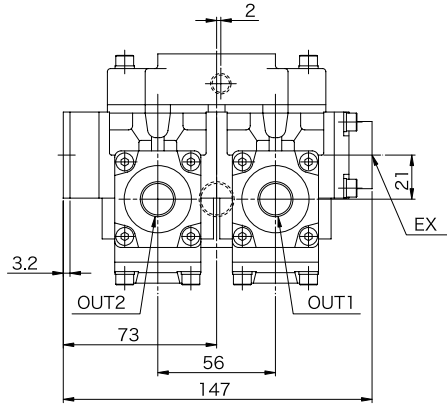

468-*00-10BM

Port Sizes of Each Model

Model Numbers	IN & OUT	EX
468-400-10BM	Rc1/2	Rc1
468-600-10BM	Rc3/4	
468-800-10BM	Rc1	Rc1-1/4
468-A00-10BM	Rc1-1/4	

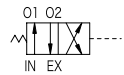
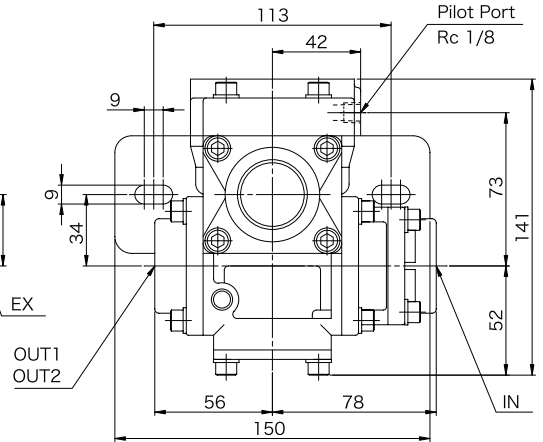
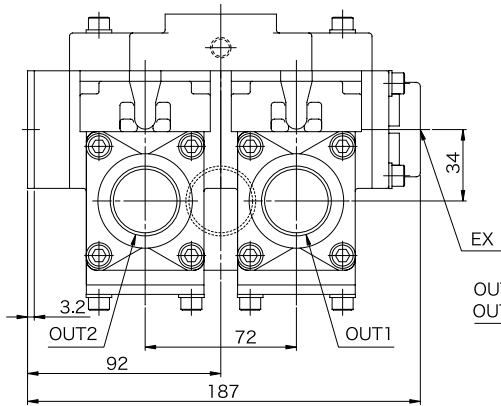

46B-*00-10B0

Port Sizes of Each Model

Model Numbers	IN & OUT	EX
46B-A00-10BM	Rc1-1/4	Rc2
46B-B00-10BM	Rc1-1/2	
46B-C00-10BM	Rc2	

Dimensions in () are for 46B-C00 unit.

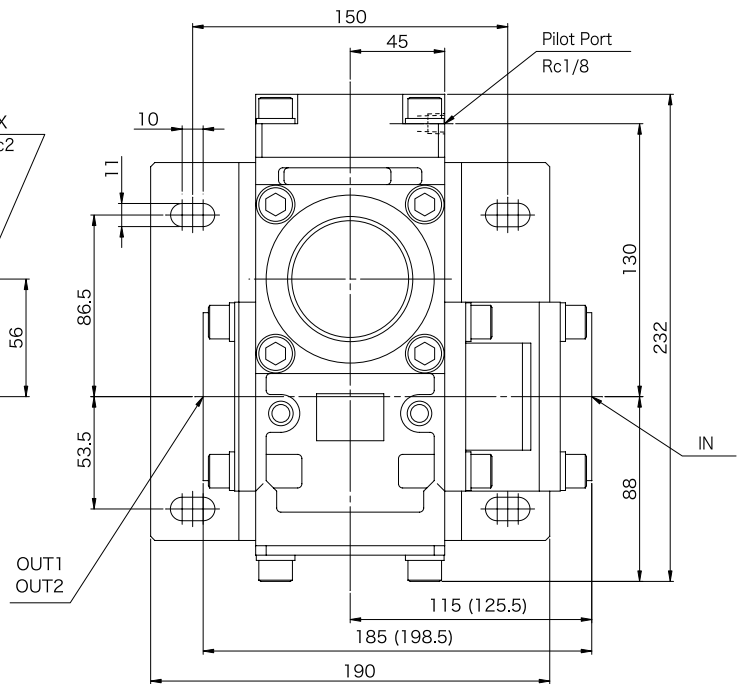
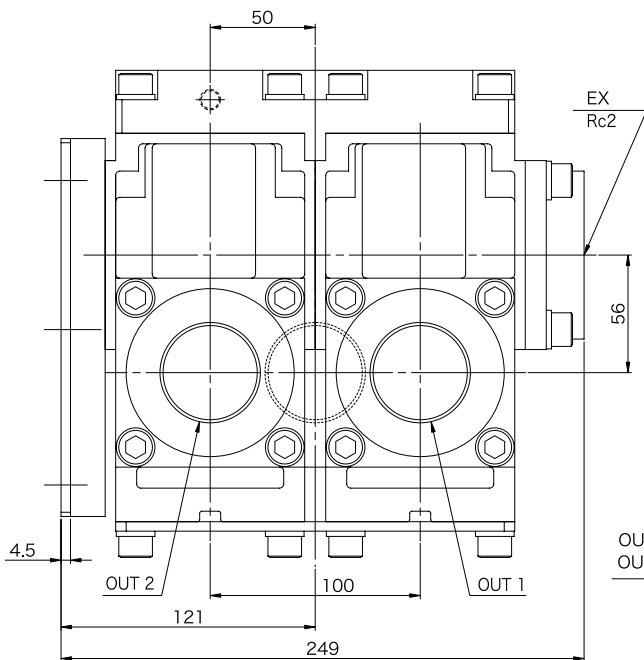

(By Dwg 3J-7221A, -7222A, 7223A)

4 PORT MASTER VALVE

460 Super Poppet SERIES (Rc¹/₄~Rc2)

3-POSITION IN-LINE TYPE

Poppet valve

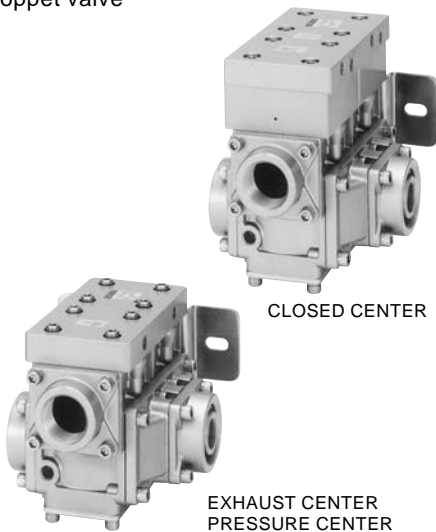

SPECIFICATIONS

FLUID	Filtered Compressed Air		
OPERATING PRESSURE	0.05 ~ 1.0MPa		
	Main pressure range	0.05 ~ 0.15MPa	0.15 ~ 1.0MPa
	Pilot pressure range	0.15 ~ 0.3MPa	Same to pressure of main valve or higher.
AMBIENT TEMPERATURE	5 ~ 60°C		
PROOF PRESSURE	1.6MPa		
LUBRICANTS	ISO VG32 turbine oil, or equivalent oil is recommended.		

* When the pilot pressure is higher than the pressure supplied to the main valve, the differential pressure should be less than 0.3MPa.

BASIC MODEL NOS. & OTHERS

Port Size		Function	MODEL NUMBER	Effective Area (mm ²) < Cv value >				Mass [kg]
IN-OUT	EX			IN-01	IN-02	01-EX	02-EX	
Rc ¹ / ₄	Rc ¹ / ₂	Closed Center 	463-200-30BM	43 < 2.3 >	43 < 2.3 >	58 < 3.1 >	56 < 3.0 >	2.5
Rc ³ / ₈			463-300-30BM	63 < 3.4 >	63 < 3.4 >	88 < 4.7 >	73 < 3.9 >	
Rc ¹ / ₂			463-400-30BM	76 < 4.1 >	76 < 4.1 >	100 < 5.4 >	80 < 4.3 >	
Rc ¹ / ₂	Rc1		468-400-30BM	124 < 6.7 >	124 < 6.7 >	175 < 9.4 >	150 < 8.1 >	4.8
Rc ³ / ₈			468-600-30BM	175 < 9.4 >	175 < 9.4 >	250 < 13.5 >	180 < 9.7 >	
Rc1			468-800-30BM	200 < 10.8 >	200 < 10.8 >	282 < 15.2 >	195 < 10.5 >	
Rc ¹ / ₄	Rc1 ¹ / ₄		468-A00-30BM	200 < 10.8 >	200 < 10.8 >	282 < 15.4 >	186 < 10.0 >	13.9
Rc ¹ / ₄			46B-A00-30BM	540 < 29.2 >	540 < 29.2 >	590 < 31.9 >	380 < 20.5 >	
Rc ¹ / ₂			46B-B00-30BM	540 < 29.2 >	540 < 29.2 >	630 < 34.0 >	380 < 20.5 >	
Rc ¹ / ₂	Rc2		46B-C00-30BM	545 < 29.5 >	545 < 29.5 >	680 < 36.7 >	390 < 21.1 >	11.5
Rc ¹ / ₄			463-200-40BM	37 < 2.0 >	37 < 2.0 >	41 < 2.2 >	40 < 2.1 >	
Rc ³ / ₈			463-300-40BM	58 < 3.1 >	58 < 3.1 >	78 < 4.2 >	65 < 3.5 >	
Rc ¹ / ₂	Rc1		463-400-40BM	70 < 3.7 >	70 < 3.7 >	104 < 5.6 >	75 < 4.0 >	3.7
Rc ³ / ₄			468-400-40BM	122 < 6.5 >	122 < 6.5 >	170 < 9.1 >	130 < 7.0 >	
Rc1			468-600-40BM	170 < 9.1 >	170 < 9.1 >	245 < 13.2 >	145 < 7.8 >	
Rc ¹ / ₄	Rc1 ¹ / ₄		468-800-40BM	195 < 10.5 >	195 < 10.5 >	280 < 15.1 >	150 < 8.1 >	11.5
Rc ¹ / ₄			468-A00-40BM	450 < 24.3 >	450 < 24.3 >	540 < 29.2 >	265 < 14.3 >	
Rc ¹ / ₂			46B-B00-40BM	510 < 27.6 >	510 < 27.6 >	645 < 34.9 >	270 < 14.6 >	
Rc2	Rc2		46B-C00-40BM	525 < 28.4 >	525 < 28.4 >	680 < 36.7 >	270 < 14.6 >	2.0
Rc ¹ / ₄			463-200-50BM	35 < 1.8 >	35 < 1.8 >	40 < 2.1 >	40 < 2.1 >	
Rc ³ / ₈			463-300-50BM	50 < 2.7 >	50 < 2.7 >	66 < 3.5 >	64 < 3.4 >	
Rc ¹ / ₂	Rc1 ¹ / ₄		463-400-50BM	53 < 2.8 >	53 < 2.8 >	73 < 3.9 >	70 < 4.0 >	3.7
Rc ³ / ₄			468-400-50BM	120 < 6.4 >	120 < 6.4 >	153 < 8.2 >	145 < 7.8 >	
Rc1			468-600-50BM	175 < 9.4 >	175 < 9.4 >	185 < 10.0 >	170 < 9.1 >	
Rc ¹ / ₄	Rc2		468-800-50BM	190 < 10.2 >	200 < 10.8 >	200 < 10.8 >	180 < 9.7 >	11.5
Rc ¹ / ₄			468-A00-50BM	184 < 9.9 >	192 < 10.3 >	198 < 10.7 >	177 < 9.5 >	
Rc ¹ / ₂			46B-A00-50BM	450 < 24.3 >	460 < 24.9 >	470 < 25.4 >	450 < 24.3 >	
Rc2	Rc2		46B-B00-50BM	510 < 27.6 >	510 < 27.6 >	515 < 27.8 >	480 < 25.9 >	11.5
Rc2			46B-C00-50BM	510 < 27.6 >	510 < 27.6 >	540 < 29.2 >	500 < 27.0 >	

HOW TO ORDER

46 8 - 4 0 0 - 3 0 B M



4 PORT MASTER VALVE, 460 SERIES

③ Basic Body Size

3	3/8" Body
8	1" Body
B	1 1/2" Body

④ Pipe Size

2	Rc ¹ / ₄
3	Rc ³ / ₈
4	Rc ¹ / ₂
6	Rc ³ / ₄
8	Rc1
A	Rc1 ¹ / ₄
B	Rc1 ¹ / ₂
C	Rc2

⑦ Function

3	Closed Center
4	Exhaust Center
5	Pressure Center

⑧ Type of Operation

0	Air Pilot (Master Valve)
---	--------------------------

⑨ Accessory

B	With Mounting Bracket (Std.)
---	------------------------------

⑩ Operator

M	Air Pilot, Spring return
---	--------------------------

DIMENSIONS

—mm—

460 Series, 3-Position Master Valve, Closed Center

310-096-1

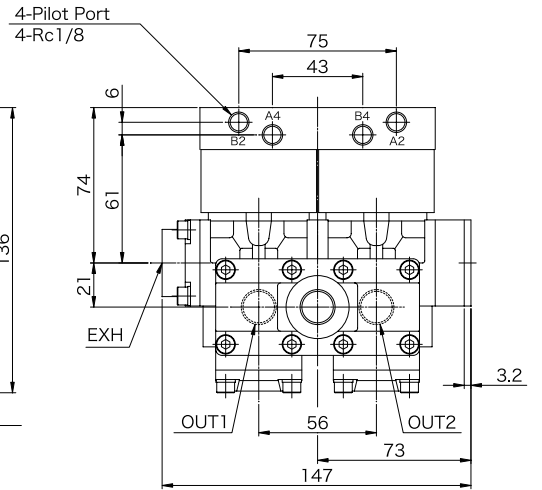
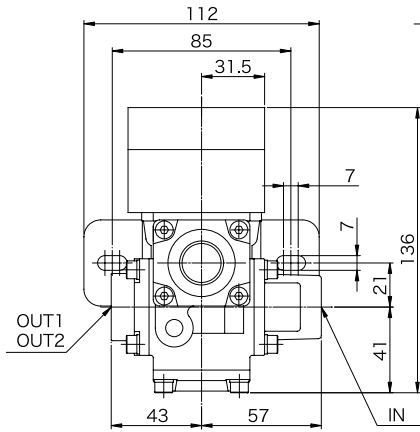
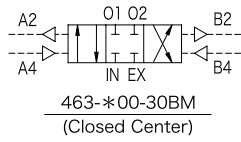

Port Sizes of Each Model

Model Numbers	IN & OUT	EXH
463-200-30BM	Rc1/4	Rc1/2
463-300-30BM	Rc3/8	
463-400-30BM	Rc1/2	

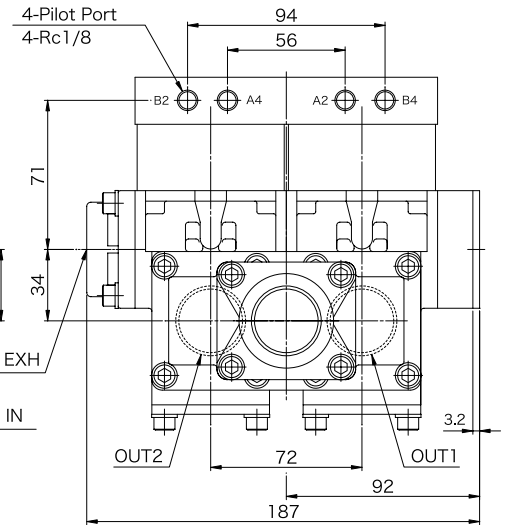
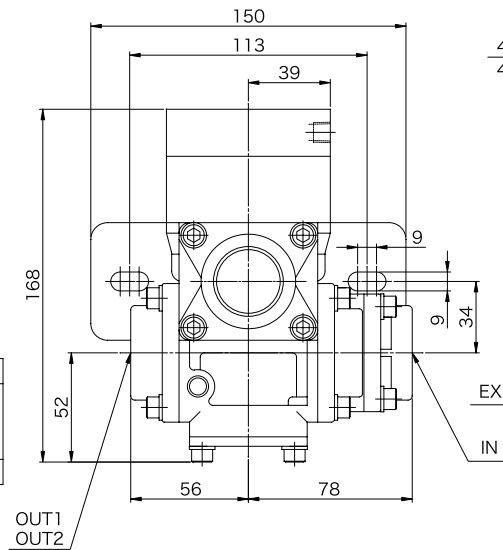
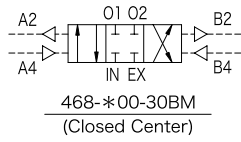

Port Sizes of Each Model

Model Numbers	IN & OUT	EXH
468-400-30BM	Rc1/2	Rc1
468-600-30BM	Rc3/4	
468-800-30BM	Rc1	
468-A00-30BM	Rc1-1/4	

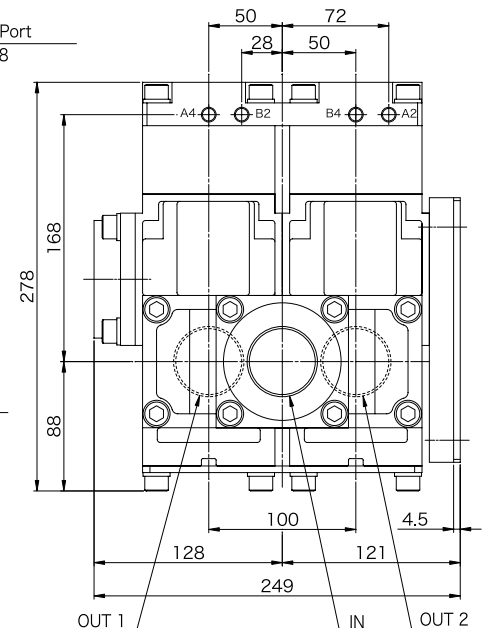
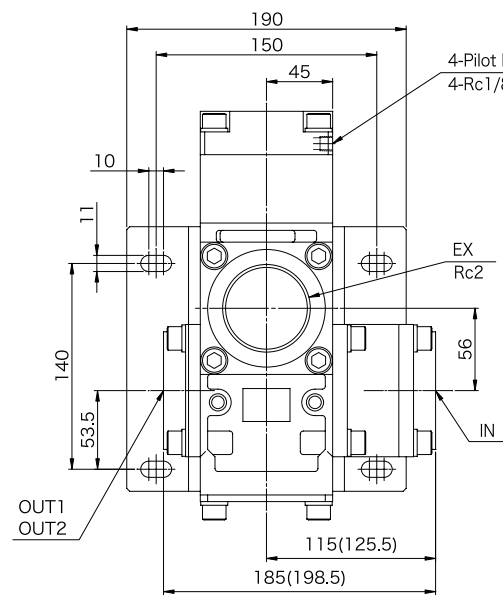
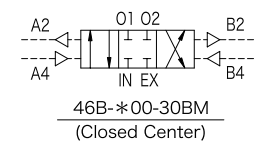

Port Sizes of Each Model

Model Numbers	IN & OUT	EXH
46B-A00-30BM	Rc1-1/4	Rc2
46B-B00-30BM	Rc1-1/2	
46B-C00-30BM	Rc2	

Dimensions in () are for 46B-C00-*0B0

(CAD data of 46B was modified by x0.7 for fitting indication)

(By Dwg 3J-7227, -7229, -7228A)

DIMENSIONS

—mm—

460 Series, 3-Position Master Valve, Exhaust/Pressure Center

310-096-2

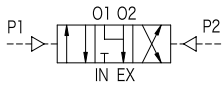

463-∗00-40BM
(Exhaust Center)

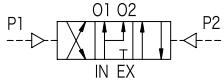

463-∗00-50BM
(Pressure Center)

Port Sizes of Each Model

Model Numbers	IN & OUT	EXH
463-200-40BM/50BM	Rc1/4	Rc1/2
463-300-40BM/50BM	Rc3/8	
463-400-40BM/50BM	Rc1/2	

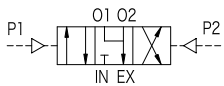
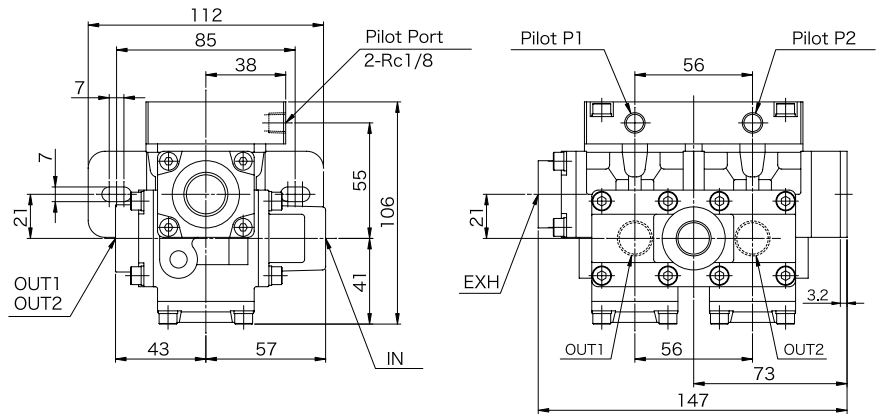

468-∗00-40BM
(Exhaust Center)

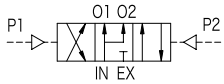

468-∗00-50BM
(Pressure Center)

Port Sizes of Each Model

Model Numbers	IN & OUT	EX
468-400-40BM/50BM	Rc1/2	Rc1
468-600-40BM/50BM	Rc3/4	
468-800-40BM/50BM	Rc1	
468-A00-40BM/50BM	Rc1-1/4	

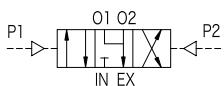
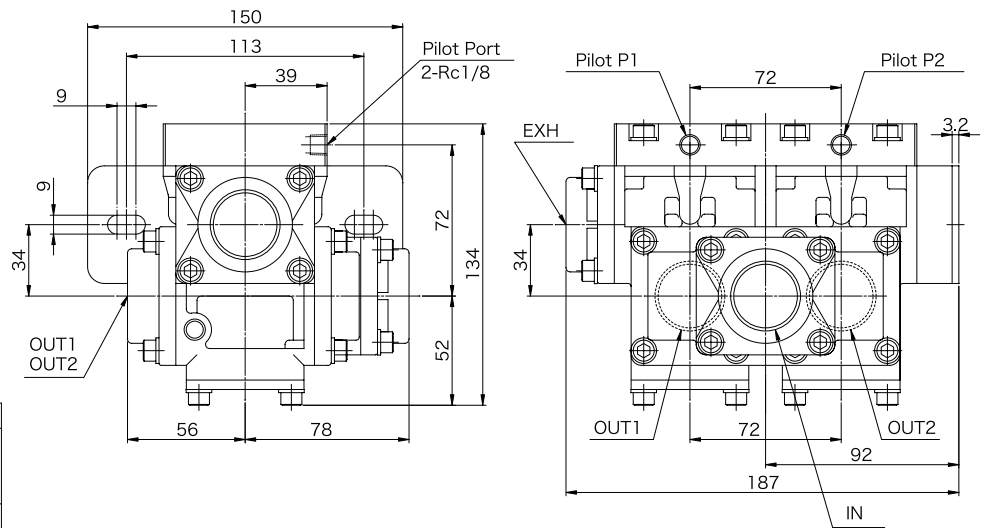

46B-∗00-40BM
(Exhaust Center)

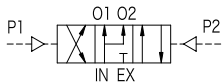

46B-∗00-50BM
(Pressure Center)

Port Sizes of Each Model

Model Numbers	IN & OUT	EX
46B-A00-40BM/50BM	Rc1-1/4	Rc2
46B-B00-40BM/50BM	Rc1-1/2	
46B-C00-40BM/50BM	Rc2	

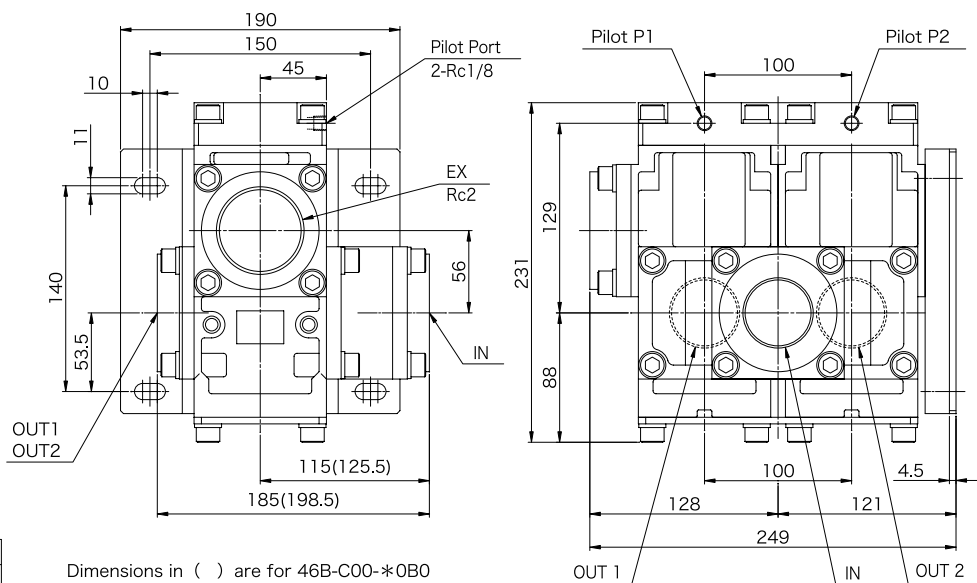

Dimensions in () are for 46B-C00-∗0B0

(CAD data of 46B was modified by x0.7 for fitting indication)

(By Dwg 3J-7224, -7225A, -7226A)

3 PORT MASTER VALVE

360 Super Poppet SERIES (Rc¹/₄~Rc2)

IN-LINE TYPE

Poppet valve



SPECIFICATIONS

FLUID	Filtered Compressed Air		
OPERATING PRESSURE	0.05 ~ 1.0MPa		
	Main pressure range	0.05 ~ 0.15MPa	0.15 ~ 1.0MPa
	Pilot pressure range	0.15 ~ 0.3MPa	Same to pressure of main valve or higher.
AMBIENT TEMPERATURE	5 ~ 60°C		
PROOF PRESSURE	1.6MPa		
LUBRICANTS	ISO VG32 turbine oil, or equivalent oil is recommended.		

* When the pilot pressure is higher than the pressure supplied to the main valve, the differential pressure should be less than 0.3MPa.

* Pilot pressure must not exceed 1.0MPa.

BASIC MODEL NOS. & OTHERS

Port Size		MODEL NUMBER		Effective Area [mm ²] < Cv value >				Mass [kg]
		Single Pilot Normally Closed	Single Pilot Normally Open	IN-OUT		OUT-EX		
IN-OUT	EX			NC	NO	NC	NO	
Rc ¹ / ₄	Rc ¹ / ₂	363-200-00BM	363-200-10BM	42.5<2.3>	47.5<2.6>	56< 3.0>	56< 3.0>	0.7
Rc ³ / ₈		363-300-00BM	363-300-10BM	63< 3.4>	60< 3.2>	85< 4.6>	71< 3.8>	
Rc ¹ / ₂		363-400-00BM	363-400-10BM	75< 4.1>	63< 3.4>	100< 5.4>	71< 3.8>	
Rc ¹ / ₂	Rc1	368-400-00BM	368-400-10BM	106< 5.7>	112< 6.1>	160< 8.6>	140< 7.6>	1.4
Rc ³ / ₄		368-600-00BM	368-600-10BM	170< 9.2>	150< 8.1>	236<12.8>	176< 9.5>	
Rc1		368-800-00BM	368-800-10BM	190<10.3>	190<10.3>	250<13.5>	180< 9.7>	
Rc1 ¹ / ₄	Rc1 ¹ / ₄	368-A00-00BM	368-A00-10BM	190<10.3>	190<10.3>	250<13.5>	180< 9.7>	5.6
Rc1 ¹ / ₄	Rc2	36B-A00-00BM	36B-A00-10BM	450<24.3>	400<21.6>	530<28.6>	425<23.0>	
Rc1 ¹ / ₂		36B-B00-00BM	36B-B00-10BM	500<27.0>	480<25.9>	600<32.4>	500<27.0>	
Rc2		36B-C00-00BM	36B-C00-10BM	530<28.6>	480<25.9>	600<32.4>	500<27.0>	

HOW TO ORDER

36 8 - 8 0 0 - 0 0 B M

③ ④ ⑦ ⑧ ⑨ ⑩

360 SERIES
3-PORT MASTER VALVE

③ Basic Body Size

3 | ³/₈" Body
8 | 1" Body
B | 1¹/₂" Body

④ Pipe Size

2 | Rc¹/₄
3 | Rc³/₈
4 | Rc¹/₂
6 | Rc³/₄
8 | Rc1
A | Rc1¹/₄
B | Rc1¹/₂
C | Rc2

⑦ Function

0 | Single pilot, Normally closed
1 | Single pilot, Normally open

⑧ Type of Operation

0 | Air pilot (Master valve)

⑨ Accessory

B | With Mounting Bracket (Std.)

⑩ Operator

M | Air pilot Spring return

DIMENSIONS

—mm—

360 Series 3-Port Master Valve, 2-Position

310-097-1

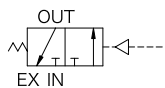

363-*00-00BM
(Normally Closed)

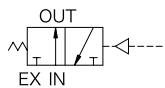

363-*00-10BM
(Normally Open)

Port Sizes of Each Model

Model Numbers	IN & OUT	EX
363-200-*0BM	Rc1/4	Rc1/2
363-300-*0BM	Rc3/8	
363-400-*0BM	Rc1/2	

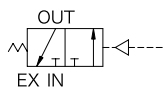
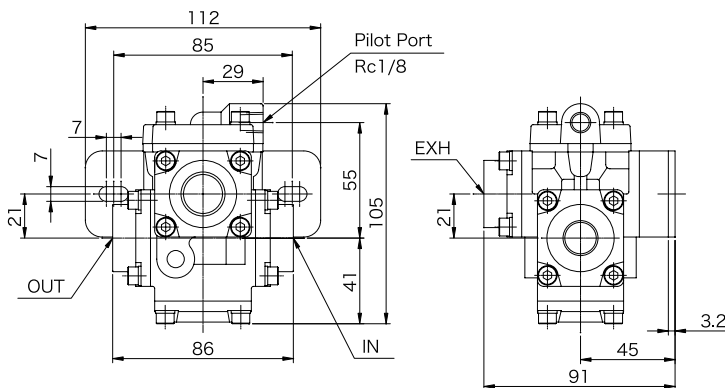

368-*00-00BM
(Normally Closed)

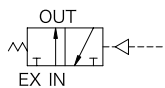

368-*00-10BM
(Normally Open)

Port Sizes of Each Model

Model Numbers	IN & OUT	EX
368-400-*0BM	Rc1/2	Rc1
368-600-*0BM	Rc3/4	
368-800-*0BM	Rc1	
368-A01-*0BM	Rc1-1/4	Rc1-1/4

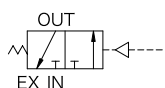
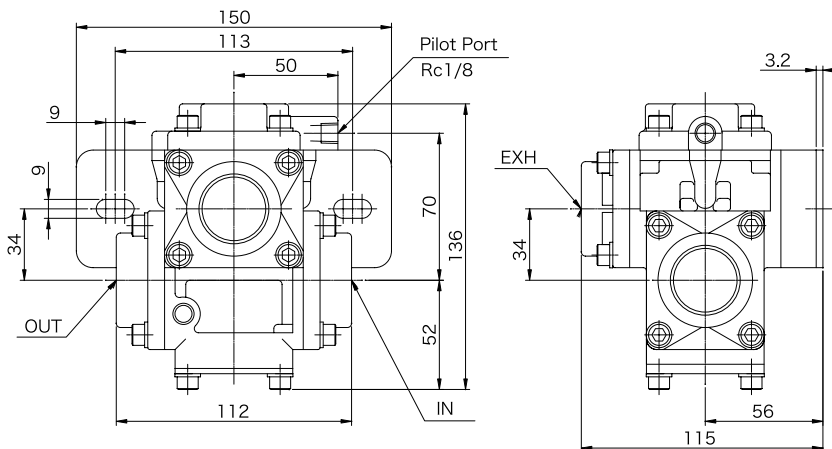

36B-*00-00BM
(Normally Closed)

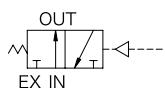

36B-*00-10BM
(Normally Open)

Port Sizes of Each Model

Model Numbers	IN & OUT	EX
36B-A00-*0BM	Rc1-1/4	Rc2
36B-B00-*0BM	Rc1-1/2	
36B-C00-*0BM	Rc2	

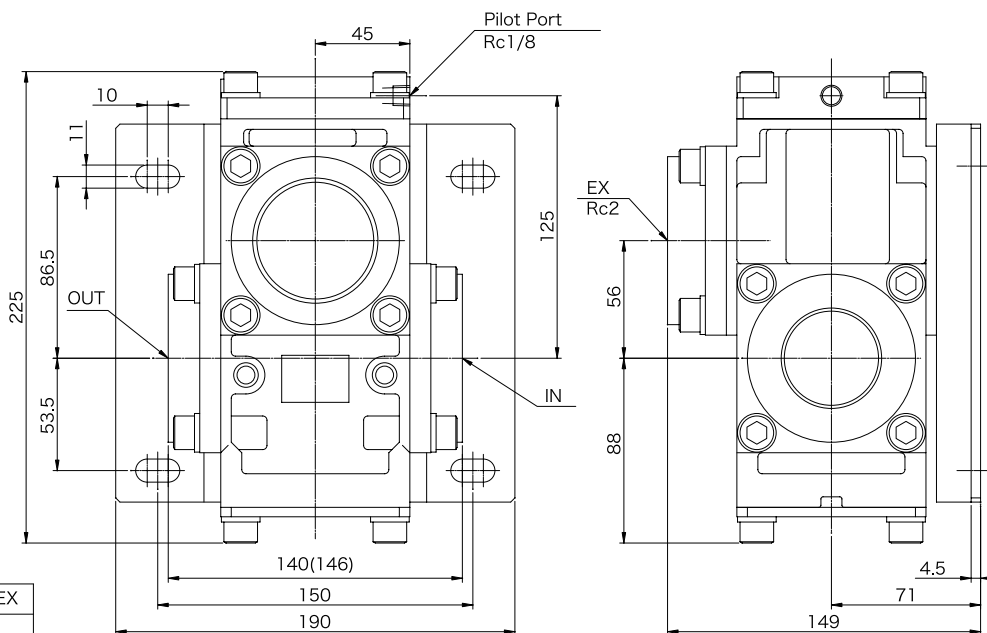

Dimensions in () are for 36B-C00-*0BM. (Rc2 size)

3 PORT MASTER VALVE

360 Super Poppet SERIES (Rc¹/₄~Rc¹/₂)

HI-LOW PRESSURE CHANGE

Poppet valve

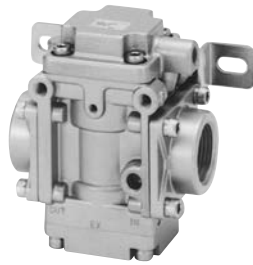

SPECIFICATIONS

FLUID		Filtered Compressed Air
SERVICING PRESSURE	Master valve pressure range*	Higher Pressure side (IN) 0.05 ~ 1.0MPa
		Lower Pressure side (EX) 0 ~ 0.85MPa
	Pilot air pressure setting of pilot air pressure*	P = Higher pressure side (IN) + 0 ~ 0.2MPa
		P = Lower pressure side (EX) + 0.15MPa
AMBIENT TEMPERATURE		5 ~ 60°C
PROOF PRESSURE		1.6MPa
LUBRICANTS		ISO VG32 turbine oil, or equivalent oil is recommended.

* High side pressure (=IN PORT), Lower side pressure (=EX PORT)

* Pilot air pressure must be lower than 1.0MPa (=10kgf/cm²).

BASIC MODEL NOS. & OTHER SPECIFICATIONS

Pipe Size	MODEL NUMBER 2 Position Single Pilot	Effective Area [mm ²] < Cv value >		Mass [kg]
		IN-OUT	OUT-EX	
	Rc ¹ / ₄	363-200-80BM	44< 2.4>	
Rc ³ / ₈	363-300-80BM	53< 2.8>	50< 2.7>	
Rc ¹ / ₂	363-400-80BM	55< 3.0>	60< 3.2>	
Rc ¹ / ₂	368-400-80BM	125< 6.8>	135< 7.3>	1.6
Rc ³ / ₄	368-600-80BM	180< 9.7>	170< 9.2>	
Rc1	368-800-80BM	195<10.5>	180< 9.7>	
Rc1 ¹ / ₄	368-A00-80BM	200<10.8>	180< 9.7>	
Rc1 ¹ / ₄	36B-A00-80BM	410<22.2>	386<20.9>	5.8
Rc1 ¹ / ₂	36B-B00-80BM	450<24.4>	407<22.0>	

HOW TO ORDER

368-600-80BM

③ ④ ⑦⑧⑨⑩

360 SERIES
3-PORT MASTER VALVE

③ Basic Body Size

3 | 3/8" Body
8 | 1" Body
B | 1 1/2" Body

④ Pipe Size

2 | Rc¹/₄
3 | Rc³/₈
4 | Rc¹/₂
6 | Rc³/₄
8 | Rc1
A | Rc1¹/₄
B | Rc1¹/₂

⑦ Function

8 | 2 Position, Single Pilot

⑧ Type of Operation

0 | Air pilot
(Master valve)

⑨ Accessory

B | With Mounting Bracket (Std.)

⑩ Operator

M | Air operated spring return

DIMENSIONS

—mm—

360 Series High/Low Press. Change Master Valve

310-097-2

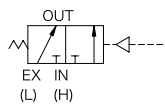

368-∗00-80BM
(High-Low Press. Change)

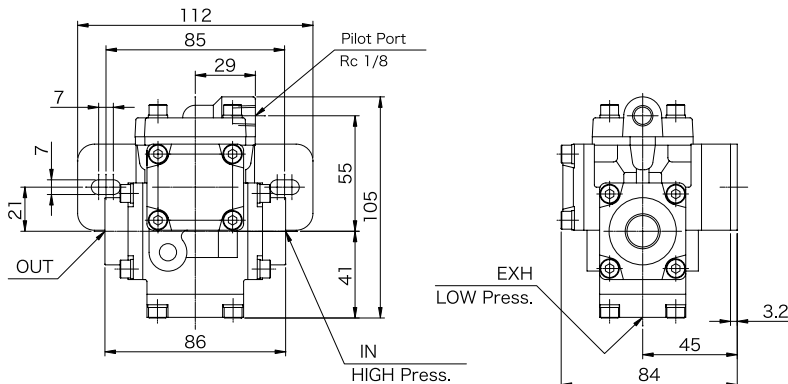

Port Sizes of Each Model

Model Numbers	IN, OUT & EX
363-200-80BM	Rc1/4
363-300-80BM	Rc3/8
363-400-80BM	Rc1/2

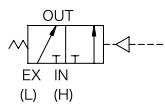

368-∗00-80BM
(High-Low Press. Change)

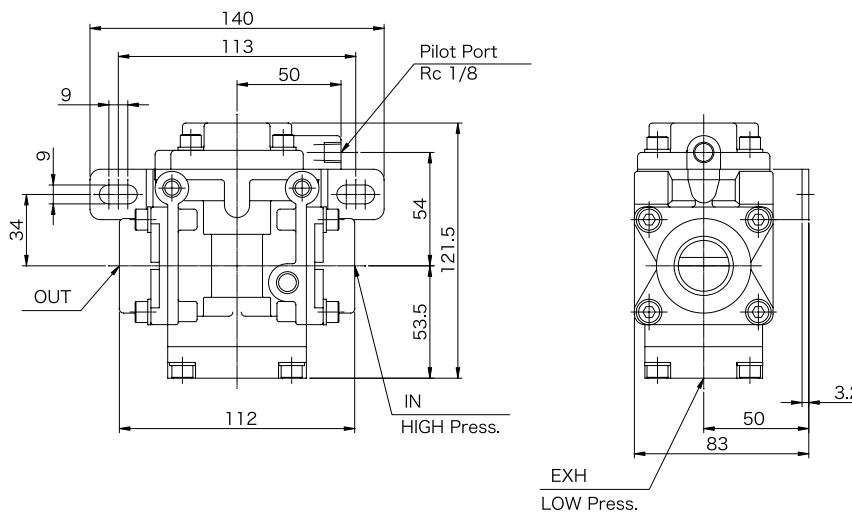

Port Sizes of Each Model

Model Numbers	IN, OUT & EX
368-400-80BM	Rc1/2
368-600-80BM	Rc3/4
368-800-80BM	Rc1
368-A00-80BM	Rc1-1/4

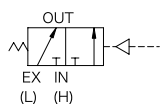

36B-∗00-80BM
(High-Low Press. Change)

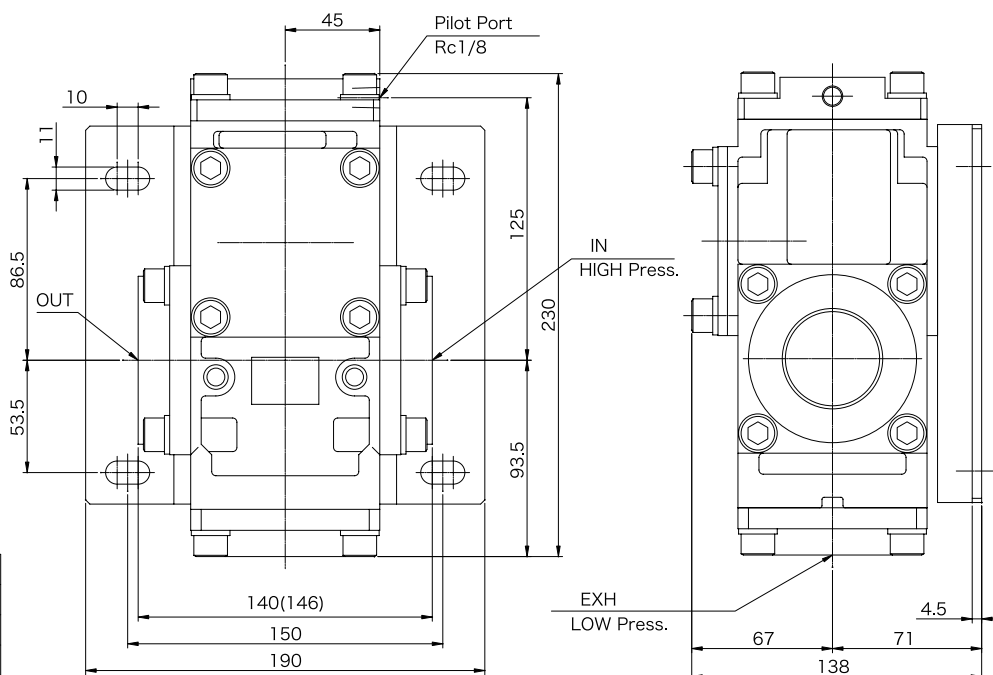

Port Sizes of Each Model

Model Numbers	IN, OUT & EX
36B-A00-80BM	Rc1-1/4
36B-B00-80BM	Rc1-1/2
36B-C00-80BM	Rc2

Dimensions in () are for 36B-B00-80BM, (Rc2 size).

3 PORT MASTER VALVE

392 SERIES (Rc¹/₄, Rc³/₈)

FOR COMPRESSED AIR & VACUUM
IN-LINE TYPE

poppet valve



Mounting bracket is attached as standard item.

SPECIFICATIONS

FLUID	Filtered Compressed Air	Vacuum
OPERATING PRESSURE RANGE	0 ~ 0.7MPa	-0.1 ~ -0.01MPa
	Main pressure range	0 ~ 0.7MPa
	Pilot pressure range	0.1MPa*
AMBIENT TEMPERATURE	5 ~ 60°C	
LUBRICATION	Not required	

* The valve will operate even at the pilot pressure of the same as that of the main valve. But, the minimum pilot pressure should be 0.1MPa.

MODEL NOS. & OTHER SPECIFICATIONS

Pipe Size	MODEL NUMBER		Effective Area (mm ²) < Cv value >	Mass (kg)
	for Compressed Air	for Vacuum		
Rc ¹ / ₄	392-200-60BM	392-200-02BM	11 < 0.6 >	0.15
Rc ³ / ₈	392-300-60BM	392-300-02BM		

HOW TO ORDER

392 - 200 - 60BM

④ ⑦ ⑨ ⑩

④ Pipe Size

2 Rc¹/₄
3 Rc³/₈

⑨ Accessory

B with Bracket (Std.)

⑦ Function

60 Universal Port type
02 Normal Closed, 2 Position For Vacuum

⑩ Operator

M Air Pilot — Spring Return

PRODUCT TYPE: 390 SERIES

DIMENSIONS

—mm—

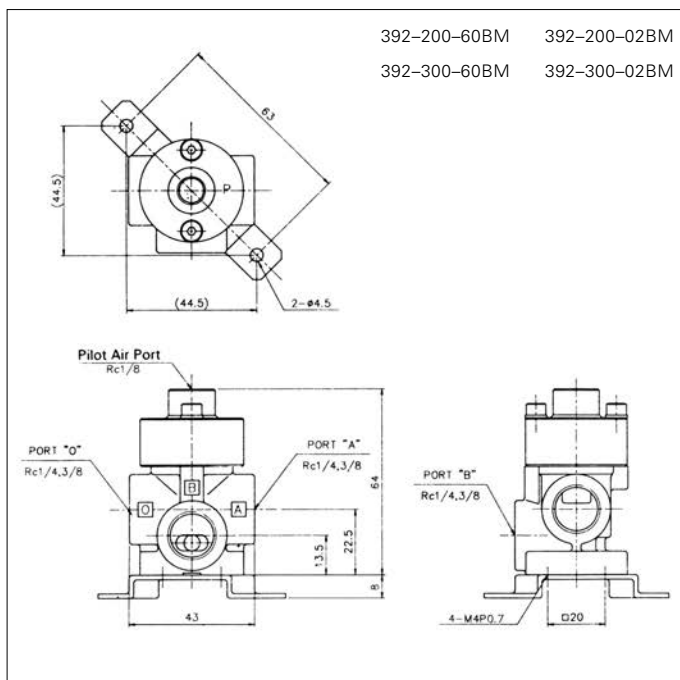

392-200-60BM 392-200-02BM
392-300-60BM 392-300-02BM

○ for Compressed Air Service Universal Ported ○ for Vacuum Service

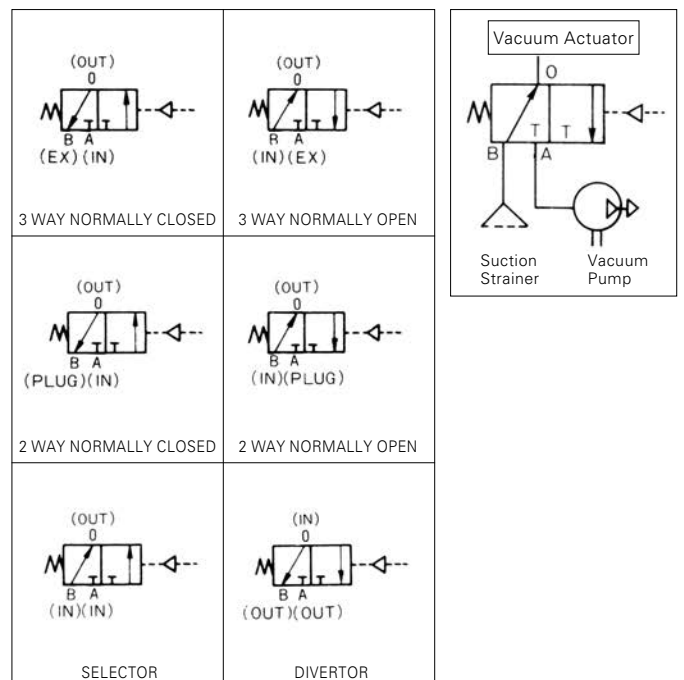

At installation, take care not to close vent hole at bottom side.

2 PORT MASTER VALVE

260 Super Poppet SERIES (Rc¹/₄~Rc2)

IN-LINE TYPE

Poppet valve



SPECIFICATIONS

FLUID	Filtered Compressed Air		
OPERATING PRESSURE	0.05 ~ 1.0MPa		
	Main pressure range	0.05 ~ 0.15MPa	0.15 ~ 1.0MPa
	Pilot pressure range	0.15 ~ 0.3MPa	Same to pressure of main valve or higher.
AMBIENT TEMPERATURE	5 ~ 60°C		
PROOF PRESSURE	1.6MPa		
LUBRICANTS	ISO VG32 turbine oil, or equivalent oil is recommended.		

* When the pilot pressure is higher than the pressure supplied to the main valve, the differential pressure should be less than 0.3MPa.

* Pilot pressure must not exceed 1.0MPa.

BASIC MODEL NOS. & OTHER SPECIFICATIONS

Pipe Size	MODEL NUMBER		Effective Area [mm ²] < Cv value >		Mass [kg]
	Single Pilot Normally Closed	Single Pilot Normally Open	Normally Closed	Normally Open	
	IN-OUT				
Rc ¹ / ₄	263-200-00BM	263-200-10BM	40< 2.2>	40< 2.2>	0.7
Rc ³ / ₈	263-300-00BM	263-300-10BM	58< 3.1>	53< 2.9>	
Rc ¹ / ₂	263-400-00BM	263-400-10BM	71< 3.8>	63< 3.4>	
Rc ¹ / ₂	268-400-00BM	268-400-10BM	112< 6.1>	112< 6.1>	1.4
Rc ³ / ₄	268-600-00BM	268-600-10BM	170< 9.2>	165< 8.9>	
Rc1	268-800-00BM	268-800-10BM	190<10.2>	190<10.2>	
Rc1 ¹ / ₄	268-A00-00BM	268-A00-10BM	190<10.2>	190<10.2>	5.6
Rc1 ¹ / ₄	26B-A00-00BM	26B-A00-10BM	450<24.3>	480<25.9>	
Rc1 ¹ / ₂	26B-B00-00BM	26B-B00-10BM	510<27.5>	550<29.7>	
Rc2	26B-C00-00BM	26B-C00-10BM	570<30.8>	600<32.4>	

HOW TO ORDER

268-600-00BM

③ ④ ⑦ ⑧ ⑨ ⑩

260 SERIES
2-PORT MASTER VALVE

③ Basic Body Size

- 3 | 3/8" Body
- 8 | 1" Body
- B | 1 1/2" Body

④ Pipe Size

- 2 | Rc¹/₄
- 3 | Rc³/₈
- 4 | Rc¹/₂
- 6 | Rc³/₄
- 8 | Rc1
- A | Rc1¹/₄
- B | Rc1¹/₂
- C | Rc2

⑦ Function

- 0 | Normally closed
- 1 | Normally open

⑧ Type of Operation

- 0 | Air pilot (Master valve)

⑨ Accessory

- B | With Mounting Bracket (Std.)

⑩ Operator

- M | Air pilot Master valve

DIMENSIONS

—mm—

260 Series 2-Port Master Valve, 2-Position

310-097-3

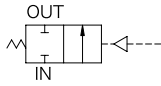

263-*00-00BM
(Normally Closed)

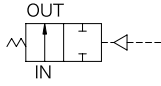

263-*00-10BM
(Normally Open)

Port Sizes of Each Model

Model Numbers	IN, OUT
263-200-00BM/10BM	Rc1/4
263-300-00BM/10BM	Rc3/8
263-400-00BM/10BM	Rc1/2

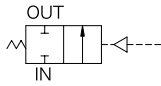
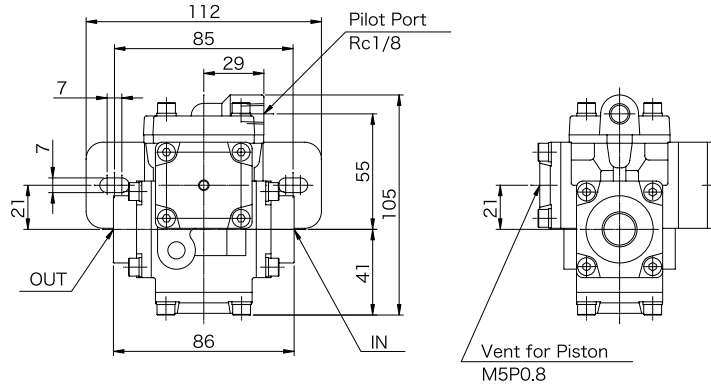

268-*00-00BM
(Normally Closed)

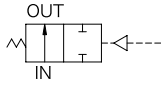

268-*00-10BM
(Normally Open)

Port Sizes of Each Model

Model Numbers	IN, OUT
268-400-00BM/10BM	Rc1/2
268-600-00BM/10BM	Rc3/4
268-800-00BM/10BM	Rc1
268-A00-00BM/10BM	Rc1-1/4

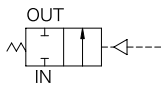
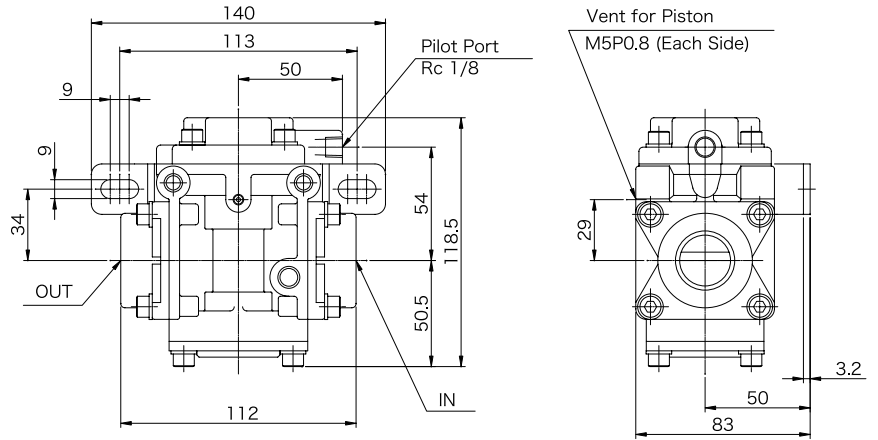

268-*00-00BM
(Normally Closed)

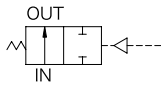

268-*00-10BM
(Normally Open)

Port Sizes of Each Model

Model Numbers	IN, OUT
26B-A00-00BM/10BM	Rc1-1/4
26B-B00-00BM/10BM	Rc1-1/2
26B-C00-00BM/10BM	Rc2

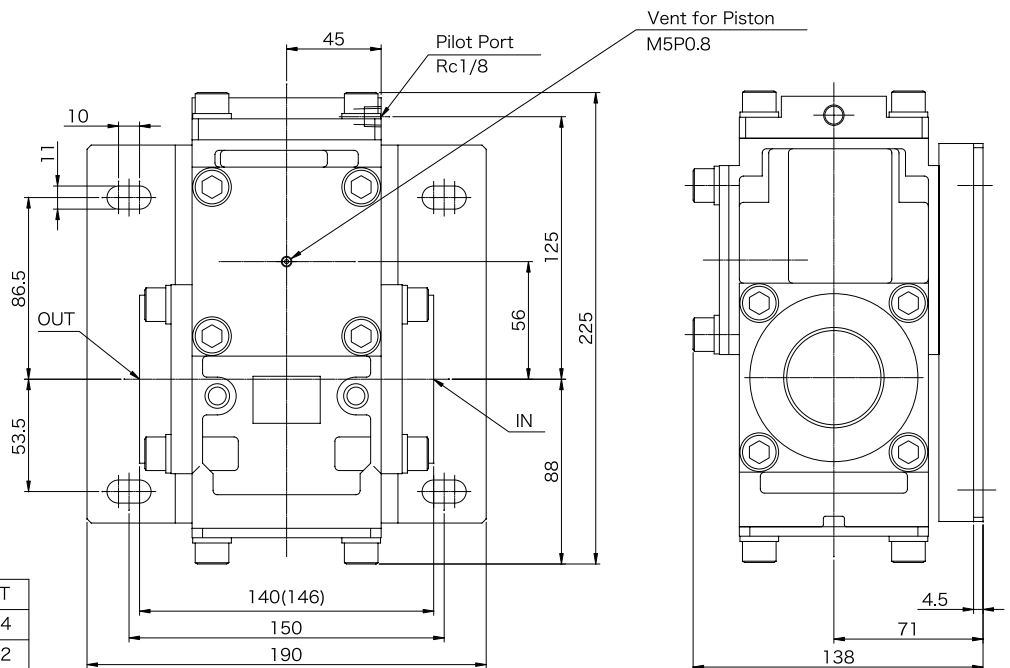

Dimensions in () are for 36B-B00-80BM, (Rc2 size).

5 PORT/3 PORT PILOT VALVE

POV-4000/3000 SERIES (Rc¹/₄)



"RA"



"G"



"YSLP"

SPECIFICATIONS

FLUID	Filtered Compressed Air
OPERATING PRESSURE	0 ~ 1.0MPa
AMBIENT TEMPERATURE	5 ~ 60°C
LUBRICANTS	ISO VG32 turbine oil, or equivalent oil is recommended.

MODEL NOS. & OTHERS

OPERATOR		Port	Pipe Size	MODEL NUMBER	Effective Area [mm ²] < Cv value >	min. Shift Force/Pressure	min. Shift Stroke (mm)	Over ride (mm)	Mass [kg]	
MECHANICALLY OPERATED	Roller type	5	Rc ¹ / ₄	POV-4002RA	8.8 < 0.48 >	32N (3.2kgf)	5	1.5	0.4	
		3	Rc ¹ / ₄	POV-3002RA	9.4 < 0.51 >	55N (5.5kgf)	5	1.5	0.3	
	Lever type	5	Rc ¹ / ₄	POV-4002L	8.8 < 0.48 >	20N (2.0kgf)	10	3	0.45	
		3	Rc ¹ / ₄	POV-3002L	9.4 < 0.51 >	30N (3.0kgf)	10	3	0.35	
	Push rod type	5	Rc ¹ / ₄	POV-4002C	8.8 < 0.48 >	32N (3.2kgf)	5	1.5	0.4	
		3	Rc ¹ / ₄	POV-3002C	9.4 < 0.51 >	55N (5.5kgf)	5	1.5	0.3	
AIR PILOT OPERATED	Single pilot type	5	Rc ¹ / ₄	POV-4002G	8.8 < 0.48 >	0.1MPa (1kgf/cm ²)	—	—	1.0	
		3	Rc ¹ / ₄	POV-3002G	9.4 < 0.51 >	0.1Mpa (1kgf/cm ²)	—	—	0.7	
	Double pilot type	5	Rc ¹ / ₄	POV-4002D	8.8 < 0.48 >	0.08MPa (0.8kgf/cm ²)	—	—	1.1	
		3	Rc ¹ / ₄	POV-3002D	9.4 < 0.51 >	0.08MPa (0.8kgf/cm ²)	—	—	0.8	
MANUALLY OPERATED	Push button type	5	Rc ¹ / ₄	POV-4002YBP*	8.8 < 0.48 >	32N (3.2kgf)	5	1.5	0.45	
		3	Rc ¹ / ₄	POV-3002YBP*	9.4 < 0.51 >	55N (5.5kgf)	4	2.5	0.35	
	Palm button type	5	Rc ¹ / ₄	POV-4002YKP*	8.8 < 0.48 >	32N (3.2kgf)	5	1.5	0.45	
		3	Rc ¹ / ₄	POV-3002YKP*	9.4 < 0.51 >	55N (5.5kgf)	5	1.5	0.35	
	Knob Selector type	2 position	5	Rc ¹ / ₄	POV-4002YSP	8.8 < 0.48 >	Knob shift angle 90° (2 notch)	—	—	0.45
			3	Rc ¹ / ₄	POV-3002YSP	9.4 < 0.51 >		—	—	0.35
	Knob Selector type	3 position Closed Center	5	Rc ¹ / ₄	POV-4302YSP	8.8 < 0.48 >	to right/left shift angle 45° (3 notch)	—	—	0.45
		Lever Selector type	2 position	5	Rc ¹ / ₄	POV-4002YSLP	8.8 < 0.48 >	Lever shift angle 90° (2 notch)	—	—
	3			Rc ¹ / ₄	POV-3002YSLP	9.4 < 0.51 >	—		—	0.45
	Lever Selector type	3 position Closed Center	5	Rc ¹ / ₄	POV-4302YSLP	8.8 < 0.48 >	to right/left shift angle 45° (3 notch)	—	—	0.55
			Push button type (Lockable model)	5	Rc ¹ / ₄	POV-4002B	8.8 < 0.48 >	32N (3.2kgf)	5	1.5
	3	Rc ¹ / ₄		POV-3002B	9.4 < 0.51 >	55N (5.5kgf)	5	1.5	0.35	

*Specify button and/or knob colour by adding "X", "Y" and "Z", when selecting Push button and Palm button type pilot valve.
X : Black Y : Red Z : Green (Knob selector type : POV-*002YSP is black knob only.)

*Standard colour of each type

Push button : black (X)

Palm button : red (Y)

HOW TO ORDER

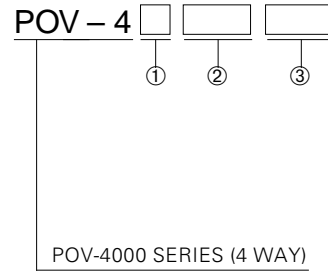
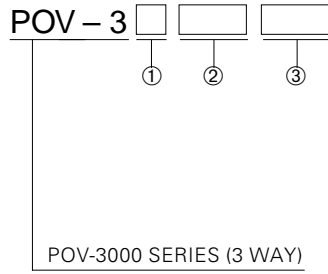

① Position

0	2 position
3	3 position closed center

② Pipe Size

02	Rc 1/4
----	--------

③ TYPE OF OPERATOR

B	Push Button (Lockable model)	
YBPX YBPY YBPZ	Black Button (Standard) Red Button Green Button	Push Button type
C	Push Rod type	Mechanical
D G	Double Pilot Single Pilot	Air Pilot type
YKPX YKPY YKPZ	Black Button Red Button (Standard) Green Button	Palm Button type
L	Lever type	Mechanical
RA RB	Roller (Standard) Roller (roller position rotated 90°)	Mechanical Roller type
YSLP YSLPE	Lever (Standard) Lever (selector position rotated 90°)	Lever Selector type
YSP	Black Knob (Standard)	Knob Selector type
YSPE	Black Knob (Standard) (selector position rotated 90°)	Knob Selector type

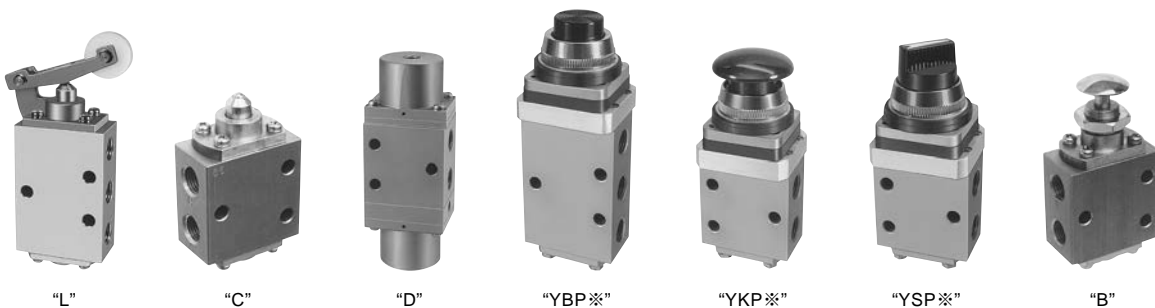

DIMENSIONS

—mm—

5-Port Pilot Valve

315-016-1

Roller Lever type

POV-4002RA/POV-4002RB

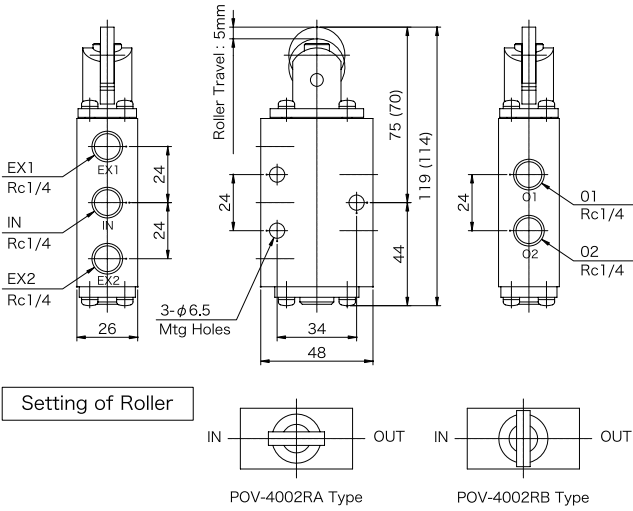
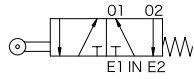

Roller Lever type

POV-4002L

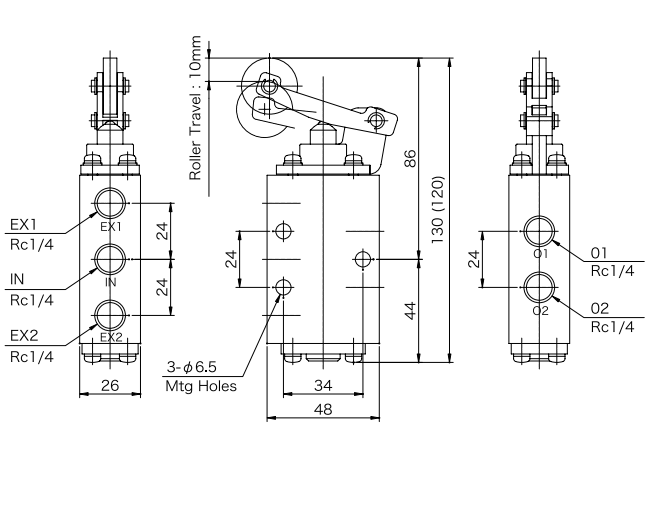
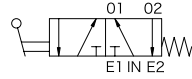

Plunger type

POV-4002C

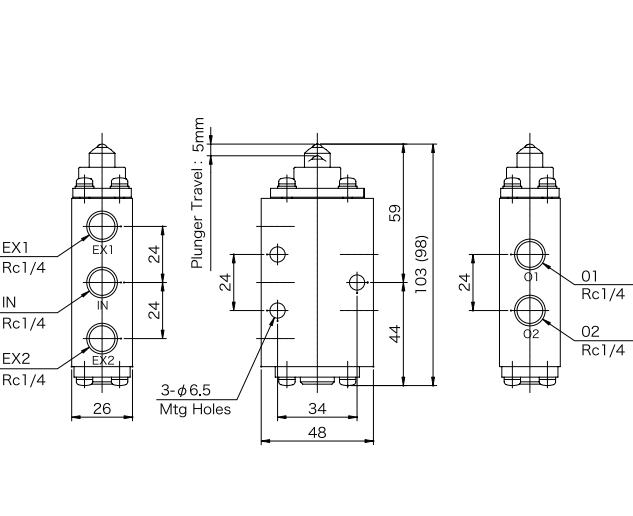
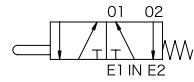

Push Button type - Lockable

POV-4002B

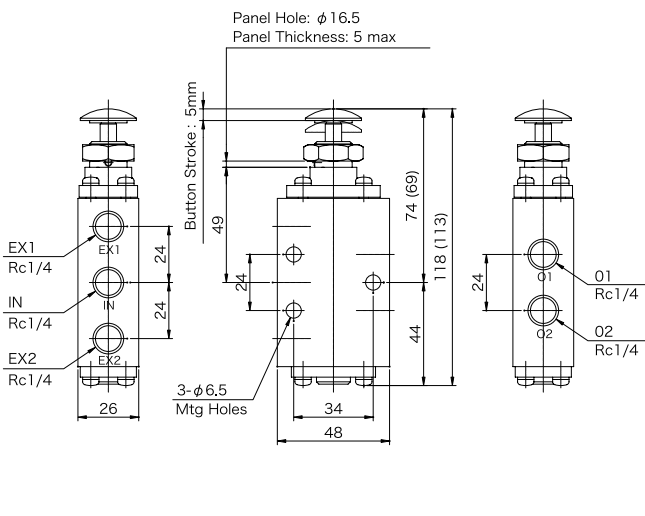
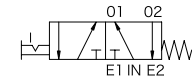

Single Pilot type

POV-4002G

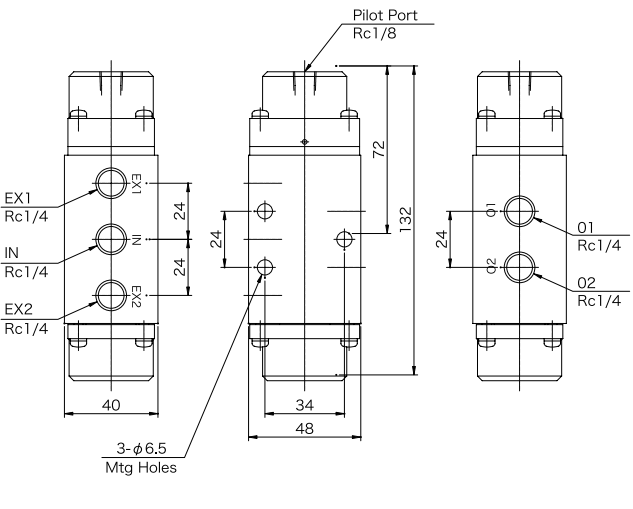
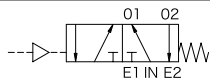

Double Pilot type

POV-4002D

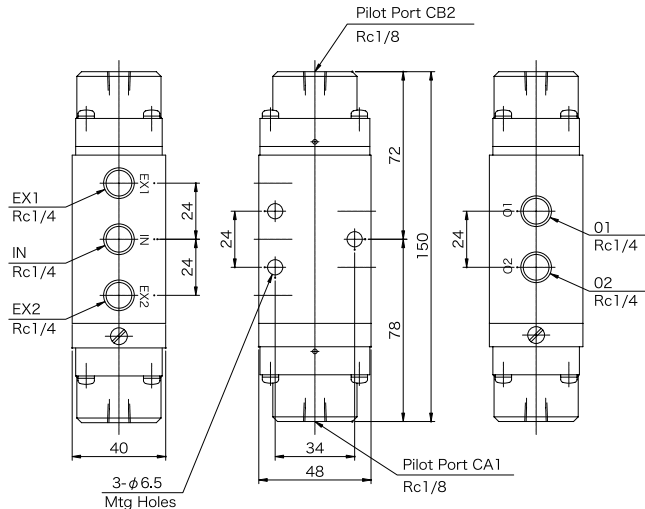
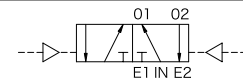

(By Dwg 3J-xxxx, -xxxx)

DIMENSIONS

—mm—

5-Port Pilot Valve

315-016-2

Push Button type

POV-4002YBP*

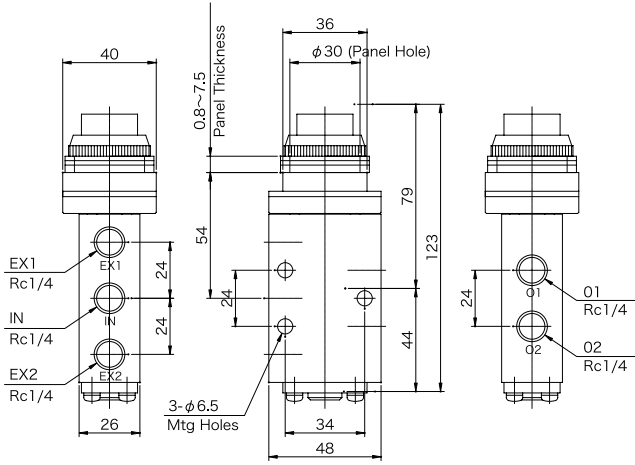
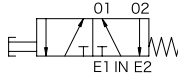

Palm Button type

POV-4002YKP*

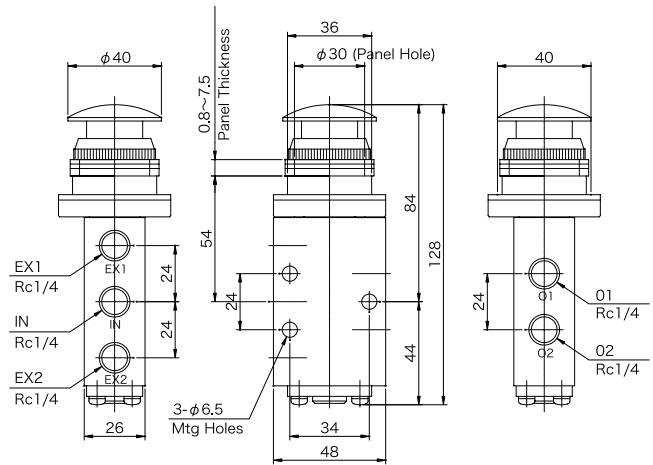
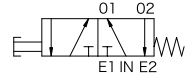

Knob Selector type

POV-4002YSP/POV-4002YSPE

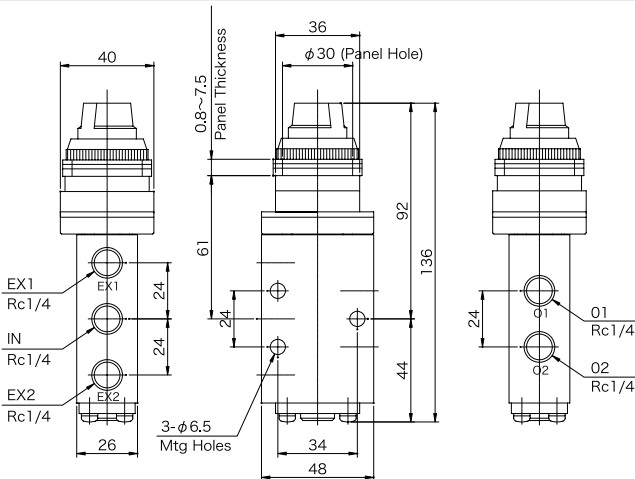
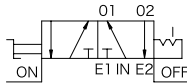

Knob Operation

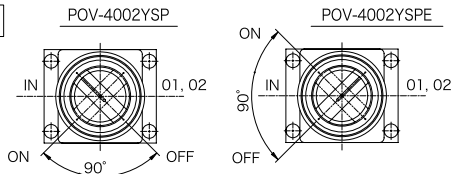

Lever Selector type

POV-4002YSLP/4002YSLPE

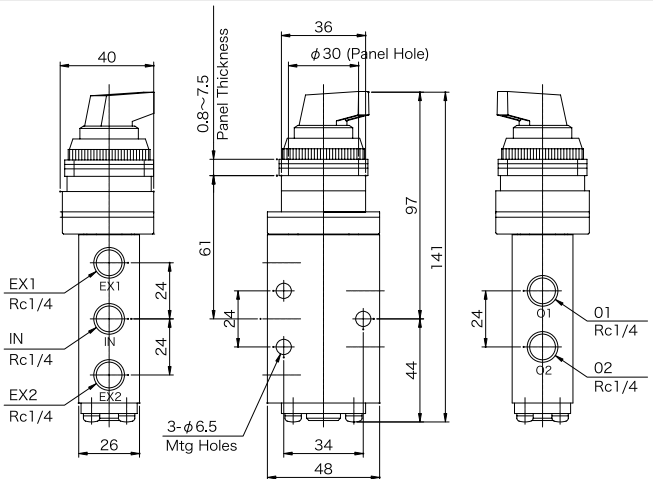
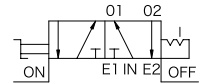

Lever Operation

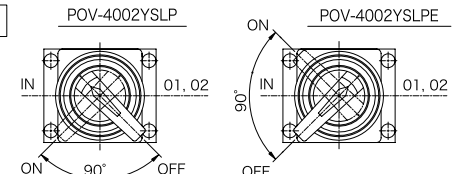

Knob/Lever Operation of 3-Position type

	POV-4302YSP POV-4302YSPE
	POV-4402YSP POV-4402YSPE
	POV-4502YSP POV-4502YSPE

NOTE: Dimensions of 3-position types are common with those of 2-position POV-4002YSP(E) and POV-4002YSLP(E).

Knob Operation

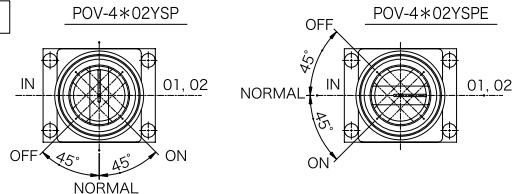

Lever Operation

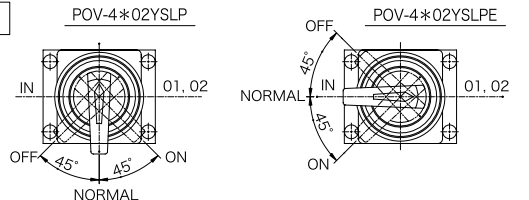

DIMENSIONS

—mm—

3-Port Pilot Valve

315-016-3

Roller Lever type

POV-3002RA/POV-3002RB

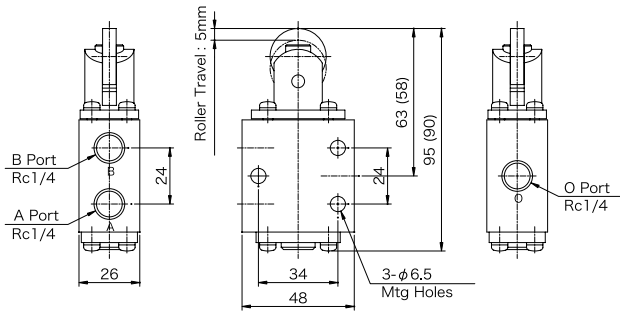
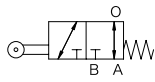

Setting of Roller

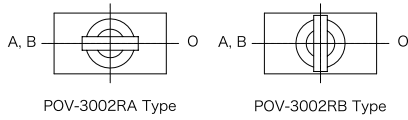

Roller Lever type

POV-3002L

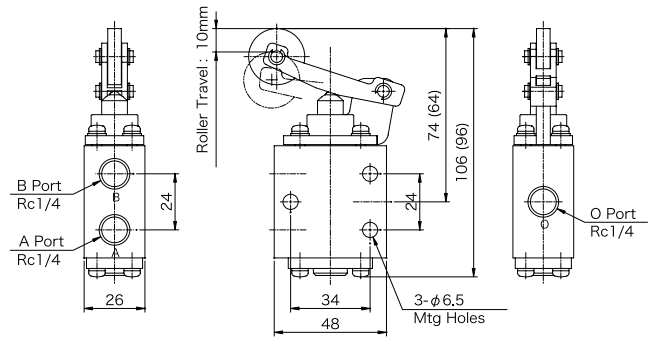
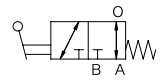

Plunger type

POV-3002C

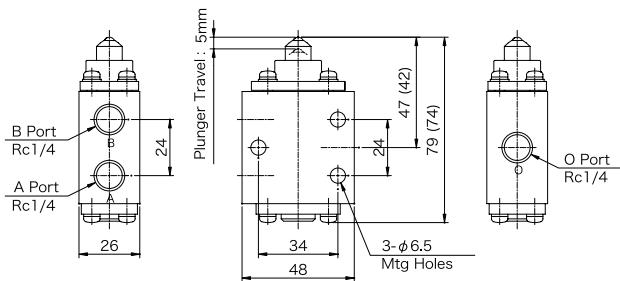
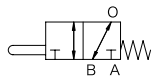

Push Button type - Lockable

POV-3002B

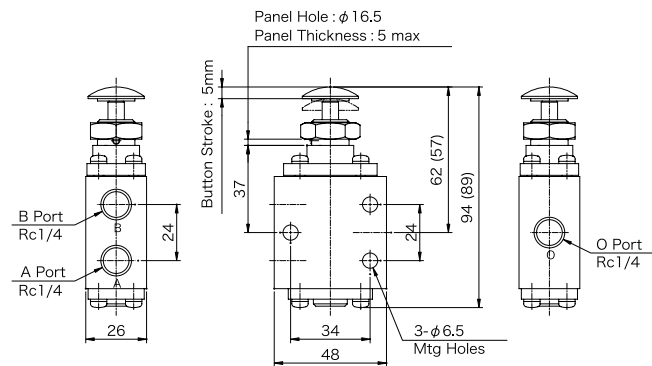
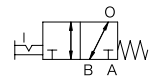

Single Pilot type

POV-3002G

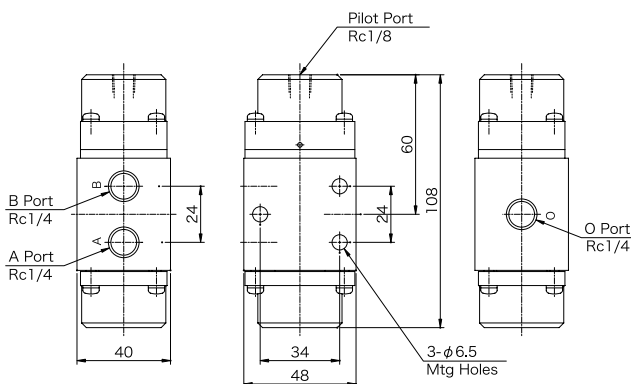
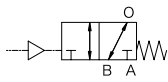

Double Pilot type

POV-3002D

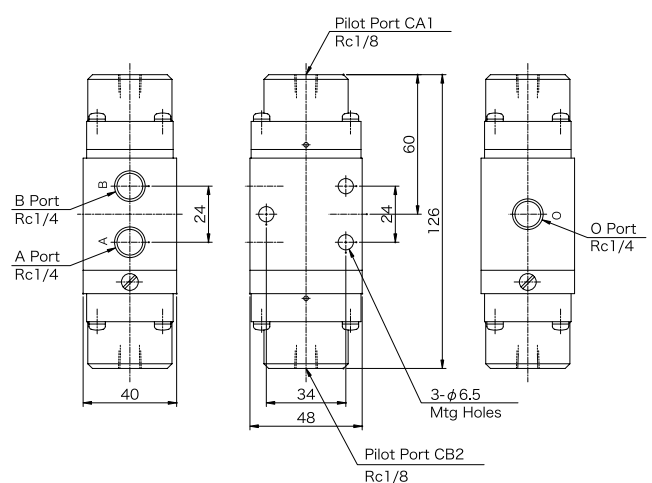
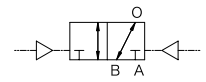

DIMENSIONS

—mm—

3-Port Pilot Valve

315-016-4

Push Button type

POV-3002YBP*

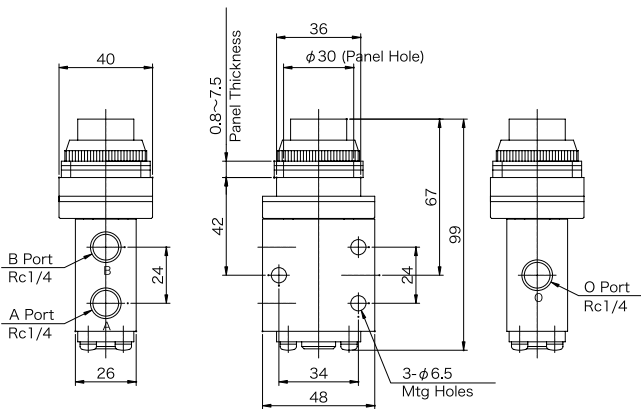
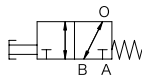

Palm Button type

POV-3002YKP*

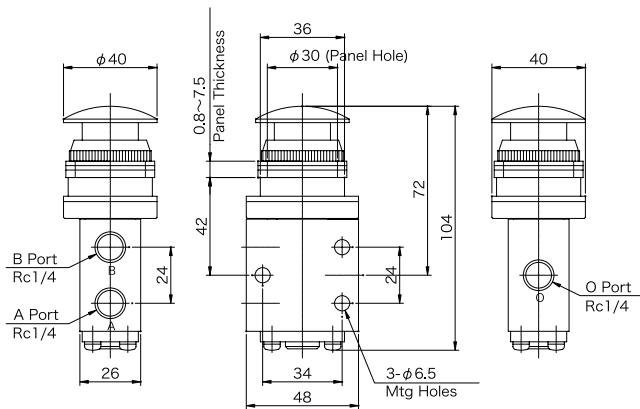
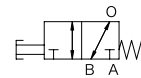

Knob Selector type

POV-3002YSP/POV-3002YSPE

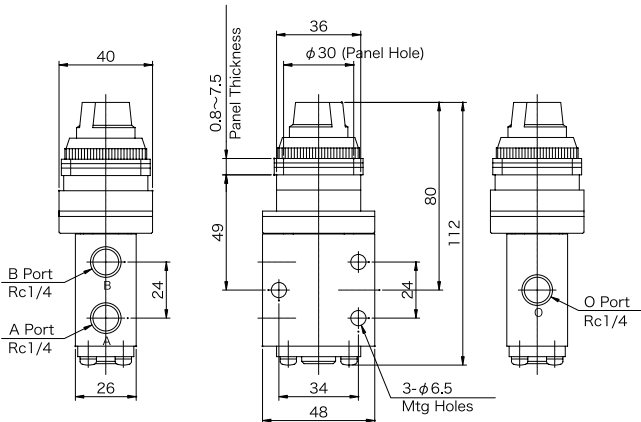
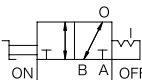

Knob Operation

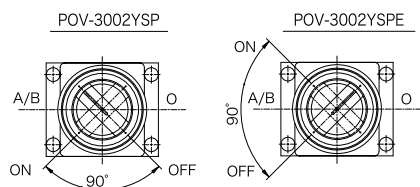

Lever Selector type

POV-3002YSLP/3002YSLPE

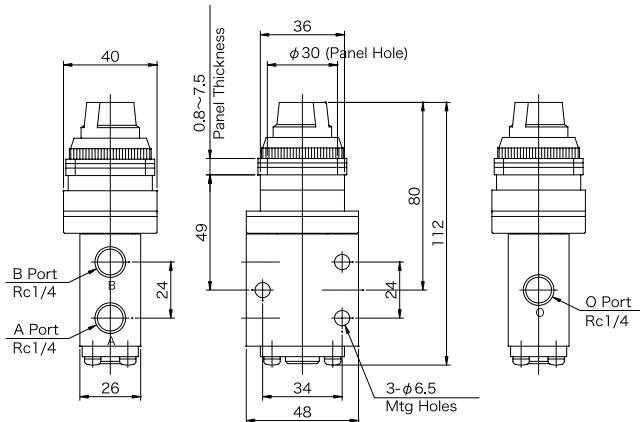
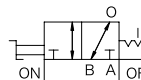

Lever Operation

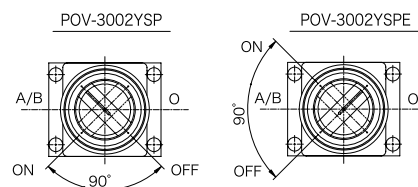

4 PORT HAND VALVE

DV-4100 SERIES (Rc¹/₄~Rc1)

3 position poppet valve

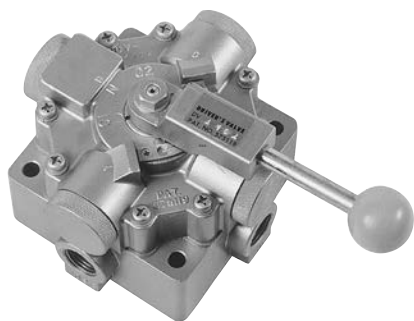

SPECIFICATIONS

FLUID	Filtered Compressed Air
OPERATING PRESSURE	0 ~ 1.0MPa
AMBIENT TEMPERATURE	5 ~ 60°C
LUBRICANTS	ISO VG32 turbine oil, or equivalent oil is recommended.
HANDLE ROTATION ANGLE	At actuated position, rotation angle to clock- with or anticlockwise direction is 45°

MODEL NOs. & OTHER SPECIFICATIONS

Pipe Size	MODEL NUMBER			Effective Area [mm ²] < Cv value >	Mass [kg]
	3 Position Closed Center	3 Position Exhaust Center	3 Position Pressure Center		
Rc ¹ / ₄	DV-4102	DV-4102E	DV-4102P	10 <0.54>	1.1
Rc ³ / ₈	DV-4103	DV-4103E	DV-4103P	62 <3.3 >	
Rc ¹ / ₂	DV-4104	DV-4104E	DV-4104P	75 <4.1 >	2.3
Rc ³ / ₄	DV-4106	DV-4106E	DV-4106P	100 <5.4 >	
Rc1	DV-4110	DV-4110E	DV-4110P	105 <5.7 >	4.5

HOW TO ORDER

DV - 41

① ② ③ ④ ⑤

PRODUCT TYPE: DV-4100 SERIES

① Pipe Size

02 Rc¹/₄
 03 Rc³/₈
 04 Rc¹/₂
 06 Rc³/₄
 10 Rc1

② Function

NIL Closed Center
 E Exhaust Center
 P Pressure Center

③ Handle Lock

NIL Non-lock type (Std.)
 L Lock type

④ Positions

NIL 3 position
 D 2 position

⑤ Type of mounting

NIL Standard
 M Panel mount type
 (DV-4102 ~ 4104 model only)

DV-4102 * (Rc1/4)

Closed Center DV-4102	
Exhaust Center DV-4102E	
Pressure Center DV-4102P	
2-Position DV-4102D	

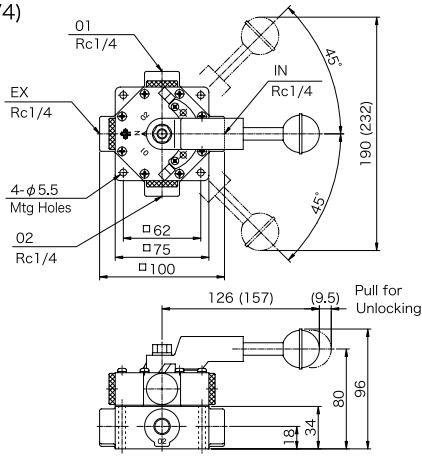

Dimensions in () are used for Handle-Lock types. Other dimensions are common.

315-010

DV-4102 *M (Rc1/4)

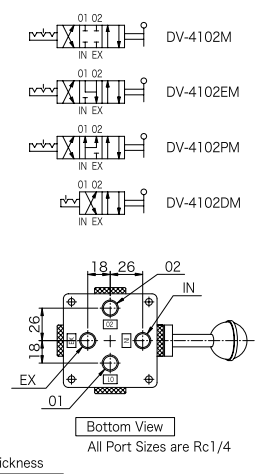
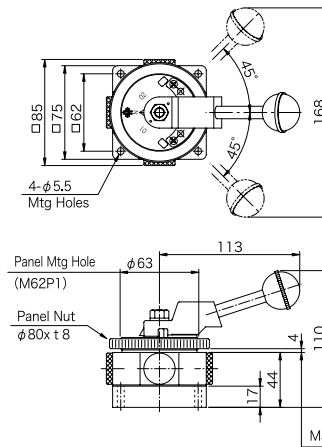

315-013

DV-4103 * (Rc3/8)

DV-4104 * (Rc1/2)

Closed Center DV-4103/04	
Exhaust Center DV-4103E/04E	
Pressure Center DV-4103P/04P	
2-Position DV-4103D/04D	

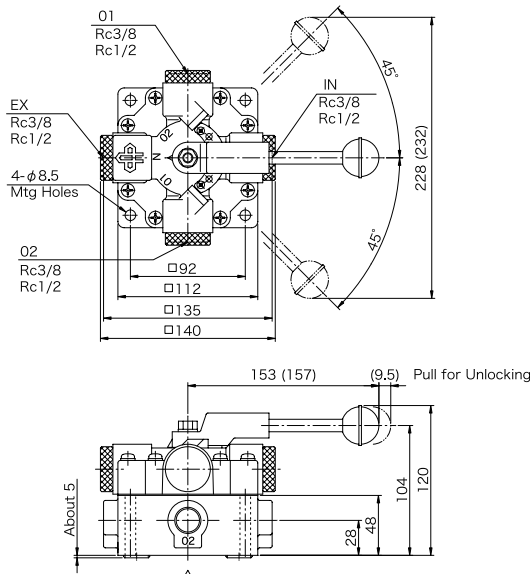

Dimensions in () are used for Handle-Lock types. Other dimensions are common.

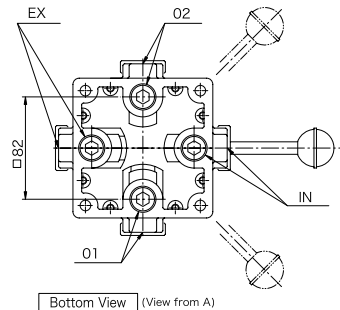

Bottom View (View from A)

Each port of bottom side is plugged with a pipe plug at factory shipment.

315-011

DV-4106 * (Rc3/4)

DV-4110 * (Rc1)

Closed Center DV-4106/10	
Exhaust Center DV-4106E/10E	
Pressure Center DV-4106P/10P	
2-Position DV-4106D/10D	

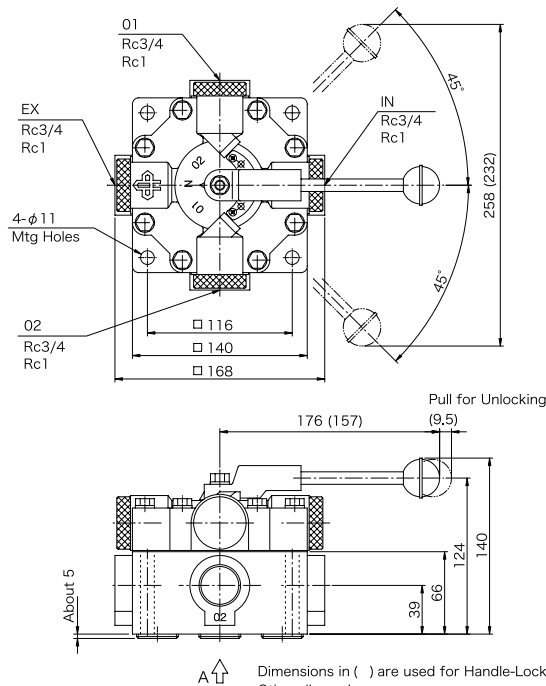

Dimensions in () are used for Handle-Lock types. Other dimensions are common.

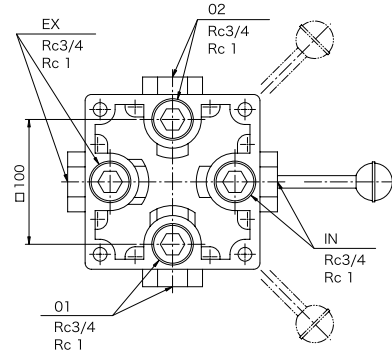

Bottom View (View from A)

Each port of bottom side is plugged with a pipe plug at factory shipment.

315-012

(By Dwg 315-010, -013, -011, -012)

SPEED CONTROLLER

SC-800Y/SC-100/SC-200 SERIES (Rc¹/₈~Rc¹/₂)



SC-800Y



SC-100

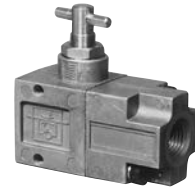

SC-200

MODEL NUMBERS & SPECIFICATIONS

MODEL NUMBERS		SC-801Y	SC-802Y	SC-102 SC-202	SC-103J SC-203J	SC-103 SC-203	SC-104 SC-204
PIPE SIZES		Rc ¹ / ₈	Rc ¹ / ₄		Rc ³ / ₈		Rc ¹ / ₂
FLUID		Filtered Compressed Air, Non-corrosive Gases					
OPERATING PRESSURE		1.0MPa					
CRACKING PRESSURE		0.05MPa		0.01MPa			
AMBIENT TEMPERATURE		5 ~ 60°C					
FREE FLOW	Flow at 0.5MPa (ℓ/min)	468	1940		4880	5890	
	Effective Area (mm ²)	7	29		73	88	
CONTROLLED FLOW(MAX.)	Flow at 0.5MPa (ℓ/min)	130	1000		2070		
	Effective Area (mm ²)	2	15		31		
MASS [kg]		0.06		0.14		0.22	

DIMENSIONS -mm-

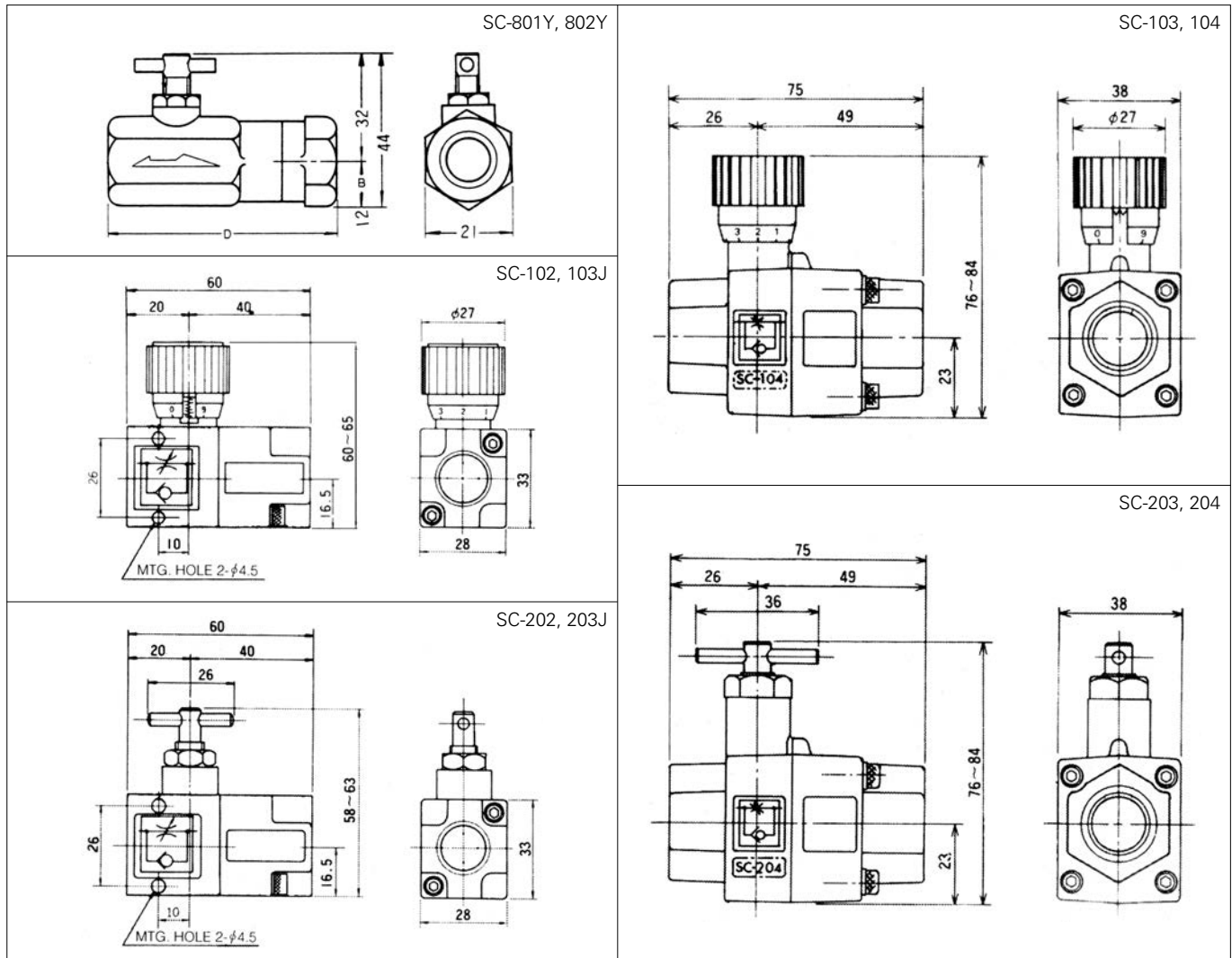

SPEED CONTROLLER

SC-300/SC-700 SERIES (Rc¹/₄~Rc¹/₂)



SC-300



SC-700

SPECIFICATIONS & MODEL NOS.

MODEL NUMBERS		SC-302	SC-303	SC-304	SC-706	SC-710	SC-712	SC-714
PIPE SIZES		Rc ¹ / ₄	Rc ³ / ₈	Rc ¹ / ₂	Rc ³ / ₄	Rc1	Rc1 ¹ / ₄	Rc1 ¹ / ₂
FLUID		Filtered Compressed Air, Non-corrosive Gases						
OPERATING PRESSURE		1.0MPa						
CRACKING PRESSURE		0.02MPa			0.04MPa	0.02MPa		
AMBIENT TEMPERATURE		5 ~ 60°C						
FREE FLOW	Flow at 0.5MPa (ℓ/min)	1800	3880	6290	8700	13380	16730	26500
	Effective Area (mm ²)	27	58	94	130	200	250	395
CONTROLLED FLOW(MAX.)	Flow at 0.5MPa (ℓ/min)	937	2200		3550		4820	14050
	Effective Area (mm ²)	14	33		53		72	210
MASS [kg]		0.14	0.35		0.6	1.0	1.8	3.1

DIMENSIONS -mm-

SC-302

SC-303, 304

SC-706, 710

DIMENSIONS IN () ARE FOR SC-710

SC-712, 714

DIMENSIONS IN () ARE FOR SC-714

VALVE OPENING ADJUSTMENT

NEEDLE VALVE (RIGHT HANDED THREAD)
 VALVE OPENING ADJ. SCREW (LEFT-HANDED THREAD)
 CLOCKWISE: CLOSE VALVE SEAT
 CLOCKWISE: CLOSE NEEDLE VALVE

USAGE
 USE VALVE OPENING ADJUSTING SCREW WHEN IT IS REQUIRED TO INCREASE THE CONTROLLED FLOW AMOUNT. CONTROL FLOW BEFORE FINAL ADJUSTMENT IS ADJUSTED BY THIS SCREW WHICH OPENS CHECK VALVE, AND FINE ADJUSTMENT IS MADE BY NEEDLE VALVE.

QUICK EXHAUST VALVE

G01 & QEV-3300 (Y) SERIES (Rc^{1/8}~Rc1)



G01



OEV

INSTALLATION EXAMPLE
OF QUICK EXHAUST VALVE:

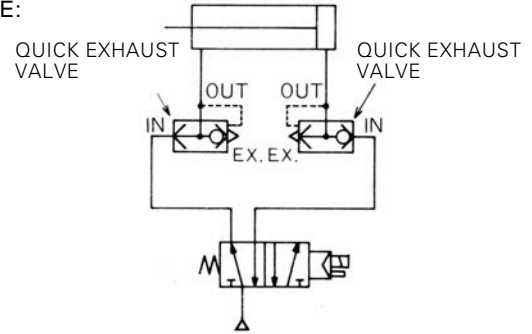

MODEL NUMBERS & SPECIFICATIONS

MODEL NUMBER		G01-100	G01-200	QEV-3303Y	QEV-3304Y	QEV-3306	QEV-3310
PIPE SIZE	IN, OUT	Rc ^{1/8}	Rc ^{1/4}	Rc ^{3/8}	Rc ^{1/2}	Rc ^{3/4}	Rc1
	EX	Rc ^{1/4}		Rc ^{1/2}		Rc1	
FLUID		Filtered Compressed Air					
MAX. OPERATING PRESSURE		1.0MPa					
CRACKING PRESSURE		0.03MPa					
AMBIENT TEMPERATURE		5 ~ 60°C					
EFFECTIVE AREA (mm ²) < Cv value >	IN-OUT	37 <2.0>		69 <3.7>		275 <14.9>	
	OUT-EX	33 <1.8>		82 <4.4>		330 <17.8>	
MASS [kg]		0.1		0.35		1.0	

DIMENSIONS -mm-

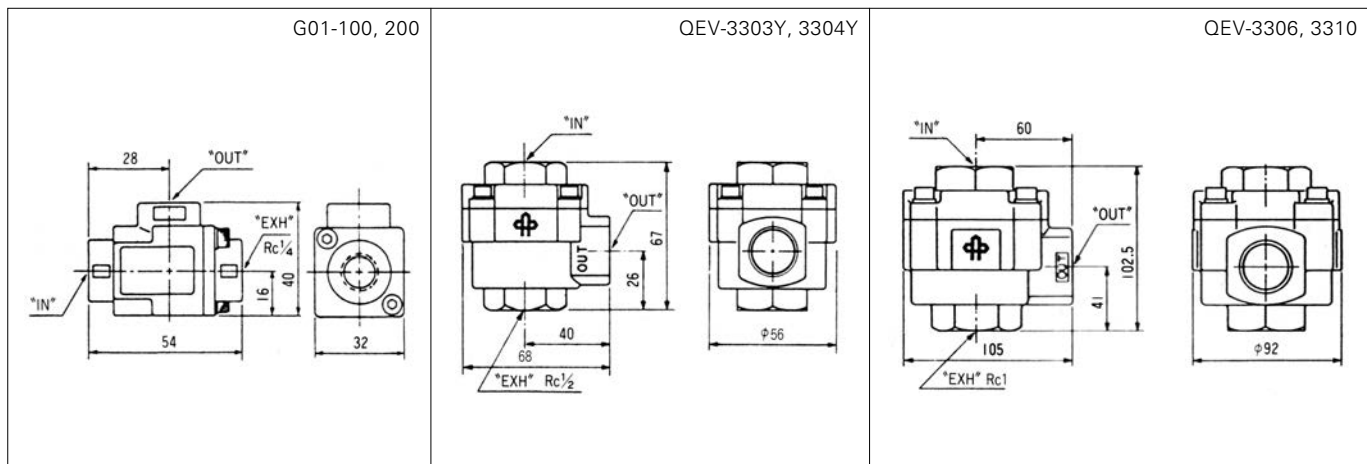

CHECK VALVE

CV-100/CV-200 SERIES (Rc¹/₄~Rc1¹/₂)



CV-100



CV-200



CV-200

MODEL NUMBERS & SPECIFICATIONS

MODEL NUMBERS	CV-102	CV-103J	CV-103	CV-104	CV-201	CV-202J	CV-202	CV-203	CV-204	CV-206	CV-210	CV-212	CV-214
PIPE SIZES	Rc ¹ / ₄	Rc ³ / ₈ (OVER PORT)	Rc ³ / ₈	Rc ¹ / ₂	Rc ¹ / ₈	Rc ¹ / ₄	Rc ¹ / ₄	Rc ³ / ₈	Rc ¹ / ₂	Rc ³ / ₄	Rc1	Rc1 ¹ / ₄	Rc1 ¹ / ₂
FLUID	Filtered Compressed Air, Non-corrosive Gases, Low viscosity non-corrosive Liquids.												
MAX. OPERATING PRESSURE	1.0MPa												
CRACKING PRESSURE	0.01MPa			0.015MPa			0.03MPa						
AMBIENT TEMPERATURE	5 ~ 60°C												
EFFECTIVE AREA (mm ²) <Cv value>	45 <2.4>	94 <5.1>	110 <5.9>	10 <0.5>	34 <1.8>	99 <5.4>	105 <5.7>	210 <11.4>	285 <15.4>	550 <29.7>	785 <42.4>		
MASS [kg]	0.12	0.17	0.17	0.04	0.35	0.6	0.6	0.88	0.88	4.0	4.0		

DIMENSIONS

—mm—

CV-201,202J

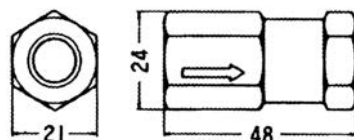

CV-102,103J

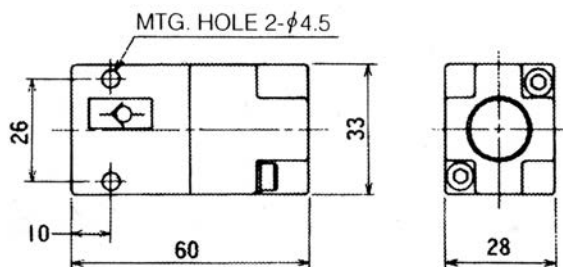

CV-103,104

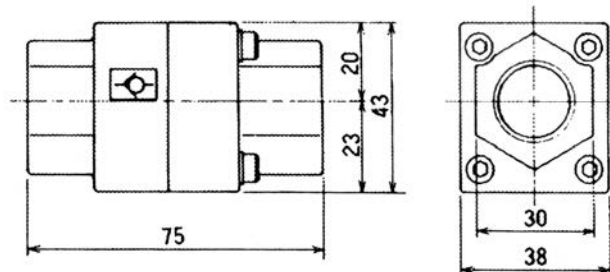

CV-206,210

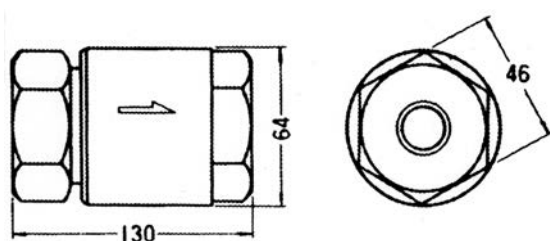

CV-212,214

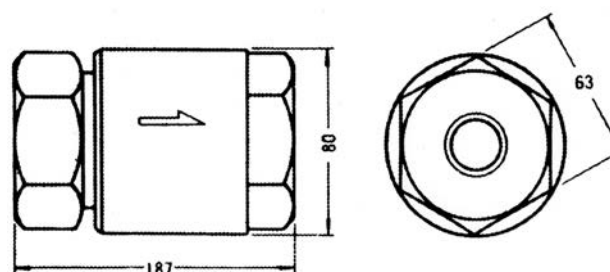

SHUTTLE VALVE

J01 & CV-3100 (Y) SERIES (Rc¹/₈~Rc1)



INSTALLATION EXAMPLE
OF SHUTTLE VALVE

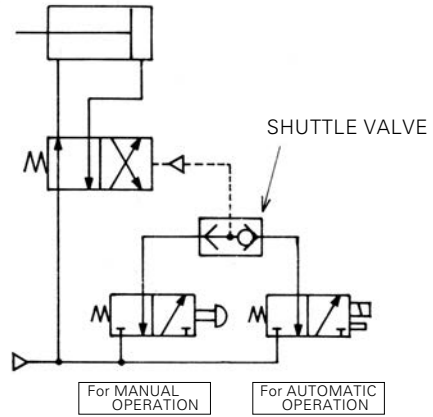

MODEL NUMBERS & SPECIFICATIONS

MODEL NUMBER	J01-100	J01-200	CV-3103Y	CV-3104Y	CV-3106	CV-3110	
PIPE SIZE (Port A, B & O)	Rc ¹ / ₈	Rc ¹ / ₄	Rc ³ / ₈	Rc ¹ / ₂	Rc ³ / ₄	Rc1	
FLUID	Filtered Compressed Air						
MAX. OPERATING PRESSURE	1.0MPa						
CRACKING PRESSURE	0.05MPa						
AMBIENT TEMPERATURE	5 ~ 60°C						
EFFECTIVE AREA (mm ²) < Cv value >	A - 0	25 <1.4>	28 <1.5>	90 <4.9>	110 <5.9>	250 <13.5>	275 <14.9>
	B - 0	23 <1.2>	28 <1.5>	95 <5.1>	115 <6.2>	305 <16.5>	320 <17.3>
MASS [kg]	0.13		0.37		1.2	1.1	

DIMENSIONS -mm-

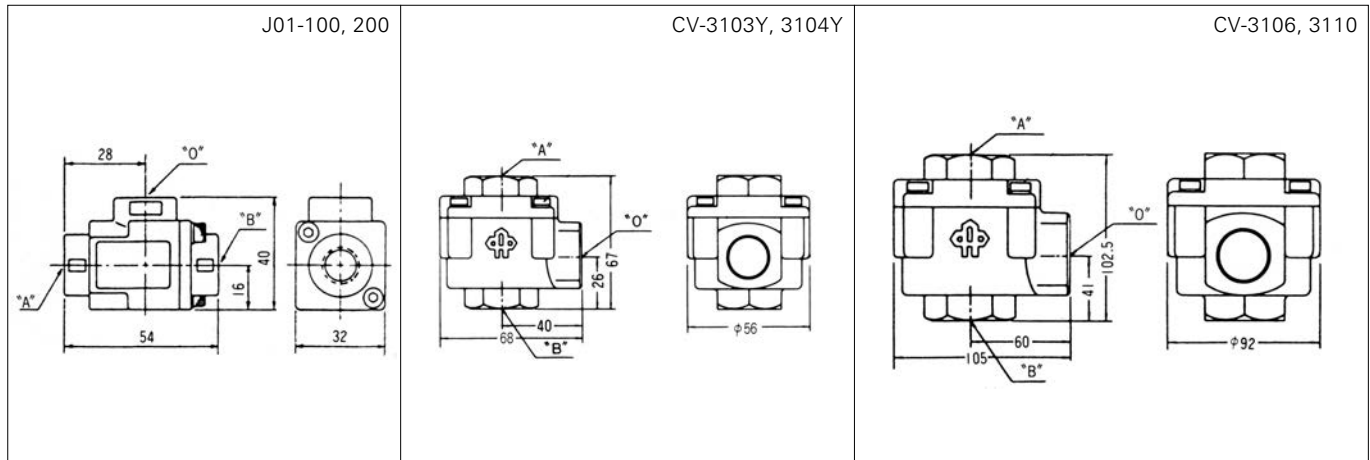

RELIEF VALVE

V31 SERIES (Rc¹/₈, Rc¹/₄)

COMPACT TYPE

Diaphragm type



SPECIFICATIONS

FLUID	Filtered Compressed Air, Non-corrosive Gases.
MAX. ALLOWABLE PRESSURE	0.85MPa
AMBIENT TEMPERATURE	5 ~ 60°C
OPERATION	Directly spring operated
TO LOCK ADJUSTING NEEDLE	Snap lock type (by one operation)

BASIC MODEL NOS. & OTHER SPECIFICATIONS

Pipe Size	MODEL NUMBER	Setting Pressure Range (MPa)	Gauge Port	Mass [kg]
Rc ¹ / ₈	V31-100-0000	0.02 ~ 0.7	Rc ¹ / ₈	0.18
	V31-100-C000	0.01 ~ 0.35		
	V31-100-B000	0.007 ~ 0.07		
Rc ¹ / ₄	V31-200-0000	0.02 ~ 0.7		
	V31-200-C000	0.01 ~ 0.35		
	V31-200-B000	0.007 ~ 0.07		

HOW TO ORDER

V31 - 00

① ② ③ ④

COMPACT RELIEF VALVE
V31 SERIES

① Pipe Size

- 1 Rc¹/₈
- 2 Rc¹/₄

② Adjusting Pressure Range

- 00 0.02 ~ 0.7MPa
- B0 0.007 ~ 0.07MPa
- C0 0.01 ~ 0.35MPa

③ Accessory

- 0 Without Accessory (Std.)
- B Bracket (with Plastic panel ring)
- R Panel ring (Aluminium)
- 2 Panel ring (Plastic)

④ Gauge

- 0 Without Gauge (Std.)
- T With Rc¹/₈ center back connection Gauge

ATTACHED GAUGES (OPTION)

For Product of	Model No. of Gauge	Full Range
V31-*00-0001	GAB401100	1MPa
V31-*00-C001	GAB401040	0.4MPa
V31-*00-B001	GAB401010	0.1MPa

DIMENSIONS -mm-

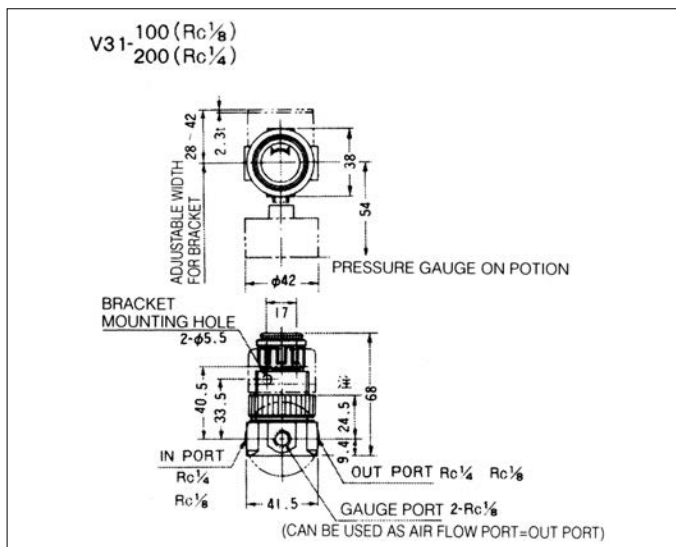

CHARACTERISTIC CURVE

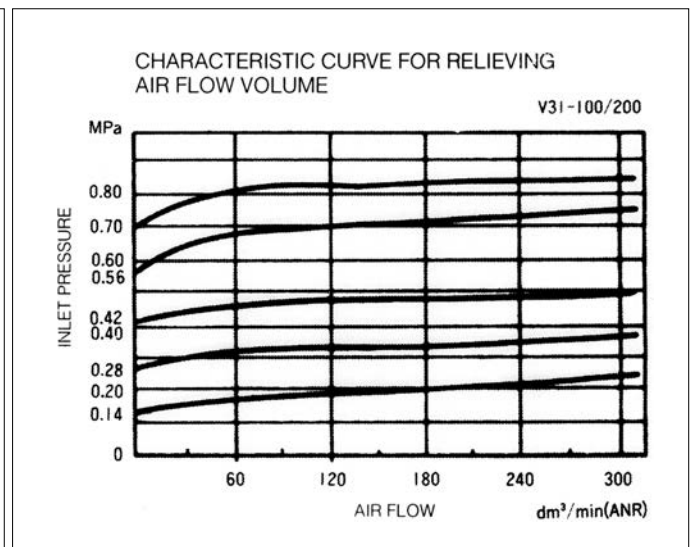

RELIEF VALVE

NSV-200 SERIES (Rc¹/₄~Rc1)

Diaphragm type



GAUGE ON OPTION

SPECIFICATIONS

FLUID	Filtered Compressed Air, Non-corrosive Gases.
MAX. ALLOWABLE PRESSURE	1.0MPa
AMBIENT TEMPERATURE	5 ~ 60°C
OPERATION	Directly spring operated

MODEL NOS. & OTHER SPECIFICATIONS

Pipe Size	MODEL NUMBER	Adjusting Pressure Range (MPa)	Gauge Port	Mass [kg]
Rc ¹ / ₄	NSV-202	0.02 ~ 0.8	Rc ¹ / ₈ 2 places	1.2
	NSV-202K3	0.02 ~ 0.3		
	NSV-202K1	0.02 ~ 0.1		
Rc ³ / ₈	NSV-203	0.02 ~ 0.8		1.3
	NSV-203K3	0.02 ~ 0.3		
	NSV-203K1	0.02 ~ 0.1		
Rc ¹ / ₂	NSV-204	0.02 ~ 0.8		2.8
	NSV-204K3	0.02 ~ 0.3		
	NSV-204K1	0.02 ~ 0.1		
Rc ³ / ₄	NSV-206	0.02 ~ 0.8		2.7
	NSV-206K3	0.02 ~ 0.3		
	NSV-206K1	0.02 ~ 0.1		
Rc1	NSV-210	0.02 ~ 0.8		
	NSV-210K3	0.02 ~ 0.3		
	NSV-210K1	0.02 ~ 0.1		

FLOW CHARACTERISTIC CURVE

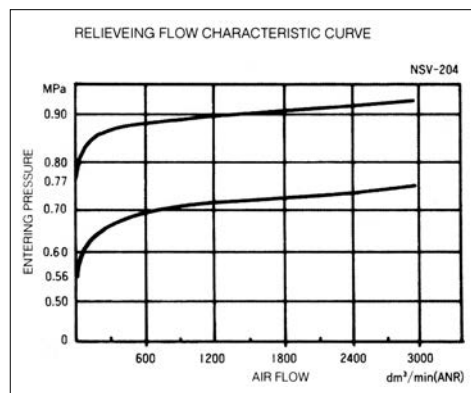

HOW TO ORDER

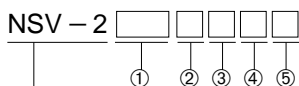

RELIEF VALVE NSV-200 SERIES

① Pipe Size

02	Rc ¹ / ₄
03	Rc ³ / ₈
04	Rc ¹ / ₂
06	Rc ³ / ₄
10	Rc1

② Panel mount & adjustment

NIL	T handle (Std.)
P	Panel mount with handwheel

③ Adjusting Pressure Range

NIL	0.02 ~ 0.8MPa
K3	0.02 ~ 0.3MPa
K1	0.02 ~ 0.1MPa

④ Gauge

NIL	Without Gauge (Std.)
T	With Rc ¹ / ₈ center back connection gauge

⑤ Bracket

NIL	Without Bracket (Std.)
B	With Bracket

DIMENSIONS -mm-

NSV-202~204

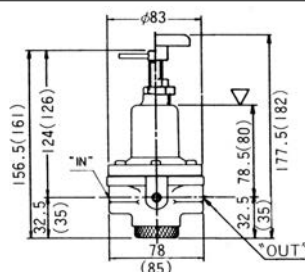

▽ PANEL MTG. HOLE I.D. 27
MAX. PANEL THICKNESS : 8mm
NOTE : DIMENSION IN () IS FOR NSV-204. OTHER DIMENSIONS ARE COMMON.

NSV-206, 210

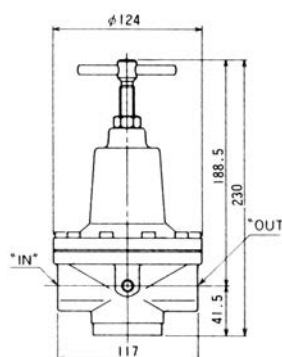

REMO-CON RELIEF VALVE

NSV-500 SERIES (Rc^{1/2}~Rc1)



GAUGE ON OPTION

SPECIFICATIONS

FLUID	Compressed Air, Non-corrosive Gases.
MAX. ALLOWABLE PRESSURE	1.0MPa
AMBIENT TEMPERATURE	5 ~ 60°C
OPERATION	External pilot operated Diaphragm type

MODEL NOS. & OTHER SPECIFICATIONS

Pipe Size	MODEL NUMBER	Mass [kg]
Rc ^{1/2}	NSV-504	0.8
Rc ^{3/4}	NSV-506	2
Rc1	NSV-510	

HOW TO ORDER

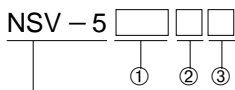

RELIEF VALVE NSV-500 SERIES

① Pipe Size

04	Rc ^{1/2}
06	Rc ^{3/4}
10	Rc1

② Gauge

NIL	Without Gauge (Std.)
T	With T type Gauge; GAB501100

③ Bracket

NIL	Without Bracket (Std.)
B	With Bracket

MODEL NOS. OF PILOT REGULATOR

MODEL NUMBERS	Adjusting Pressure Range (MPa)	Purpose
NRV-802	0.02 ~ 0.70	Precision
NRV-802K4	0.01 ~ 0.40	
NRV-802K2	0.01 ~ 0.20	
NRV-302	0.02 ~ 0.80	General
NRV-302K3	0.01 ~ 0.30	
NRV-302K1	0.01 ~ 0.10	
R31-200-0000	0.02 ~ 0.70	
R31-200-C000	0.01 ~ 0.35	

CHARACTERISTIC CURVE

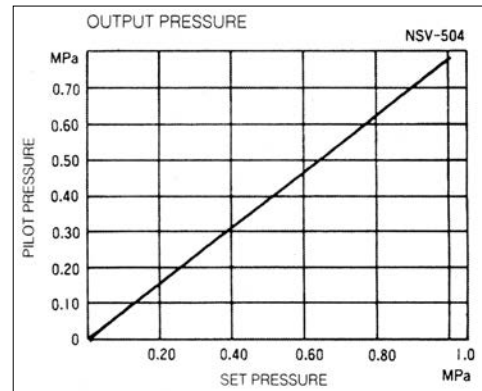

DIMENSIONS

—mm—

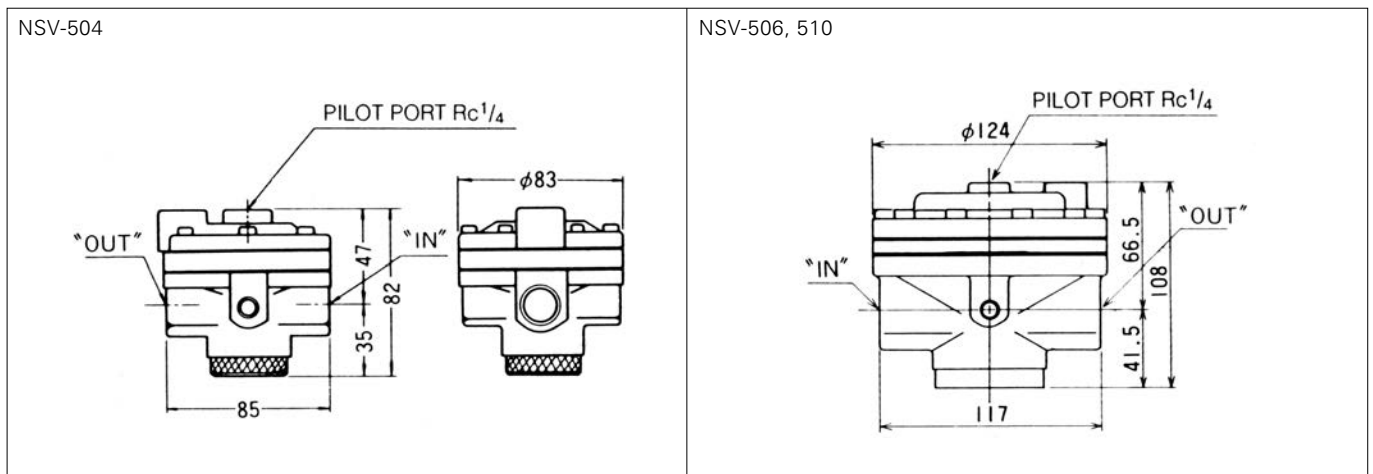

RELIEF VALVE

NSV-300 SERIES (Rc^{1/8}~Rc^{1/2})



SPECIFICATIONS

FLUID	Filtered Compressed Air
MAX. ALLOWABLE PRESSURE	1.0MPa
AMBIENT TEMPERATURE	5 ~ 60°C
OPERATION	Directly spring operated
MASS (kg)	0.15 (NSV-301), 0.16 (NSV-302, -303) 0.18 (NSV-304)

HOW TO ORDER

NSV - 3

① ②

① Pipe size

01	R ^{1/8}
02	R ^{1/4}
03	R ^{3/8}
04	R ^{1/2}

POP RELIEF VALVE
NSV-300 SERIES

② Set Pressure Range

Marks for adjusting Spring	Adjustable Pressure Range Pre-set (kgf/cm ²)	Standard Factory Setting on Models without optional pre-setting		
		Pre-set Pressure* (kgf/cm ²)	Blowoff Pressure (kgf/cm ²)	Shutdown Pressure (kgf/cm ²)
Nil (Standard)	3.1 ~ 7	7.0	7.0 ± 0.2	4.9 and above
K14 (Option)	7.1 ~ 1.4	10	9.9 ± 1	6.9 and above
K3 (Option)	1.6 ~ 3.0	3.0	3.0 ± 0.2	2.1 and above
K1.5 (Option)	1.1 ~ 1.5	1.5	1.5 ± 0.2	1.05 and above

*Relieving pressure is pre-set by standard pre-set pressure listed above at factory on delivery.

*other pre-set pressure are available on option.

In this case, specify "S" or "F" and "Pre-set pressure desired by kgf/cm² unit in this case".

S: Adjusting screw is fixed firmly and readjusting is impossible.

F: Adjusting screw is fixed by lock nut and readjusting is possible.

But it is not necessary to specify adjusting spring.

[EX] NSV-304F2.5

NSV-304K3 is pre-set at pressure of 2.5kgf/cm².

And the adjusting screw is fixed by adhesive.

DIMENSIONAL DRAWING —mm—

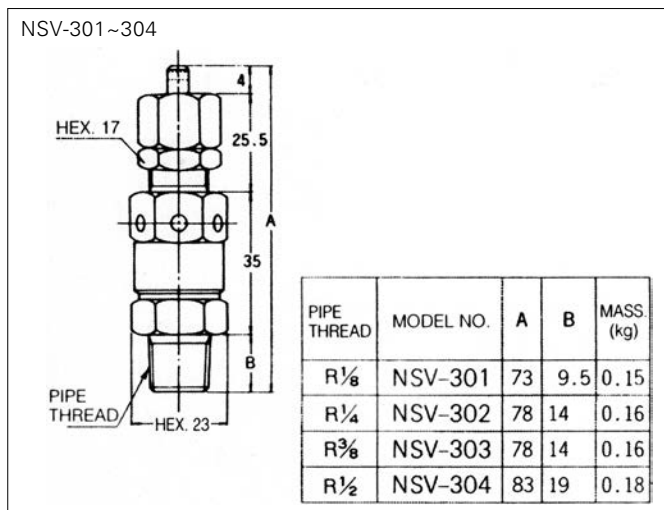

FLOW CHARACTERISTICS CURVE

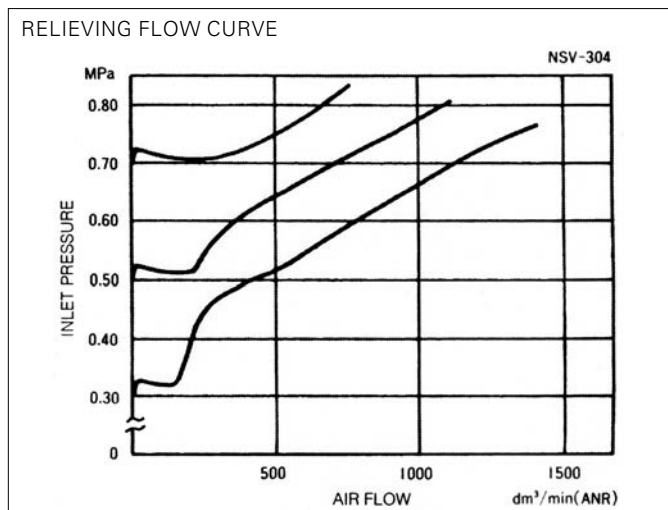

CUSHION VALVE

CUV-400 SERIES (Rc^{1/2})

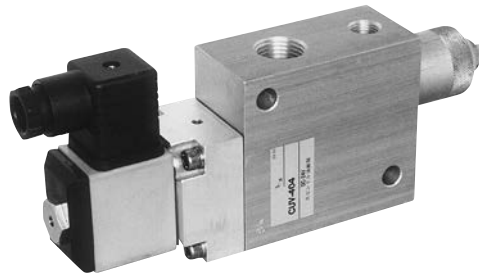

CUV-400

SPECIFICATIONS

MODEL NUMBER	CUV-404	
OPERATION	Electrical	
PIPE SIZE	"V" "C" Port	Rc ^{1/2}
	"P" Port	Rc ^{1/4}
FLUID	Compressed Air	
MAX. ALLOWABLE PRESSURE	1.0MPa	
OPERATING PRESSURE RANGE	0.25 ~ 0.6MPa	
AMBIENT TEMPERATURE	5 ~ 50°C	
RATED VOLTAGE (-15 ~ +10%)	<ul style="list-style-type: none"> •AC100V 50/60Hz, 110V 60Hz •AC200V 50/60Hz, 200V 60Hz •DC24V 	
LUBRICANT	Turbine Oil ISO VG 32 or equivalent Recommended	
EFFECTIVE AREA	100mm ²	
APPROPRIATE CYLINDER BORE SIZE*	max. φ80 (φ100)	
LOAD EFFICIENCY OF CYLINDER**	To be less than 40%	
MASS	1.0kg	

*The cylinder bore in () is available under limited conditions.
 **Included mass of the cylinder's piston and rod.

HOW TO ORDER

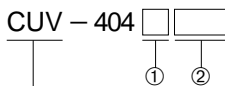

CUSHION VALVE:CUV-400 SERIES

① Pilot Air Supply

NIL Internal pilot supply (Std.)
 P External pilot supply

② Rated Voltage

AC100V AC100V 50/60Hz, 110V 60Hz
 AC200V AC200V 50/60Hz, 220V 60Hz
 DC 24V DC24V

DIMENSIONS

-mm-

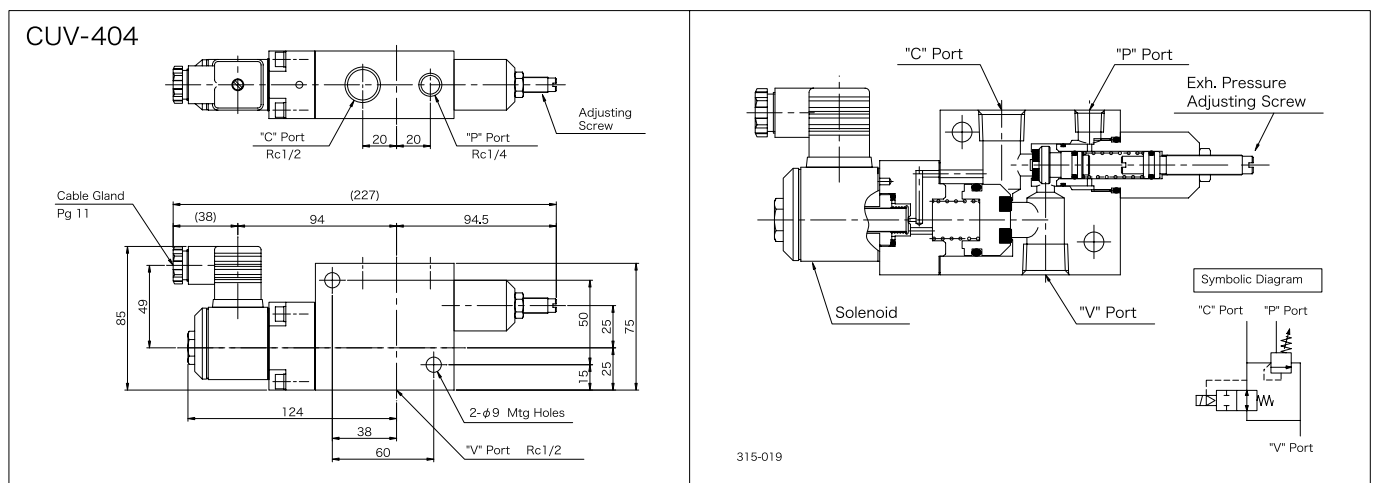

315-019

EJECTOR UNIT FOR VACUUM GENERATION

VC1-101 SERIES (Rc¹/₈)

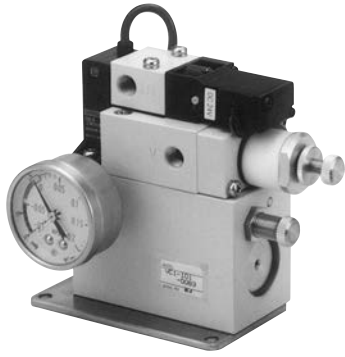

VC1-101-0000



VC1-101-4000

SPECIFICATIONS

FLUID	Compressed air filtered with 25µm rated or finer rated filter			
OPERATING PRESSURE RANGE	0.35 ~ 0.5MPa			
PIPE SIZE	Rc ¹ / ₈ : In & Vacuum Port			
AMBIENT TEMPERATURE	5 ~ 50°C			
GENERATED VACUUM DEGREE	-0.08MPa or more	Operating pressure at 0.4MPa		
SUCTION AIR AMOUNT	18 ±1.5dm ³ /min. (ANR)			
AIR CONSUMPTION	30 ~ 40dm ³ /min. (ANR)			
RATED VOLTAGE OF SOLENOID VALVE	<ul style="list-style-type: none"> • AC 100V 50/60Hz, 110V 60Hz • AC 200V 50/60Hz, 220V 60Hz • DC 24V 			
ALLOWABLE VOLTAGE FLUCTUATION	-15 ~ +10%			
TYPE OF SOLENOID VALVE	2-port, Normally open			
ELECTRIC CURRENT OF SOLENOID	50Hz	60Hz		
HOLDING (Inrush) ELECTRIC CURRENT	AC 100V	0.015 (0.018) A	0.014 (0.016) A	
	AC 200V	0.011 (0.013) A	0.009 (0.011) A	
	DC 24V	0.070A		

SPECIFICATIONS OF VACUUM SENSOR

SUPPLY VOLTAGE	12 ~ 24V DC (20mA max.)
SETTING OF VACUUM DEGREE	-400 ±40mmHg (set at factory)
OUTPUT & CAPACITY	NPN open collector, 80mA max. (30V)
OPERATION LAMP	Red LED (turned on at and over set vacuum degree)

(lighted on more than vacuum setting)

MODEL NOs. & OTHERS

Pipe Size	MODEL NUMBER	Mass [kg]	Rated Voltage & Type of Solenoid Valve	
Rc ¹ / ₈	VC1-101-0061	1.0	AC 100V	2-Port Normal open
	VC1-101-0062		AC 200V	
	VC1-101-0063		DC 24V	
	VC1-101-4061	0.5	AC 100V	
	VC1-101-4062		AC 200V	
	VC1-101-4063		DC 24V	

HOW TO ORDER

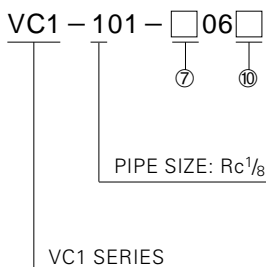

⑦ Unit Composition

0	Built-in auto-vacuum-destruction valve, silencer, flow control screw and vacuum gauge
4	Basic type with 2-port sol. Valve, suction filter and vacuum sensor

⑩ Rated Voltage

1	AC 100V 50/60Hz, 110V 60Hz
2	AC 200V 50/60Hz, 220V 60Hz
3	DC 24V

DIMENSIONS -mm-

VC1-101-0061
VC1-101-0062
VC1-101-0063

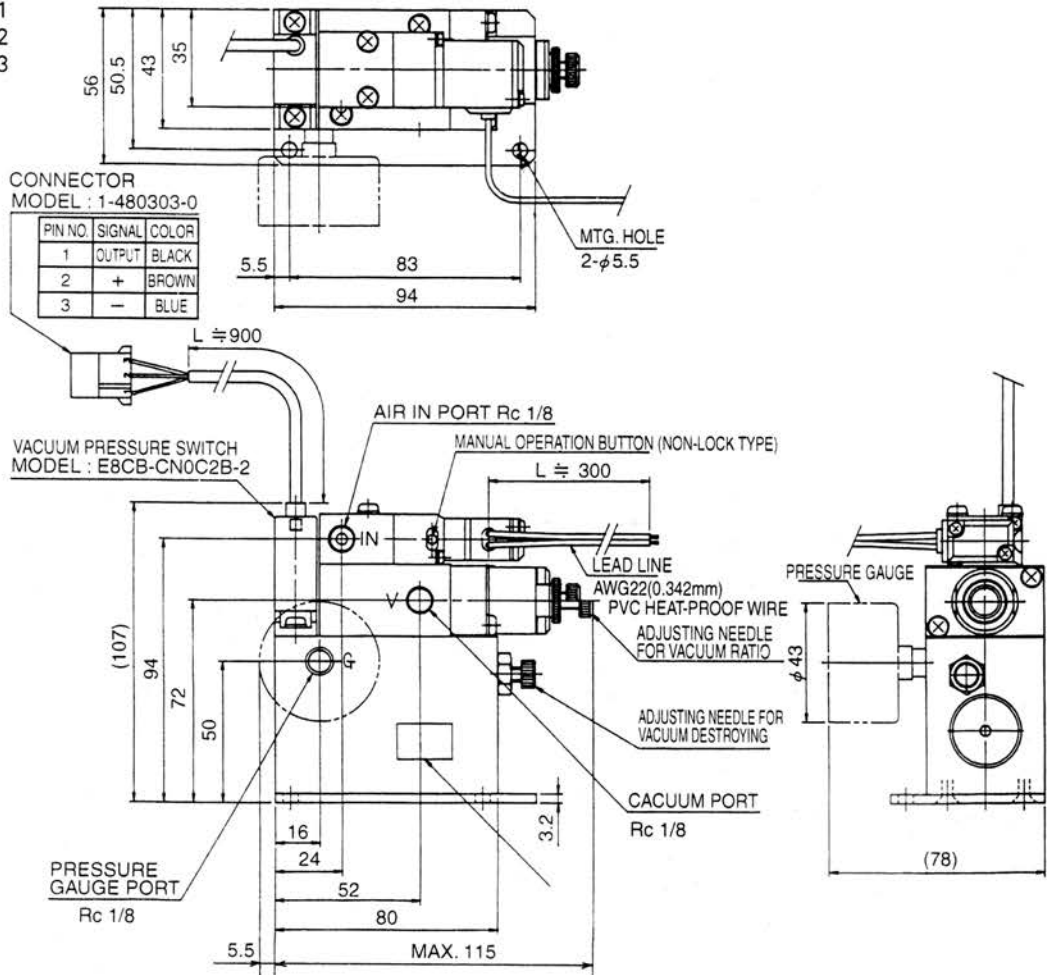

VC1-101-4061
VC1-101-4062
VC1-101-4063

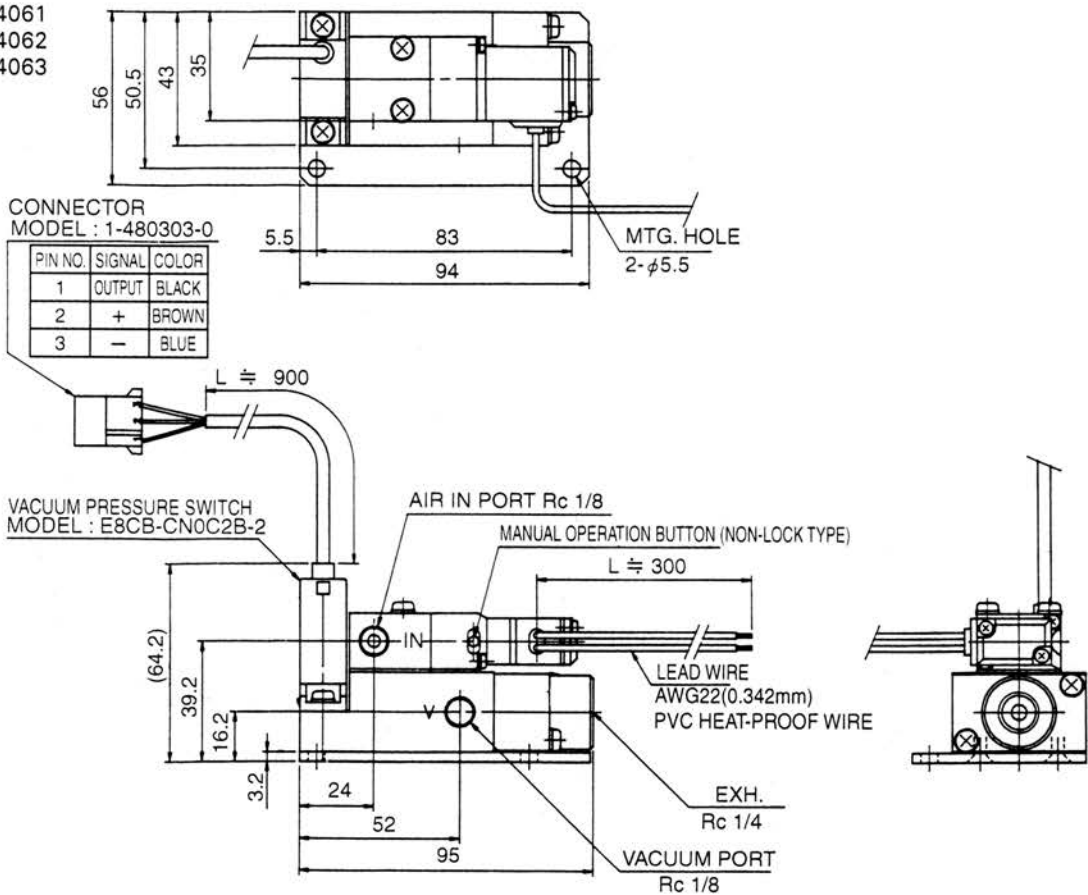

PRESSURE SWITCH

PSD-101 SERIES

SPECIFICATIONS



FLUID	Filtered Compressed Air, Non-corrosive Gases	
MAX. ALLOWABLE PRESSURE	1.0MPa	
AMBIENT TEMPERATURE	-10°C ~ 50°C	
CONTACT POINT	1c	
CONTACT POINT CAPACITY (Resistance Load)	High sensitive type	<ul style="list-style-type: none"> •15A/AC 125V. 250V •2A/DC 24V
	Small electric current type (For programable controller)	<ul style="list-style-type: none"> •1 ~ 100mA/AC 100V •3 ~ 100mA/DC 24V
REPEATABILITY	Standard type	0.003MPa
	For K5, K1	0.002MPa
PIPE SIZE	Pressure air sensing port Rc ¹ / ₄ Gauge port: Rc ¹ / ₈	
MASS (kg)	1.5	

MODEL NOs. & OTHER SPECIFICATIONS

MODEL NUMBER		Set Pressure Range MPa	Hysteresis MPa	Error of * Setting dial
High sensitive type	Small electric current type (for programable controller)			
PSD-101	PSD-101A	0.3 ~ 0.9	max. 0.01	±3% FS
PSD-101K5	PSD-101AK5	0.05 ~ 0.5	max. 0.01	
PSD-101K1	PSD-101AK1	0.01 ~ 0.1	max. 0.005	

*NPS-101 can be set the switching pressure by setting dial without pressure gauge. This value shows the difference between set value adjusted by the dial and pressure realized.

HOW TO ORDER

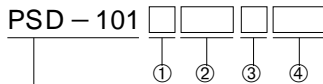

PRESSURE SWITCH PSD-101 SERIES

① Pressure

NIL	High sensitive type
A	Small electric current type (for programable controller)

② Set Pressure Range

NIL	0.3 ~ 0.9MPa (Std.)
K5	0.05 ~ 0.5MPa
K1	0.01 ~ 0.1MPa

④ Gauge

NIL	without Gauge (Std.)
T	with T type Gauge (ø50)

③ Pilot lamp for sensing

NIL	without pilot lamp (Std.)
S**	with pilot lamp

S** for models with pilot lamp

Colour	Voltage		
	AC 100V	AC 200V	DC 24V
Transparent	ST1	ST2	<ul style="list-style-type: none"> • ST3 • ST3P
Green	SG1	SG2	<ul style="list-style-type: none"> • SG3 • SG3P
Red	SR1	SR2	<ul style="list-style-type: none"> • SR3 • SR3P

* If "A" model selected, pilot lamp should be specified AC 100V or DC 24V.

* On "S * 1", "S * 2" and "S**P" model, pilot lamp is turned off at pressure increase.
On "S * 3" model, pilot lamp is turned on at pressure increase.

DIMENSIONS -mm-

PSD-101

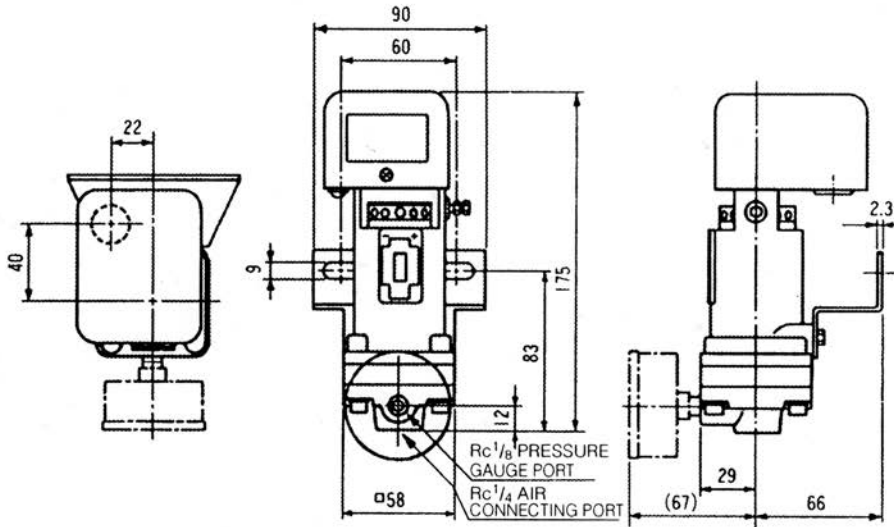

CIRCUIT DWG. A

○ FOR AC VOLT (AC-100V/200V)

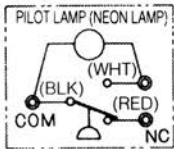

CIRCUIT DWG. B

○ FOR DC VOLT (DC-24V)

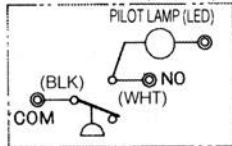

CIRCUIT DWG. C

○ FOR DC VOLT (DC-24V)

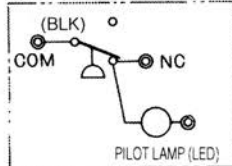

SAMPLES OF CIRCUIT

○ FOR AC VOLT

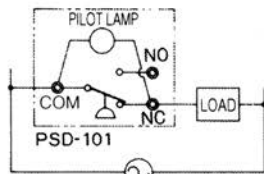

ELECT. POWER SOURCE
AT PRESSURE UP PILOT
LAMP ON LOAD OFF
(NEEDED CHANGE OF
CONNECTION FOR LAMP)

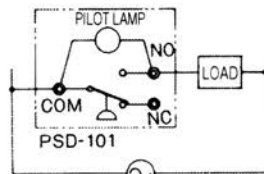

ELECT. POWER SOURCE
AT PRESSURE DOWN PILOT
LAMP ON LOAD OFF
(CIRCUIT DWG. A)

○ FOR DC VOLT

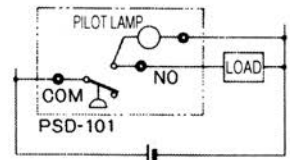

ELECT. POWER SOURCE
AT PRESSURE UP
PILOT LAMP ON LOAD ON
(CIRCUIT DWG. B)

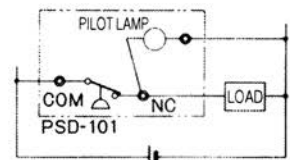

ELECT. POWER SOURCE
AT PRESSURE DOWN
PILOT LAMP ON LOAD ON
(CIRCUIT DWG. C)

PRESSURE SWITCH

P02-200 SERIES (R¹/₄)



SPECIFICATIONS

FLUID	Compressed Air and Non-corrosive gases
WITHSTAND PRESSURE	0.7MPa
PORT SIZE	R ¹ / ₄ (Male)
AMBIENT TEMPERATURE	5 ~ 50°C (Humidity: 95% max.)
SPECIFYING SET PRESSURE RANGE	0.03 ~ 0.37 MPa (OFF setting: setting pressure of switch off)
REPEATABILITY	Within 0.013MPa against the set pressure (@20°C)
CONTACT POINT TYPE	1c (0.1A/125V AC, 0.1A/30V DC)
MASS	30g

MODEL NO:

P02 - 200 -

0	*	*	7
---	---	---	---

7	8	9	10
---	---	---	----

MODEL NO.*2	Equipped Devices *3
P02-200-0**0	Without Lamp, Soldering Type Terminals, without Lead Wire
P02-200-0**7	With Lamp, connector connection, with Cable (3 lead, 350mm)

*2. Fill 8th and 9th digits for pre-set pressure with mark in the table of <Marks for Setting Pressure> under mentioned.

*3. When soldered wire (350mm) is required on basic model; P02-200-0**0, replace 0 with 2 at 10th digit of model no.

HOW TO ORDER

P02 - 200 -

0	*	*	2
---	---	---	---

7	8	9	10
---	---	---	----

⑦ Accessories

- 0 Nil
- 1 with Drip Proof Cover

⑧⑨ Setting Pressure

Mark of Setting Pressure
See Above Table

⑩ Wiring & Pilot Lamp

- 0 Soldering Type, no wiring, no lamp
- 2 350mm Wire soldered, no lamp
- 7 Connector Type with 350mm leads, With lamp

<Marks for Setting Pressure>

Marks for Setting Pressure	Pressure Setting (for OFF)	Pressure Differential for Switching. For reference.
00	≤0.005MPa	0.005MPa
03	0.03MPa	
05	0.05	
08	0.08	0.010
12	0.12	
16	0.16	
20	0.20	
25	0.25	0.020
32	0.32	

DIMENSIONS -mm-

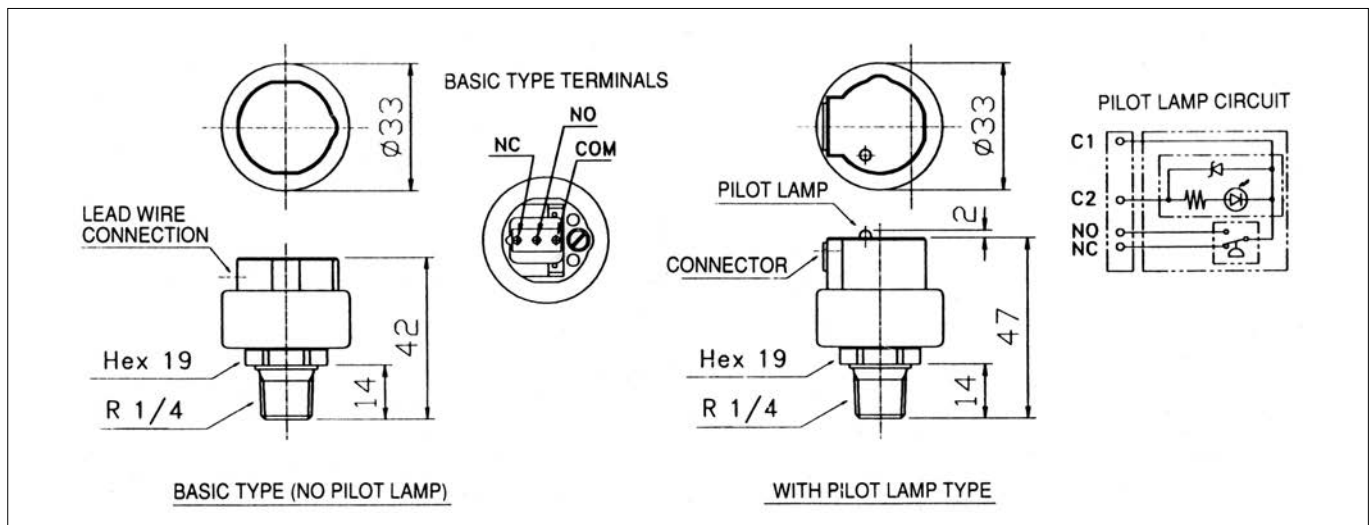

AIR LIMITER

S51 SERIES

SPECIFICATIONS



GAUGE ON OPTION



GAUGE ON OPTION

MODEL NO.	S51-1※1-※0※※(Std.)		S51-1※1-※3※※
FLUID	Filtered Clean Compressed Air, (by 5μm rated filter), No Oiliness		
PIPE SIZE	Rc ¹ / ₈ (Both IN port and OUT (Sensing) port)		
AMBIENT TEMPERATURE	5 ~ 50°C		
METERING ORIFICE	φ 0.7mm (Standard)		φ 1.2mm
SENSING GAP RANGE	0.01 ~ 0.15mm	0.16 ~ 0.3mm	0.01 ~ 0.15mm
	SUPPLY PRESSURE FOR IN PORT	0.2MPa	0.3MPa *2
	SENSING NOZZLE DIA.*1	φ 1mm	
	SENSING ACCURACY	±0.01mm	±0.02mm
AIR CONSUMPTION	10dm ³ /min (ANR)	13dm ³ /min (ANR)	30dm ³ /min (ANR)
CONTACT TYPE OF SWITCH	1c (Single Pole, Double Throw)		
PROTECTION SPECIFICATION	IP-67		
ELECTRICAL CONNECTION	G ¹ / ₂ Conduit port (Std.), or CAPCON or CORDLOCK added		
OUT PORT SENSING TUBING	φ 4mm I.D. tubing, max. 4m length		
AVAILABLE RANGE OF ELECTRIC CURRENT (TYPE OF SWITCH FOR OUTPUT)	<ul style="list-style-type: none"> ○ Small electric current type (for programable controllers); <ul style="list-style-type: none"> ● 1 ~ 100mA/AC100V or DC24V ○ High sensitive type; <ul style="list-style-type: none"> ● 30 ~ 100mA/AC100V ● 20 ~ 100mA/AC200V ● 35 ~ 100mA/DC24V 		
PILOT LAMP & DARKNESS LEAKAGE CURRENT	<ul style="list-style-type: none"> ○ Neon Lamp/0.6mA: for use on models rated AC100/200V ○ LED Lamp/0.85mA: for use on models rated DC24V 		
MASS	0.5kg		

* 1. Use one sensing nozzle for one S51 Air limiter unit.

* 2. Economiter is impossible to install in the system of 0.3MPa supply pressure.

MODEL Nos. OF SINGLE UNIT

Metering Orifice	Type of switch	Small electric current type switch		High Sensitive Type Switch		
	Rated Voltage & Pilot Lamp	AC100V NEON	DC24V *1 LED/RED	AC100V NEON	AC200V NEON	DC24V *1 LED/RED
φ 0.7mm	Basic Type	S51-101-0001	S51-101-0003 [S51-101-0004]	S51-101-000B	S51-101-000C	S51-101-000D [S51-101-000E]
	With Mobile Marker Gauge	S51-101-1001	S51-101-1003 [S51-101-1004]	S51-101-100B	S51-101-100C	S51-101-100D [S51-101-100E]
φ 1.2mm	Basic Type	S51-101-0301	S51-101-0303 [S51-101-0304]	S51-101-030B	S51-101-030C	S51-101-030D [S51-101-030E]
	With Mobile Marker Gauge	S51-101-1301	S51-101-1303 [S51-101-1304]	S51-101-130B	S51-101-130C	S51-101-130D [S51-101-130E]

◎ Manifold types are specified at 5th digit of model no. by inserting figure (2 ~ 5) that required for forming manifold : S51 - 1 □ 1 - ※※※※

* 1. Models for use of DC24V are available 2 kinds of switch wiring of ⊖COM wiring (Std.) and ⊕COM wiring. Model nos. of ⊕COM wiring are shown in brackets [] in above table.

HOW TO ORDER

S51 - 1 □ 1 - ※ ※ ※ ※

⑤ ⑦ ⑧ ⑨ ⑩

⑤ Single unit or Manifold

0	Single unit
2~5	Manifold type and number of single units

⑦ Pressure Gauge

0	without
1	with gauge of mobile marker type. Range: 0 ~ 0.4MPa

⑧ Dia. of Metering Orifice

0	φ 0.7mm (Std.)
3	φ 1.2mm

⑨ Types of Electrical Connection

0	G ¹ / ₂ conduit port
1	Capcon added
2	Cordlock added

⑩ Current Capacity of switch / Rated Voltage

Small electric current type	1 3 4	1 ~ 100mA/AC100V	
		⊖ COM wiring	⊕ COM wiring
High sensitive type	B	30 ~ 100mA/AC100V	
	C	20 ~ 100mA/AC200V	
	D	35 ~ 100mA/DC24V (⊖ COM wiring)	
	E	35 ~ 100mA/DC24V (⊕ COM wiring)	

DIMENSIONS -mm-

SINGLE UNIT

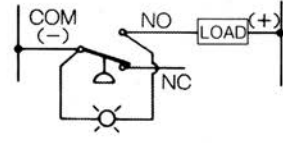
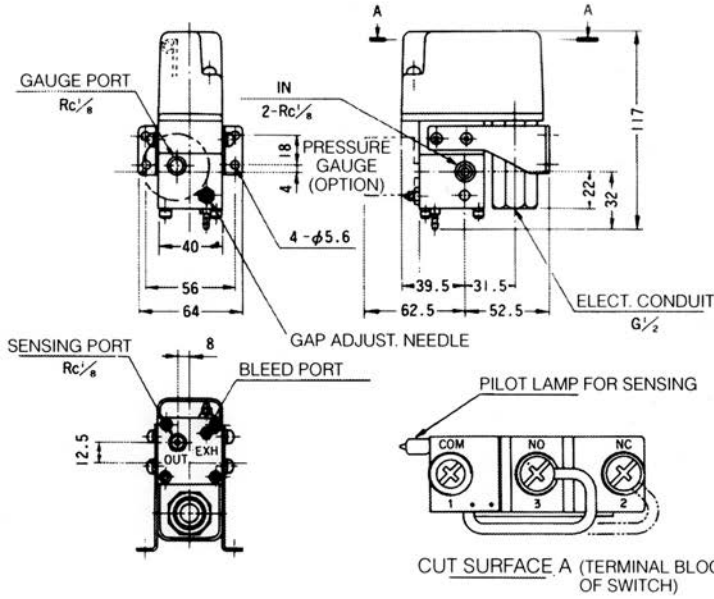

⊕ WIRING

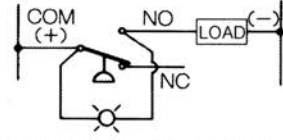

NOTE) FOR DC VOLTAGE, ACCORDING TO POLARITY OF LED PILOT LAMP, THERE ARE 2 KINDS OF WIRING METHOD LIKE ⊖COM AND ⊕COM WIRINGS.

● RESPONSE CHARACTERISTICS

SUPPLY PRESS. 0.2~0.3MPa
OUT SIDE TUBING : 4mm dia. TUBINGS.

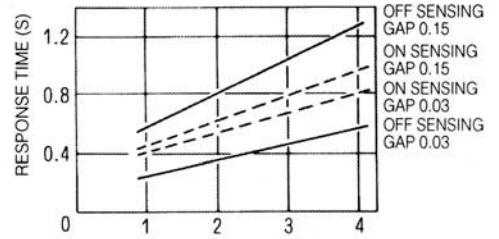

RESPONSE TIME : THE TIME FROM MOMENT OF ACCESSION TO THE NOZZLE OF THE WORK TILL OUTPUT OF AIR LIMITER.
ON SENSING : TO BE SENSED ON THE WAY THAT THE WORK IS APPROACHED.
OFF SENSING : TO BE SENSED ON THE WAY THAT THE WORK IS SEPARATED FROM NOZZLE.

MANIFOLD TYPE

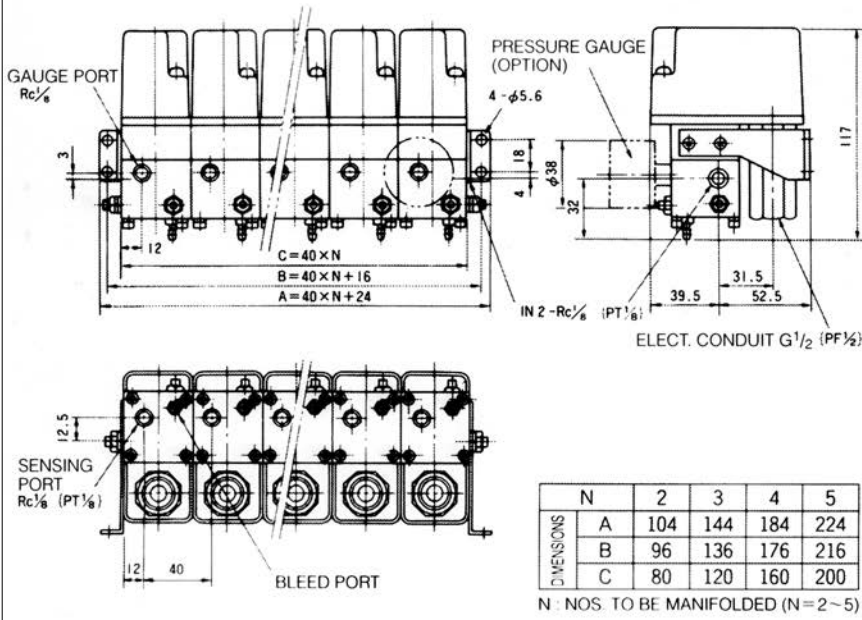

N	2	3	4	5
A	104	144	184	224
B	96	136	176	216
C	80	120	160	200

N : NOS. TO BE MANIFOLDED (N=2~5)

● DIFFERENTIALS

SENSING LINE TUBING
4mm I.D. x 4M

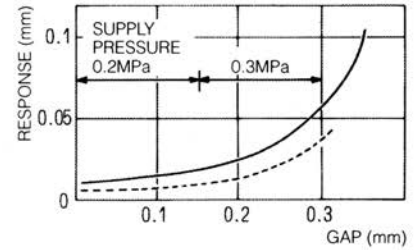

— SMALL CURRENT TYPE
- - - HIGH SENSIBLE TYPE

AIR LIMITERS Stacked with ECONOMITER

S51 SERIES



Compact Air Limiter manifold joined with Economiter
(Pressure gauges are optional)

CODE OF MODEL NO.

S51 - 1

※

 1 -

※

※

※

※

⑤ ⑦ ⑧ ⑨ ⑩

⑤ Number of Air limiter

0	Single unit
2	2 units
3	3 units (max.)

⑦ Pressure Gauge

2	without
3	with gauge of mobile marker (0 ~ 0.4MPa)

⑧ Metering Orifice

0	φ 0.7mm (Std.)
3	φ 1.2mm

⑨ Electrical Connection

0	G1/2 (Std. port)
1	with Capcon
2	with Cordlock

⑩ Rated Voltage

MARKS	ECONOMITER	AIR LIMITER / SWITCH	
1	AC 100V	AC 100V	S type
3	DC 24V	DC 24V	S type, - COM
4	DC 24V	DC 24V	S type, + COM
B	AC 100V	AC 100V	H type
C	AC 200V	AC 200V	H type
D	DC 24V	DC 24V	H type, - COM
E	DC 24V	DC 24V	H type, + COM
G	DC 24V	AC 100V	S type
N	DC 24V	AC 100V	H type
H	AC 100V	DC 24V	S type, - COM
K	AC 100V	DC 24V	S type, + COM
R	AC 100V	DC 24V	H type, - COM
U	AC 100V	DC 24V	H type, + COM

NOTE) S type: Small electric current type
H type: High sensitive type

SPECIFICATIONS

PIPE SIZE	Rc1/4 for IN port, Rc1/8 for sensing port		
FLUID	Compressed air filtered by 5μm filter element (No oiliness)		
OPERATING PRESSURE	0.2MPa Supply pressure		
AMBIENT TEMPERATURE	5 ~ 50°C		
ELECTRICAL CONNECTIONS	Economiter: MVS-214-02KS-07 • DIN type Pg 11 (for cable dia. of 6 ~ 10mm] Air limiter: S51 series • G1/2 for conduit (Std.) Optional capcon or cordlock available		
MAX. STACKING	Up to 3 Air limiter units		
MASS	1.93kg /with 3 units 1.43kg /2 units 0.93kg /1 unit		
FOR ECONOMITER			
RATED VOLTAGE		• AC 100V 50/60Hz, 110V 60Hz • AC 200V 50/60Hz, 220V 60Hz • DC 24V	
VOLTAGE ALLOWANCE		-15 ~ +10%	
INSULATION CLASS		B	
SOLENOID HOLDING CURRENT (INRUSH)		50Hz	60Hz
		AC 100V	0.102 (0.165) A 0.079 (0.140)A
		AC 200V	0.049 (0.080) A 0.039 (0.068)A
DC 24V		0.27A	
FOR AIR LIMITER			
TYPE OF SWITCH		Small current type	High sensitive type
CURRENT CAPACITY OF SWITCH		AC 100V	1 ~ 100mA 30 ~ 100mA
		AC 200V	NA 20 ~ 100mA
		DC 24V	1 ~ 100mA 35 ~ 100mA

DIMENSIONS

—mm—

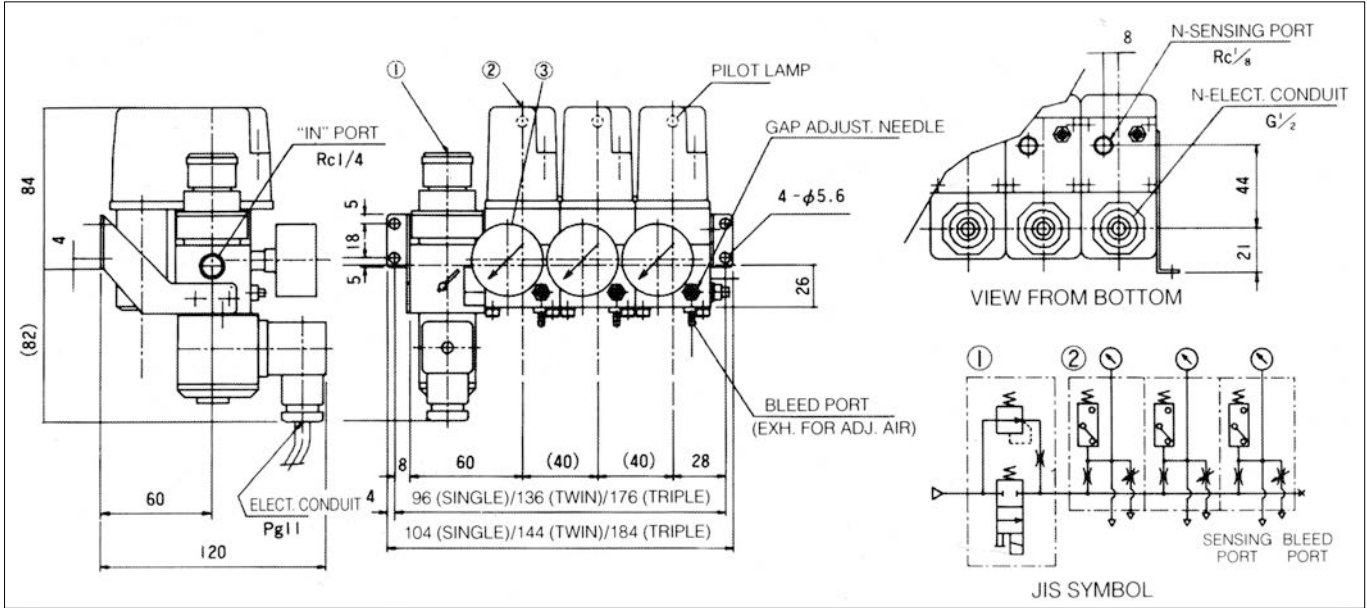

ACCESSORIES

● PRESSURE GAUGE (05676-120)

- $\phi 38$ mm dia., R $1/8$ Center Back Connection
- Mobile Index Marker attached
- Dial Range: 0 ~ 0.4MPa
- Min. Index: 0.02MPa

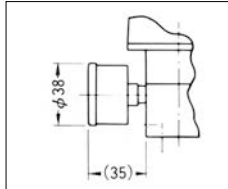

● CAPCON (GE01002)

- Adaptable Dia. of Cabtire Cord : $\phi 4 \sim 12$ mm

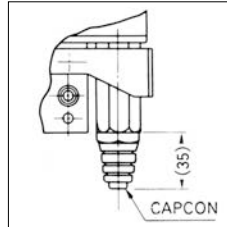

● PRESSURE GAUGE (GAA501020)

- Attached to unit of AOL-112 series
- $\phi 50$ mm dia., R $1/8$ Center Back Connection
- Dial Range: 0 ~ 0.2MPa
- Min. Index: 0.01MPa

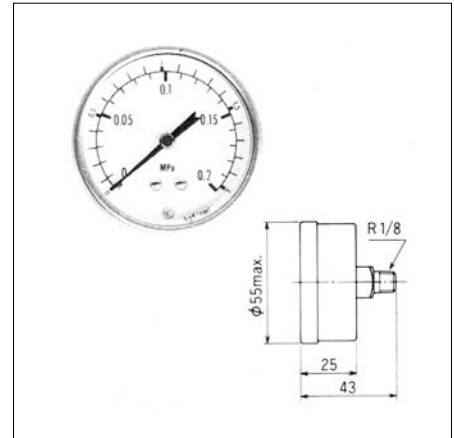

● MANIFOLDING KIT FOR S51

- Contains Stud Bolt, O-ring and Nuts

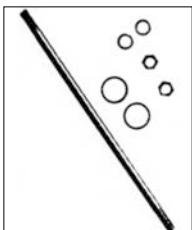

KIT NO.		
QTY. OF UNIT FOR MANIFOLD	KIT NO.	MASS
2	S51-P20-0001	17g
3	S51-P30-0001	24g
4	S51-P40-0001	30g
5	S51-P50-0001	38g

● CORDLOCK (GC10001)

- Adaptable Dia. of Cabtire Cord : $\phi 6 \sim 12$ mm

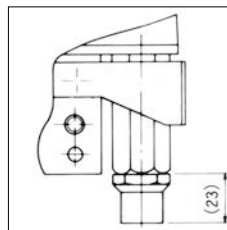

AIR LIMITER

S51 Manifold Panel

SPECIFICATIONS

FLUID	Filtered (5μm) Compressed Air
MAX. INLET PRESSURE	1.0MPa
OPERATING PRESSURE	0.2MPa
PIPE SIZE	Rc ¹ / ₄ (IN port), Rc ¹ / ₈ (Sensing port)
AMBIENT TEMPERATURE	5 ~ 50°C
ECONOMITER	AC100V 50/60Hz, AC110V 60Hz
RATED VOLTAGE FOR AIR LIMITER	AC100V (NEON), AC200V (NEON) DC24V (LED, red)

CODE OF MODEL NO.

C3 - 0570 - ※ □
① ②

① Model No. of Air Limiter to be connected		Remarks Voltage — Switch — Orifice
0	S51-101-1003	DC24V — S — ø0.7mm
1	S51-101-1303	DC24V — S — ø1.2mm
2	S51-101-1001	AC100V — S — ø0.7mm
3	S51-101-1301	AC100V — S — ø1.2mm
4	S51-101-100D	DC24V — H — ø0.7mm
5	S51-101-130D	DC24V — H — ø1.2mm
6	S51-101-100B	AC100V — H — ø0.7mm
7	S51-101-130B	AC100V — H — ø1.2mm
8	S51-101-100C	AC200V — H — ø0.7mm
9	S51-101-130C	AC200V — H — ø1.2mm

NOTE 1) Output Switch type
S : Small electric current type
H : High sensitive type
2) Orifices are DIMS of built-in metering orifice dia.

REFER TO THE DRAWING

NAME	MODEL NO.	REMARKS
1 FILTER	F73G-2BN-AD1	5μm Element, Auto-drain type
2 REGULATOR	R42-201-4001	with Pressure Gauge of φ 50 dia.
3 ECONOMITER	MVS214-02KS-07	AC100V 50/60Hz, AC110V 60Hz
4 AIR LIMITER	S51-101-1※0※	See Code of Model No.

② Number of connecting S51 Air limiter	
1	Single
2	2 units
3	3 Units

DIMENSIONS —mm—

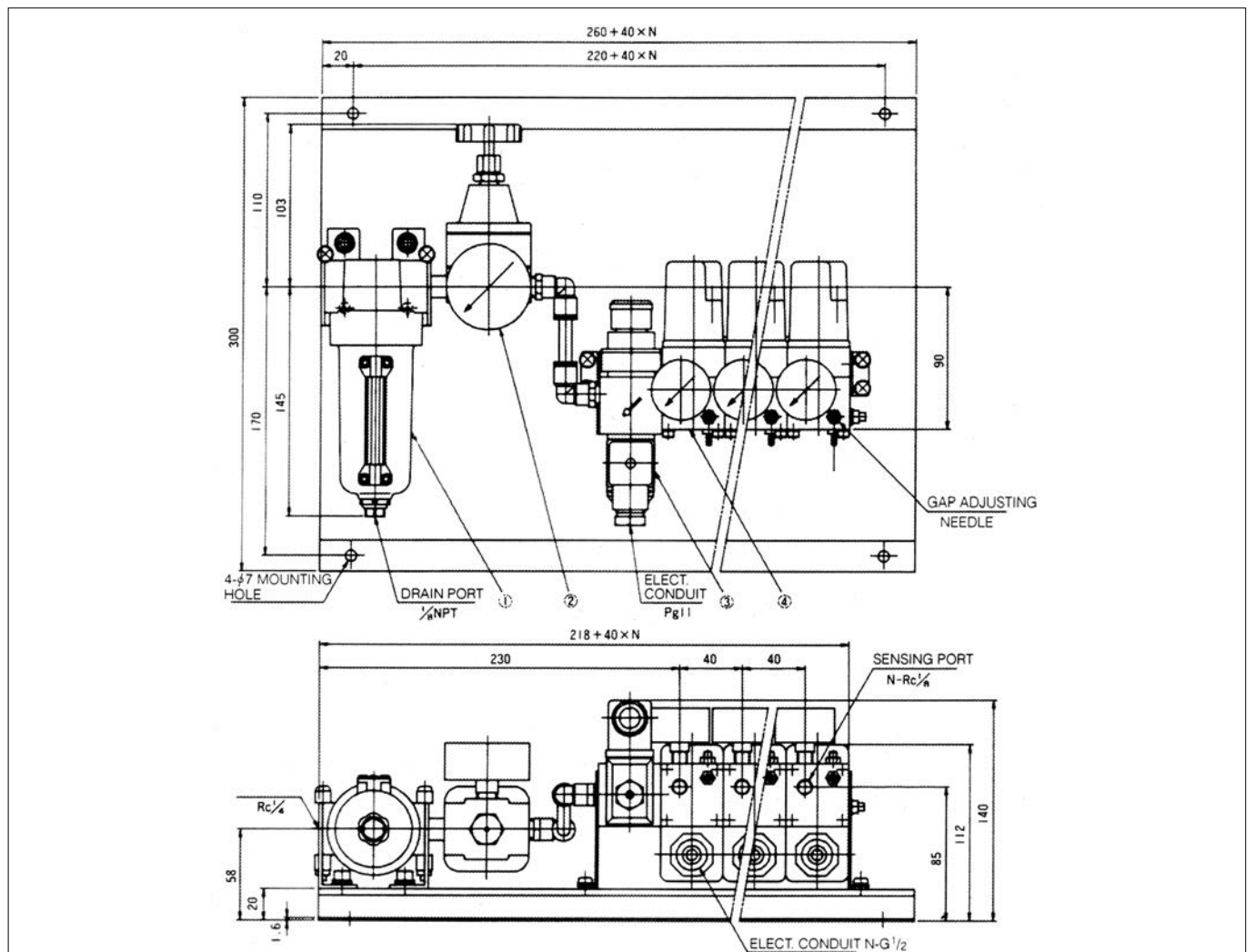

AIR LIMITER

AOL-112 SERIES



GAUGE ON OPTION

SPECIFICATIONS

FLUID	Filtered Clean Compressed Air (by 5μm rated filter), No oiliness	
PIPE SIZE	Rc ¹ / ₄ ; Both IN/Supply port and OUT/Sensing port	
AMBIENT TEMPERATURE	5 ~ 60°C	
OPERATING PRESSURE	0.05 ~ 0.2MPa	
SENSING GAP RANGE	0.01 ~ 0.6mm	
SENSING ACCURACY	±0.01mm for Gap: 0.01 ~ 0.2mm, ±0.03 for gap: 0.2mm ~	
SENSING PRESSURE RANGE	0.01 ~ 0.1MPa Adjustable	
CONTACT TYPE OF SWITCH	1c (Single Pole, Double Throw)	
AVAILABLE ELECTRIC CURRENT CAPACITY OF OUTPUT SWITCH	Small electric current type switch (for programable controller)	<ul style="list-style-type: none"> • 1 ~ 100mA/AC100V • 3 ~ 100mA/DC24V
	High sensitive type switch	<ul style="list-style-type: none"> • 30 ~ 100mA/AC100V • 20 ~ 100mA/AC200V • 35 ~ 100mA/DC24V
OPERATION PILOT LAMP	Option (Neon lamp or LED lamp/clear, green or red)	
MASS	1.9kg	

MODEL NOS. OF SINGLE UNIT

Pilot lamp & Rated voltage	Small current type (AC100V, DC24V)	High sensitive type (AC100V, 200V, DC24V)	Pilot lamp & wiring (Darkness leakage current)	
No pilot lamp	AOL-112A	AOL-112	No lamp	<ul style="list-style-type: none"> • COM is connected to NO at pressure increasing.
AC100V with pilot lamp	AOL-112AST1	AOL-112ST1	Neon (0.6mA)	<ul style="list-style-type: none"> • Lamp turns off at pressure increasing & Load is activated. • Lamp turns on by changing wiring from NO to NC.
AC200V with pilot lamp	— (Not available)	AOL-112ST2		
DC24V with pilot lamp	AOL-112AST3	AOL-112ST3	LED (20mA)	<div style="display: flex; justify-content: space-around;"> <div style="text-align: center;"> <p>AOL-112(A)S*3</p> <ul style="list-style-type: none"> • Pressure increasing turns on lamp & activates Load. </div> <div style="text-align: center;"> <p>AOL-112(A)S*3P</p> <ul style="list-style-type: none"> • Pressure decreasing turns on lamp & activates Load. </div> </div>
	AOL-112AST3P	AOL-112ST3P		

◎ Units with pilot lamp listed above are furnished with clear/white color lamp. Other lamp color can be specified by replacing ST with SG (green) or SR (red).

◎ Standard models with pilot lamp rated DC24V are of ⊖COM wiring. ⊕COM wiring is available by interchanging wiring terminal of pilot lamp to invert electric polarity of LED.

HOW TO ORDER

AOL - 112 x
 ① ② ③

② Pilot lamp

NIL without pilot lamp (Std.)
 S** with pilot lamp
 (See below mark list)

③ Number of AOL-112 units for Manifold

NIL Single unit
 2~8 Manifolding unit number

Marks of S** for unit with Pilot Lamp

Color	Voltage		
	AC100V	AC200V	DC24V
Transparent	ST1	ST2	<ul style="list-style-type: none"> • ST3 • ST3P
Green	SG1	SG2	<ul style="list-style-type: none"> • SG3 • SG3P
Red	SR1	SR2	<ul style="list-style-type: none"> • SR3 • SR3P

① Type of Switch

NIL High sensitive type
 A Small electric current type (for programable controller)

* Models of small current type switch with pilot lamp are for AC100V or DC24V, models for AC200V are not available.

* On "S*1", "S*2" and "S**P" model, pilot lamp is turned off at pressure increase.
 On S*3" model, pilot lamp is turned on at pressure increase.

DIMENSIONS —mm—

SINGLE

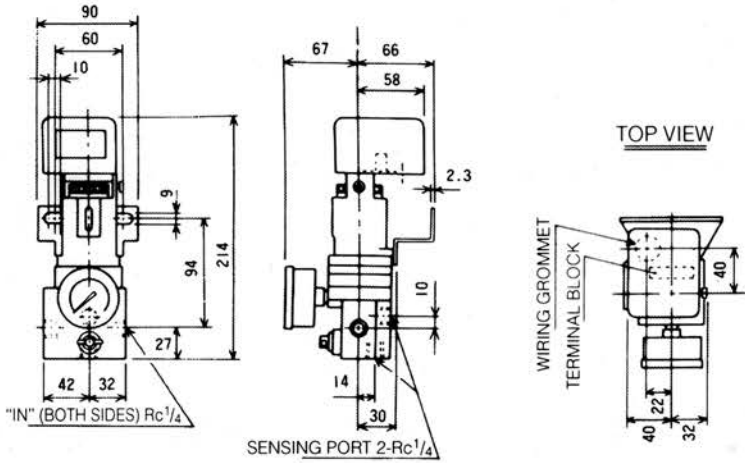

NOTE : PRESSURE GAUGE AND BRACKET ARE STANDARD ITEM.

ADJUSTMENT OF AOL-112 SERIES.

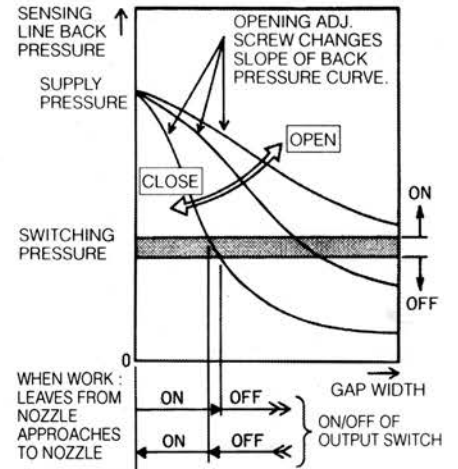

MANIFOLD

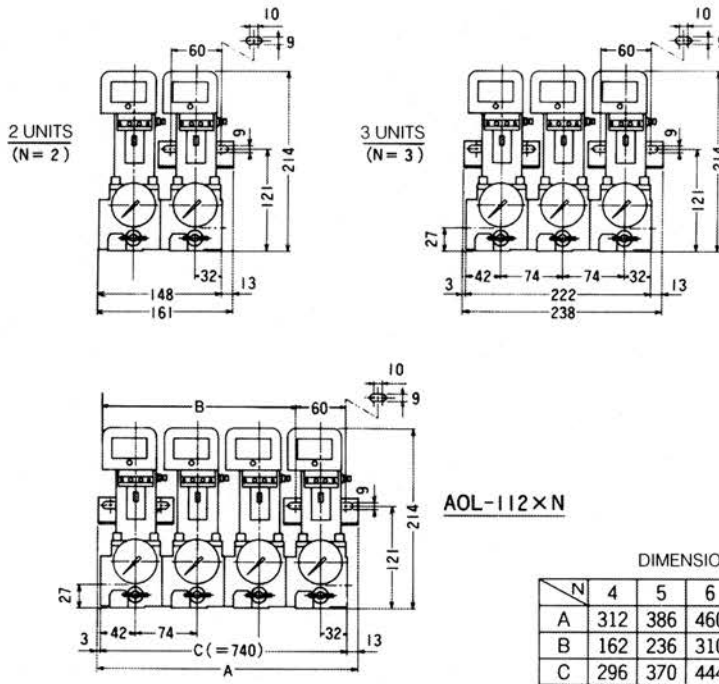

DIMENSIONS

N	4	5	6	7	8
A	312	386	460	534	608
B	162	236	310	384	458
C	296	370	444	518	592

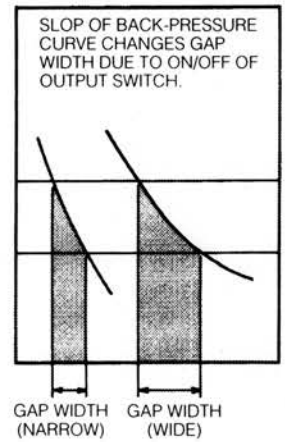

- ABOUT 1/2 OFF SUPPLY PRESSURE IS NORMALLY SET ON SWITCHING OF OUTPUT SWITCH. (MAX. SWITCHING PRESSURE SETTING IS 0.1MPa)
- IF BACK PRESSURE CURVE DOES NOT MEET WITH SWITCHING PRESSURE OF OUTPUT SWITCH, REMAINS ON STATE. AT THIS CASE READJUST SUPPLY PRESSURE AND OPENING ADJ. SCREW.

WIRING DIAGRAM ... CONNECTION ELECTRICAL LOAD TO SWITCH OFF AOL-112 UNIT WITH PILOT LAMP.

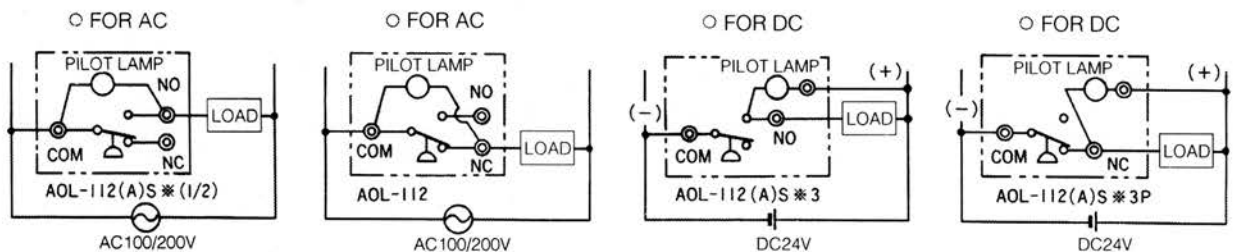

AC100/200V
PRESSURE DECREASING
TURNS ON PILOT LAMP AND
TURNS OFF ELECT. LOAD.

AC100/200V
PRESSURE INCREASING
TURNS ON PILOT LAMP AND
TURNS OFF ELECT. LOAD.
(CHANGE OF WIRE
CONNECTION OF PILOT LAMP
IS NEEDED.)

DC24V
PRESSURE INCREASING
TURNS ON PILOT LAMP AND
TURNS ON ELECT. LOAD.

DC24V
PRESSURE DECREASING
TURNS ON PILOT LAMP AND
TURNS OFF ELECT. LOAD.

NOTE : STANDARD DC24V MODEL WITH PILOT LAMP ARE OF ⊖COM WIRING. IF ⊕COM TYPE REQUIRED, INTERCHANGE WIRING TERMINAL OF THE PILOT LAMP.

AIR LIMITER

AOL-112 Manifold Panel

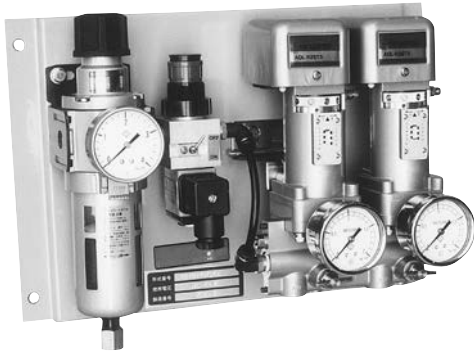

SPECIFICATIONS

FLUID	Filtered (5µm) Compressed Air
MAX. INLET PRESSURE	1.0MPa
OPERATING PRESSURE	0.2MPa max.
PIPE SIZE	Rc ¹ / ₄ for IN port, Rc ¹ / ₈ for Sensing port
AMBIENT TEMPERATURE	5 ~ 50°C
RATED VOLTAGES OF ECONOMITER	AC100V, AC200V or DC24V (Allowable Fluctuation: -5 ~ +10%)
AIR LIMITER	
SENSING GAP	0.01 ~ 0.2 (±0.01) mm 0.2 ~ 0.6 (±0.03) mm
PILOT LAMP & RATED VOLTAGE	Neon Lamp for AC100V/AC200V LED Lamp for DC24V
OUTPUT OF SWITCH	max. 100mA/capacity, 1c type contact

© See details at pages of each unit.

CODE OF MODEL NO.

C03 - 0210

※	S	※	※	X	N	□
---	---	---	---	---	---	---

① ② ③ ④

① Switch of Air limiter	
NIL	High sensitive type
A	Small electric current type

② Lamps & Voltage of Air limiter			
Color	Clear	Green	Red
AC100V	T1	G1	R1
AC200V	T2	G2	R2
DC24V	T3	G3	R3

③ Number (N) of AOL-112 units for Manifold	
1	1
2	2
3	3

④ Rated Voltage of Economitor	
1	AC100V
2	AC200V
3	DC24V

Small electric current type Air limiter with pilot lamp is only available AC100V and DC24V

DIMENSIONS -mm-

IN PORT Rc¹/₄

4-φ9

94

244

145

19

25

38.5

156.5

74 × (N-1)

B

A

DRAIN PORT NPT¹/₈

ELECT. CONDUIT. Pg11

SENSING PORT Rc¹/₈

GRAPHICAL DIAGRAM

② ③ ④

①

SENSING POR

OPERATION LAMP & SWITCH TERMINALS

For AC (AC100V, AC200V)

NEON

(BLK.) COM

(WHT.) NO

(RED.) NC

For DC (DC24V)

LED

(-) COM

(+) NO

(WHT.) NC

NO.	NAME	MODEL NO.	QTY	REMARK
1	FILTER/REGULATOR		1	with φ50 gauge
2	ECONOMITER	MVS-214-02S-07	1	
3	AIR LIMITER	AOL-112※S※※	N	
4	PANEL		1	t 1.6mm Panel

DIM	A	B
Single	290	270
2 Units	360	340
3 Units	440	420



CODE OF MODEL NO.

MVS-214-02 S B-07 AC 100V

① ②

① Accessory

NIL (Standard)
B with Bracket & Panel Nut

② Rated Voltage

AC 100V	AC 100V 50/60Hz, 110V 60Hz
AC 200V	AC 200V 50/60Hz, 220V 60Hz
DC 24V	DC 24V

(Model for stack mounting is available by MVS-214-02KS-07)

Detection Nozzles are always cleaned from Dust, Coolant and Undesirable Matters around the Nozzles.

- Soft breeze air for purge protects nozzles from intrusion of dust and coolant.
- At the detection operation of the work, normal air pressure for detection is supplied by activation of solenoid valve section.
- Provides reliability for the detection system with minimum air consumption of energy saving.
- Pilot lamp and surge voltage suppresser are standard attached items.

SPECIFICATIONS

FLUID	Filtered Compressed Air by 5 μ m Filter Element (No oiliness)		
OPERATING PRESSURE	0.2MPa max.		
AMBIENT TEMPERATURE	5 ~ 50°C		
EFFECTIVE AREA	5mm ²		
PURGING FLOW RANGE	0.6 ~ 1.6dm ³ /min. (ANR) (Equivalent to pressure adjustment of built-in regulator: 0.007 ~ 0.05MPa)		
MANUAL OPERATOR	Lever, 2 Position		
RATED VOLTAGE	<ul style="list-style-type: none"> • AC 100V 50/60Hz, 110V 60Hz • AC 200V 50/60Hz, 220V 60Hz • DC 24V 		
ELECTRIC CONNECTOR	<ul style="list-style-type: none"> • DIN: Pg 11 • with Pilot Lamp & Surge Suppressor 		
VOLTAGE ALLOWANCE	-15 ~ +10%		
INSULATION CLASS	B		
SOLENOID HOLDING CURRENT (Inrush)		50Hz	60Hz
	AC 100V	0.102 (0.165) A	0.079 (0.140) A
	AC 200V	0.049 (0.080) A	0.039 (0.068) A
	DC 24V	0.27A	
MASS	0.45kg		

*This unit is impossible to be combined with Air Limiter operated by supply pressure of 0.3MPa

DIMENSIONS -mm-

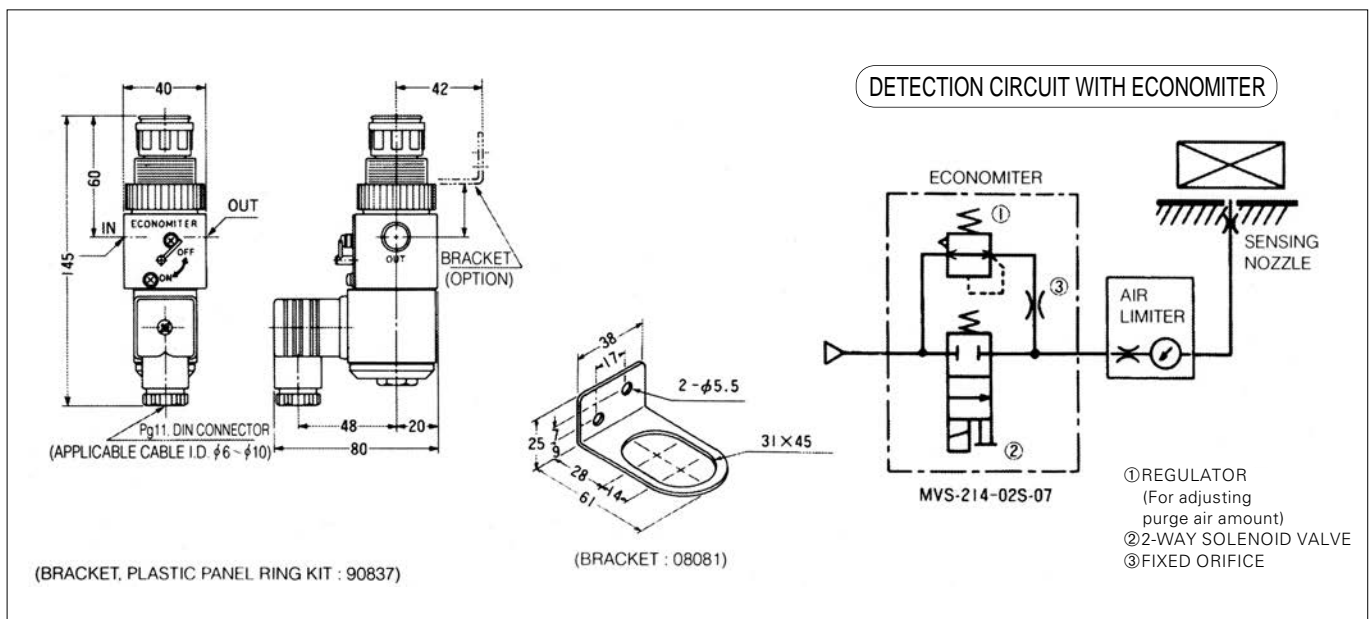

AIR FILTER

NAF-500XL SERIES (Rc1¹/₄~Rc3)

MAIN LINE AIR FILTER



SPECIFICATIONS

FLUID	Compressed Air
MAX. INLET PRESSURE	1.0MPa
AMBIENT TEMPERATURE	5 ~ 60°C
FILTER ELEMENT	74µm
DRAINAGE	Manual or Automatic

* Minimum operating pressure for Automatic drain model is 0.1MPa.

MODEL NOs. & OTHER

Pipe Size	MODEL NUMBER	Drainage	Drain Capacity (cm ³ /at each operation)	Mass (kg)
Rc1 ¹ / ₄	NAF-512XL	Manual	Manual Drain: 800 Automatic Drain: 3.5 at 0.5MPa, by SDU-202	11
	NAF-512XLD	Automatic		
Rc1 ¹ / ₂	NAF-514XL	Manual		
	NAF-514XLD	Automatic		
Rc2	NAF-520XL	Manual	Manual Drain: 1200 Automatic Drain: 3.5 at 0.5MPa	21
	NAF-520XLD	Automatic		
Rc3	AF-530Y	Manual	Manual Drain:2500	55

NOTE 1. AF-530Y : METAL CYLINDER WITH LEVEL GAUGE.
 2. AF-530Y : ORDER PRODUCTION.
 3. FOR AUTOMATIC DRAIN, MIN. OPERATION PRESSURE IS OVER 0.10MPa.

HOW TO ORDER

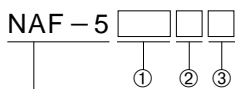

AIR FILTER NAF/AF-500 SERIES

① Pipe size

12	Rc1 ¹ / ₄
14	Rc1 ¹ / ₂
20	Rc2
30	Rc3 (order production)

② Cylinder

XL	Metal cylinder /with Plastic Level gauge (Std.)
XLS	Metal cylinder /with Glass level gauge

③ Drainage

NIL	Manual drain (Std.)
D	Automatic drain (packaged with SDU-202; Self-drain unit)

DIMENSIONS -mm-

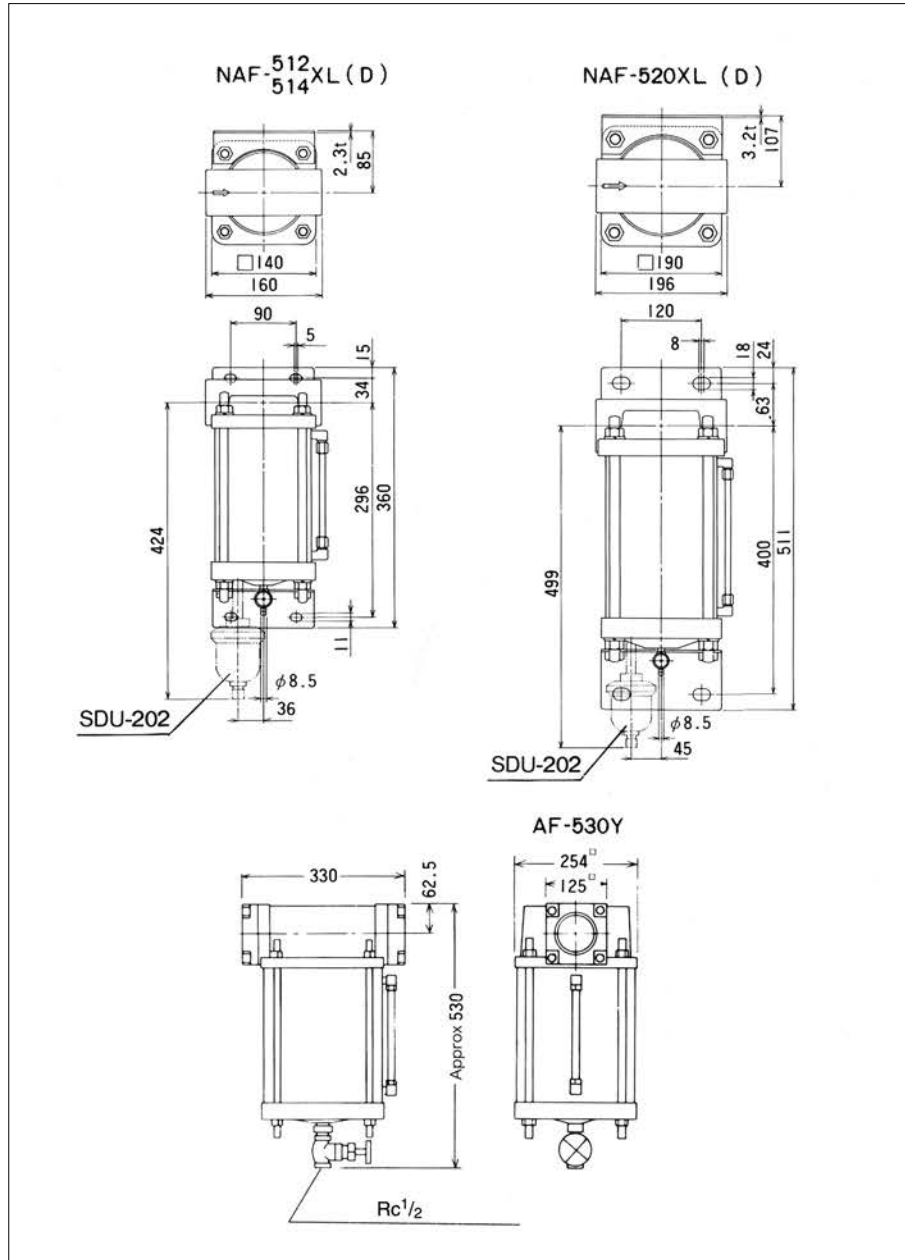

FLOW CHARACTERISTIC CURVE

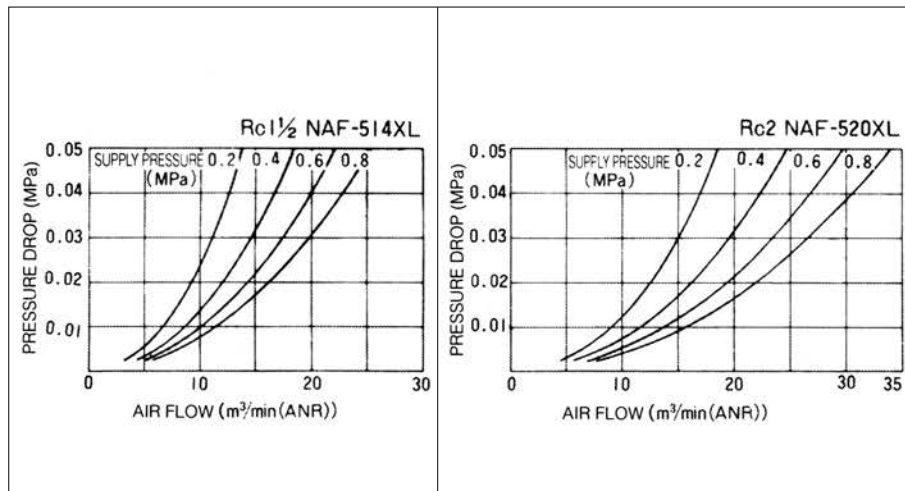

AIR FILTER

NAF-600 SERIES (Rc¹/₄~Rc1)



SPECIFICATIONS

FLUID	Compressed Air
MAXIMUM INLET PRESSURE	1.0MPa
AMBIENT TEMPERATURE	5 ~ 60°C
FILTER ELEMENT	74µm (Std.), 25µm or 5µm
DRAINAGE	Manual or Automatic
BOWL	Transparent Polycarbonate Bowl with Bowl Guard, or Metal Bowl

MODEL NUMBERS & OTHERS

Pipe Size	MODEL NUMBER		Mass (kg)	Drain Capacity
	Manual Drain	Automatic Drain		
Rc ¹ / ₄	NAF-602	NAF-602D	0.8	Manual Type; • max. 72cm ³ for NAF-602~604
Rc ³ / ₈	NAF-603	NAF-603D		
Rc ¹ / ₂	NAF-604	NAF-604D		
Rc ³ / ₄	NAF-606	NAF-606D	3.0	Automatic Type; • 25~28cm ³
Rc1	NAF-610	NAF-610D		

HOW TO ORDER

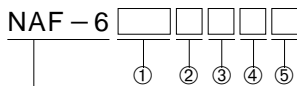

AIR FILTER
NAF-600 SERIES

① Pipe size

02	Rc ¹ / ₄
03	Rc ³ / ₈
04	Rc ¹ / ₂
06	Rc ³ / ₄
10	Rc1

② Bowl

NIL	Transparent Bowl with Bowl Guard
XLS	Metal Bowl with Glass Sight Gauge

③ Drainage

NIL	Manual Drain (Std.)
D	Automatic Drain

④ Filter Element

NIL	74µm
M25	25µm
M5	5µm

⑤ Bracket

NIL	without Bracket (Std.)
B	with Bracket

DIMENSIONS -mm-

NAF-602 ~ 604 (STD.) (D)

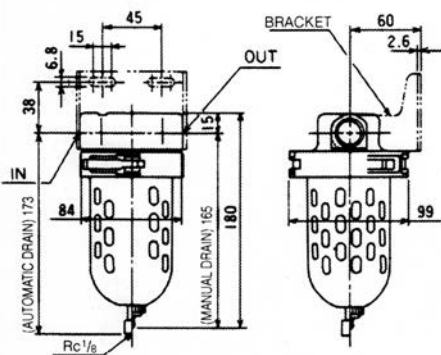

NAF-602 ~ 604X (XL, XLS) (D)

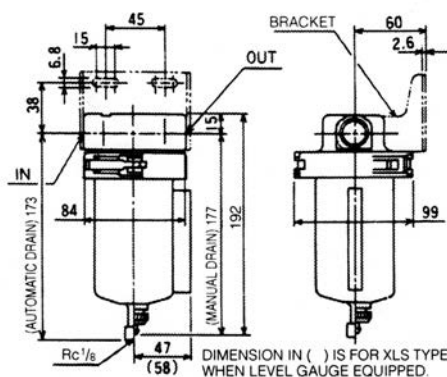

NAF-606, 610 (STD.) (D)

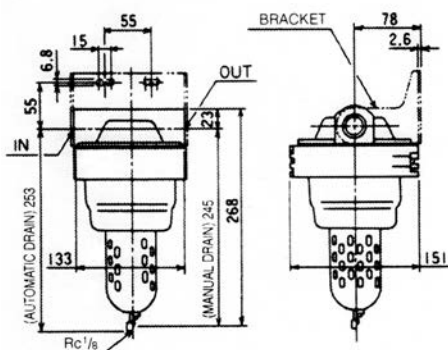

NAF-606, 610X (XL, XLS) (D)

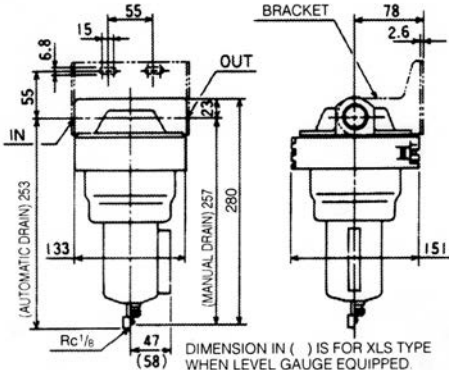

FLOW CHARACTERISTICS CURVE

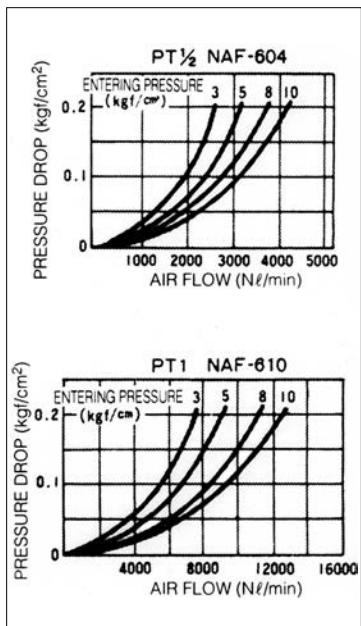

SELF-DRAIN UNIT

SDU-200 (Rc¹/₄)
SDU-300XL (Rc³/₄)

SDU-202

- Compact Model



SDU-306XL

- High Capacity Model
- Positive Drainage through Solenoid Valve
- No Air Loss at Draining



MODEL NOS. & SPECIFICATION

MODEL NUMBERS		SDU-202	SDU-306XL
PIPE SIZES	DRAIN INLET	Rc ¹ / ₄	Rc ³ / ₄
	DRAIN OUTLET	Rc ¹ / ₈	Rc ¹ / ₂
OPERATING PRESSURE		0.1 ~ 1.0MPa	0.05 ~ 0.7MPa
AMBIENT TEMPERATURE		5 ~ 60°C	5 ~ 50°C
DRAINAGE CAPACITY		3.5cm ³ @0.5MPa	200cm ³ @0.7MPa
RESERVOIR		Metal Bowl	Metal Cylinder with level gauge
DRAINAGE OPERATION		Float & Air Pressure	Float & Solenoid Valve
MASS		0.44kg	5.3kg
SOLENOID			<ul style="list-style-type: none"> • AC 100V 50/60Hz, 110V 60Hz • AC 200V 50/60Hz, 220V 60Hz
RATED VOLTAGE		-	
VOLTAGE ALLOWANCE		-	-15 ~ +10%
INSULATION		-	Class B
ELECTRIC CURRENT OF SOLENOID:			50Hz 60Hz
HOLDING (INRUSH)		AC 100V	0.104A (0.126A) 0.084A (0.10A)
		AC 200V	0.05A (0.06A) 0.041A (0.05A)

*1. SDU-306XL is required to specify operating voltage at end of model no.
 *2. SDU-202 with bracket can specify by adding B at end of model no.

DIMENSIONS -mm-

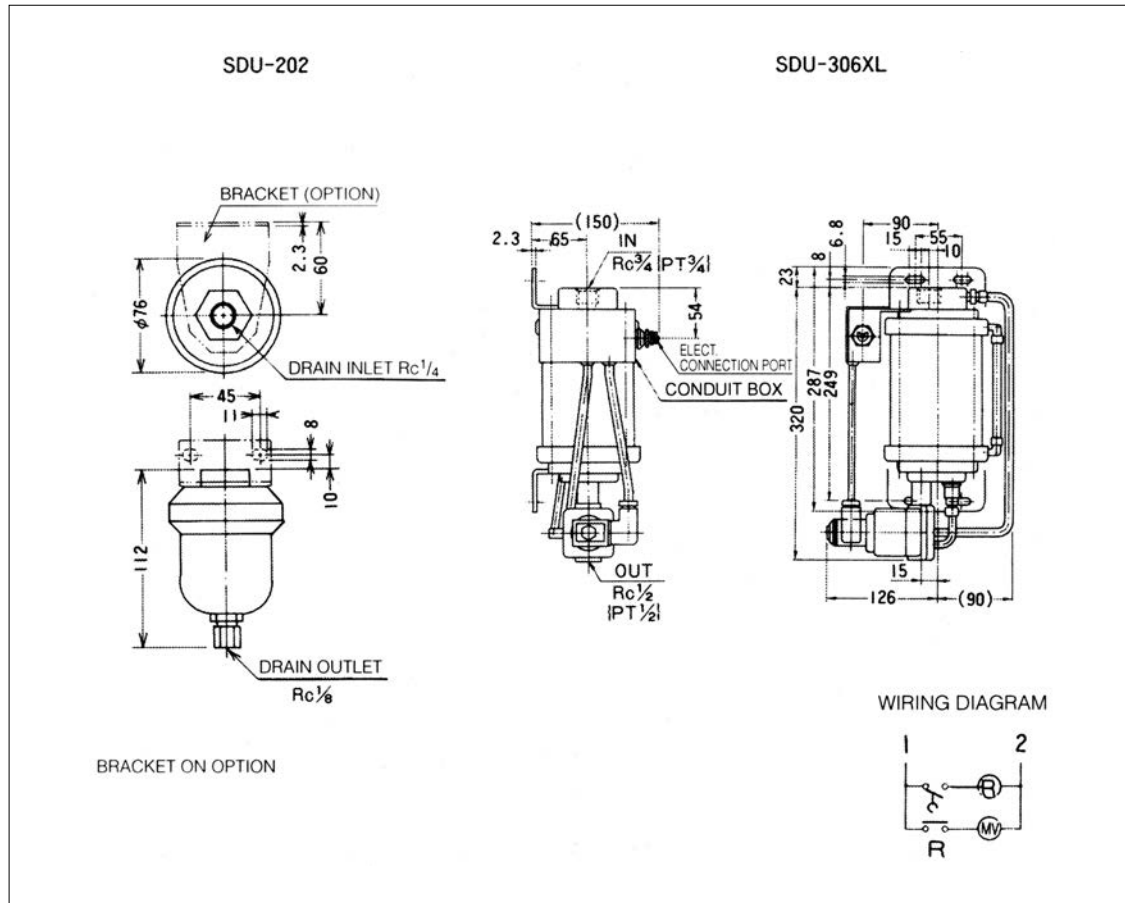

AIR REGULATOR

R31 SERIES (Rc¹/₈, Rc¹/₄)

COMPACT TYPE



GAUGE ON OPTION

SPECIFICATIONS

FLUID	Filtered Compressed Air
MAXIMUM INLET PRESSURE	1.0MPa
AMBIENT TEMPERATURE	5 ~ 60°C
RELIEF	Relieving and Non-relieving
ADJUSTMENT	Snap lock knob type (one touch lock)

BASIC MODEL NOS. & OTHERS

Pipe Size	MODEL NUMBER		Adjusting Pressure Range	Gauge Port	Mass (kg)
	Relieving	Non-relieving			
Rc ¹ / ₈	R31-100-0000	R31-100-0100	0.02 ~ 0.7MPa	Rc ¹ / ₈ (2 places)	0.18
	R31-100-C000	R31-100-C100	0.01 ~ 0.35MPa		
	R31-100-B000	R31-100-B100	0.007 ~ 0.07MPa		
Rc ¹ / ₄	R31-200-0000	R31-200-0100	0.02 ~ 0.7MPa		
	R31-200-C000	R31-200-C100	0.01 ~ 0.35MPa		
	R31-200-B000	R31-200-B100	0.007 ~ 0.07MPa		

HOW TO ORDER

R 31 - 200 - 0000

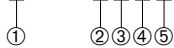

COMPACT AIR REGULATOR R31 SERIES
BASIC BODY SIZE: ¹/₈B

① Pipe size

- 1 Rc¹/₈
- 2 Rc¹/₄

② Adjusting Pressure Range

- 0 0.02 ~ 0.7MPa
- B 0.007 ~ 0.07MPa
- C 0.01 ~ 0.35MPa

③ Relief

- 0 Relieving type
- 1 Non-relieving type

④ Accessory

- 0 No Accessory (Std.)
- B Bracket (with Plastic panel nut)
- R Panel nut (Aluminium)
- 2 Panel nut (Plastic)

⑤ Gauge

- 0 without Gauge (Std.)
- 1 with Gauge of center back connection

DIMENSIONS -mm-

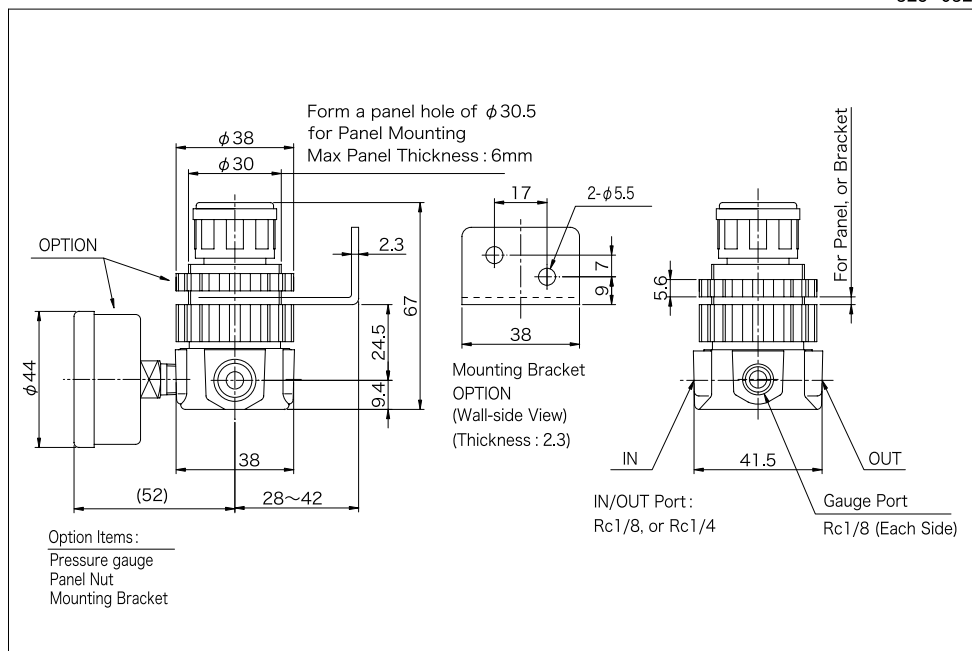

(By Dwg 3J-xxxx, -xxxx)

CHARACTERISTIC CURVE

ADJUSTMENT CHARACTERISTIC CURVE

Rc¹/₄R31-200-0000
(0.02~0.70MPa)

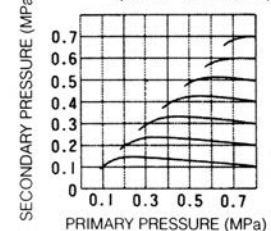

FLOW CHARACTERISTIC CURVE

Rc¹/₄R31-200-0000
(0.02~0.70MPa)

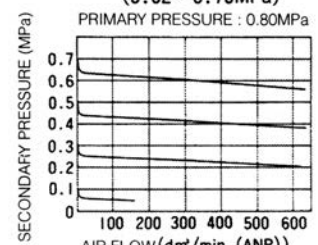

AIR REGULATOR

RK-1206 SERIES (Rc^{3/4})

MANIFOLD REGULATOR

SPECIFICATIONS



GAUGE ON OPTION

FLUID		Filtered Compressed Air
MAXIMUM INLET PRESSURE		1.0MPa
AMBIENT TEMPERATURE		5 ~ 60°C
ADJUSTING PRESSURE RANGE		<ul style="list-style-type: none"> •0.02 ~ 0.8MPa •0.01 ~ 0.4MPa
RELIEF		Relieving
PIPE SIZE	Inlet port (common)	Rc ^{3/4} at both sides
	Outlet port	Rc ^{1/2} at each regulator
	Gauge port	Rc ^{1/8} at each regulator

SELECTING REGULATORS for MANIFOLD

Specify kinds of regulator and accessory for forming manifold unit by marks of the following table. Regulator array of manifold can be directed with order of marks from left side of manifold with seeing manifold from following direction. It is the outlet port is locating towards this side, on the condition of locating pressure adjustment section towards upside.

Marks	Model No. for Each Valve	Adjusting Handle	Pressure Range
1	RV2-400-RNEBK	Knob (Standard)	0.01 ~ 0.4MPa
2	RV2-400-RNLBK		0.02 ~ 0.8MPa
3	RV2-401-RNEBK	T handle	0.01 ~ 0.4MPa
4	RV2-401-RNLBK		0.02 ~ 0.8MPa

Marks	Accessories	usage
P	Supply Block	Attached for Additional supply port
Y	Separator	Available for dual (IN) supply pressure by separating the set of manifold regulator
S	Spacer	Makes enough clearance between each regulator
C	Intermediate Supporter	Supports the set of manifold regulator firmly at mid position

*Order the pressure gauge at option.

HOW TO ORDER

RK - 1206 x -

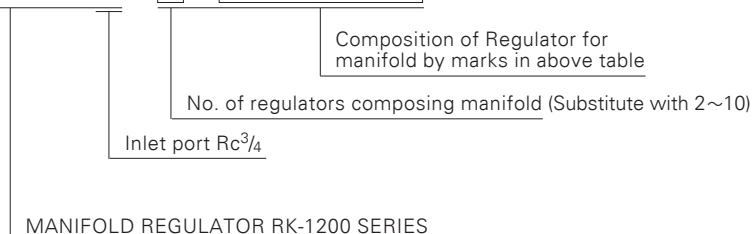

BASIC DIMENSIONS
without attaching accessories

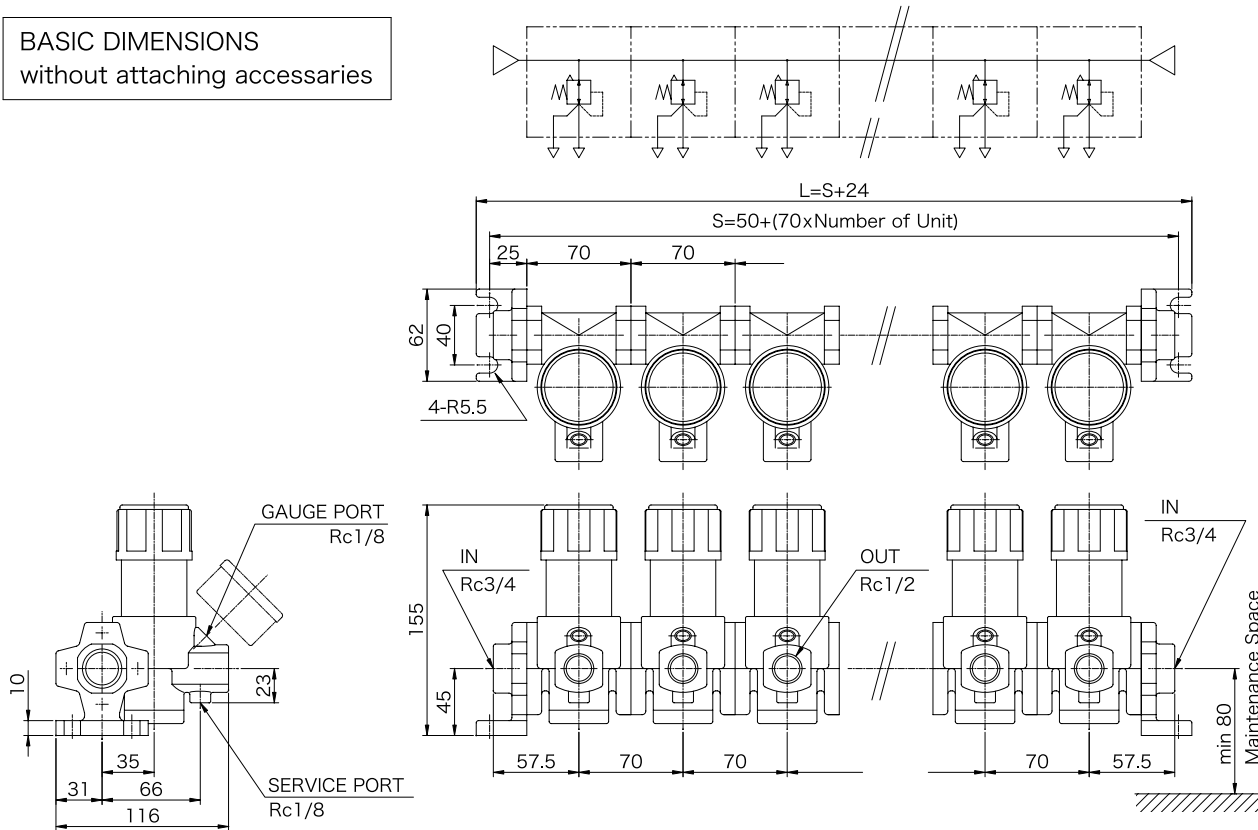

Dimensions with Accessories

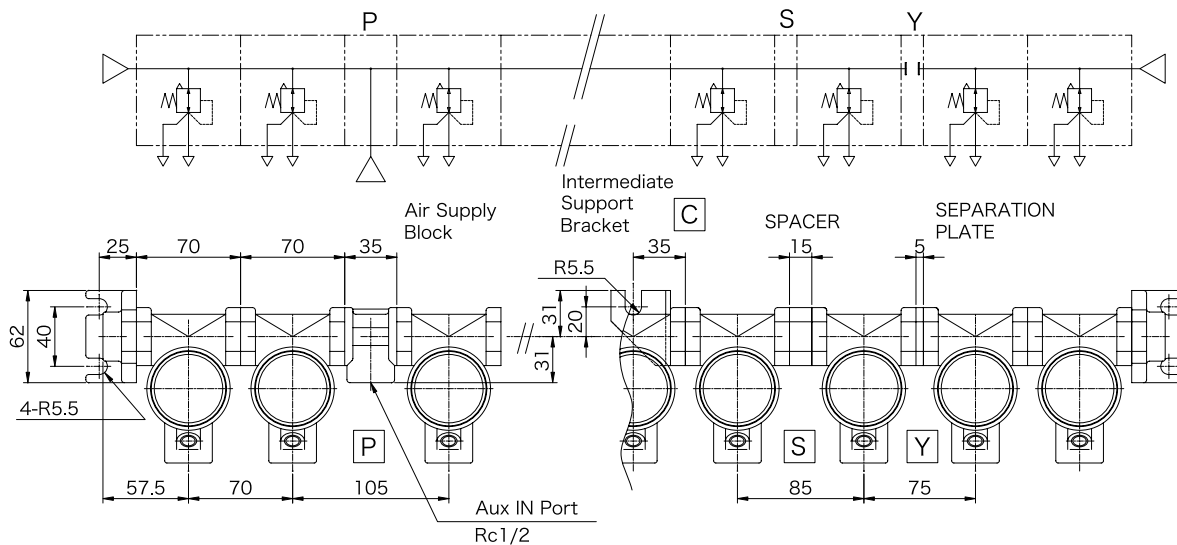

CHARACTERISTIC CURVE

ADJUSTING CHARACTERISTIC CURVE

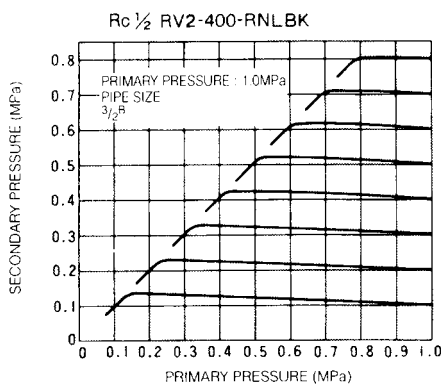

AIR FLOW CHARACTERISTIC CURVE

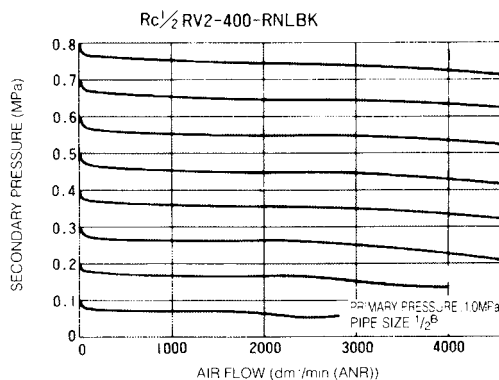

AIR REGULATOR

NRV-300/200 SERIES (Rc¹/₄~Rc1)



GAUGE ON OPTION



GAUGE ON OPTION

SPECIFICATIONS

SERIES	NRV-300	NRV-200
FLUID	Filtered Compressed Air	
MAXIMUM INLET PRESSURE*	1.0MPa	
AMBIENT TEMPERATURE	5 ~ 60°C	
OPERATION	Directly operated by spring	
ADJUSTING PRESSURE RANGE	<ul style="list-style-type: none"> •0.02 ~ 0.8MPa (Std.) •0.01 ~ 0.3MPa •0.01 ~ 0.1MPa •0.1 ~ 1.6MPa * 	
RELIEF	Relieving	Non-relieving

*Max Inlet pressure: 2.8MPa for units of ~1.6MPa range.

*0.1~1.6MPa range is available for units of pipe size of 1/4, 3/8 and 1/2.

BASIC MODEL NOS. & OTHERS

Pipe Size	MODEL NUMBER		Gauge Port	Mass (kg)
	Relieving	Non-relieving		
Rc ¹ / ₄	NRV-302	NRV-202	Rc ¹ / ₈ (2 places)	1.2
Rc ³ / ₈	NRV-303	NRV-203		1.4
Rc ¹ / ₂	NRV-304	NRV-204		2.9
Rc ³ / ₄	NRV-306	NRV-206		2.7
Rc1	NRV-310	NRV-210		

HOW TO ORDER

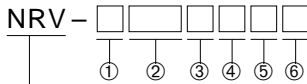

AIR REGULATOR NRV-300/200 SERIES

① Series

2	NRV-200 (Non-relieving type)
3	NRV-300 (Relieving type)

② Pipe size

02	Rc ¹ / ₄
03	Rc ³ / ₈
04	Rc ¹ / ₂
06	Rc ³ / ₄
10	Rc1

③ Adjustment

NIL	T handle (Std.)
P	Panel mount with hand wheel

④ Adjusting Pressure Range

NIL	0.02 ~ 0.8MPa (Std.)
K3	0.01 ~ 0.3MPa
K1	0.01 ~ 0.1MPa
K16	0.1 ~ 1.6MPa

⑤ Gauge

NIL	without Gauge (Std.)
LT	with Gauge of center back connection

⑥ Bracket

NIL	without Bracket (Std.)
B	with Bracket

DIMENSIONS

—mm—

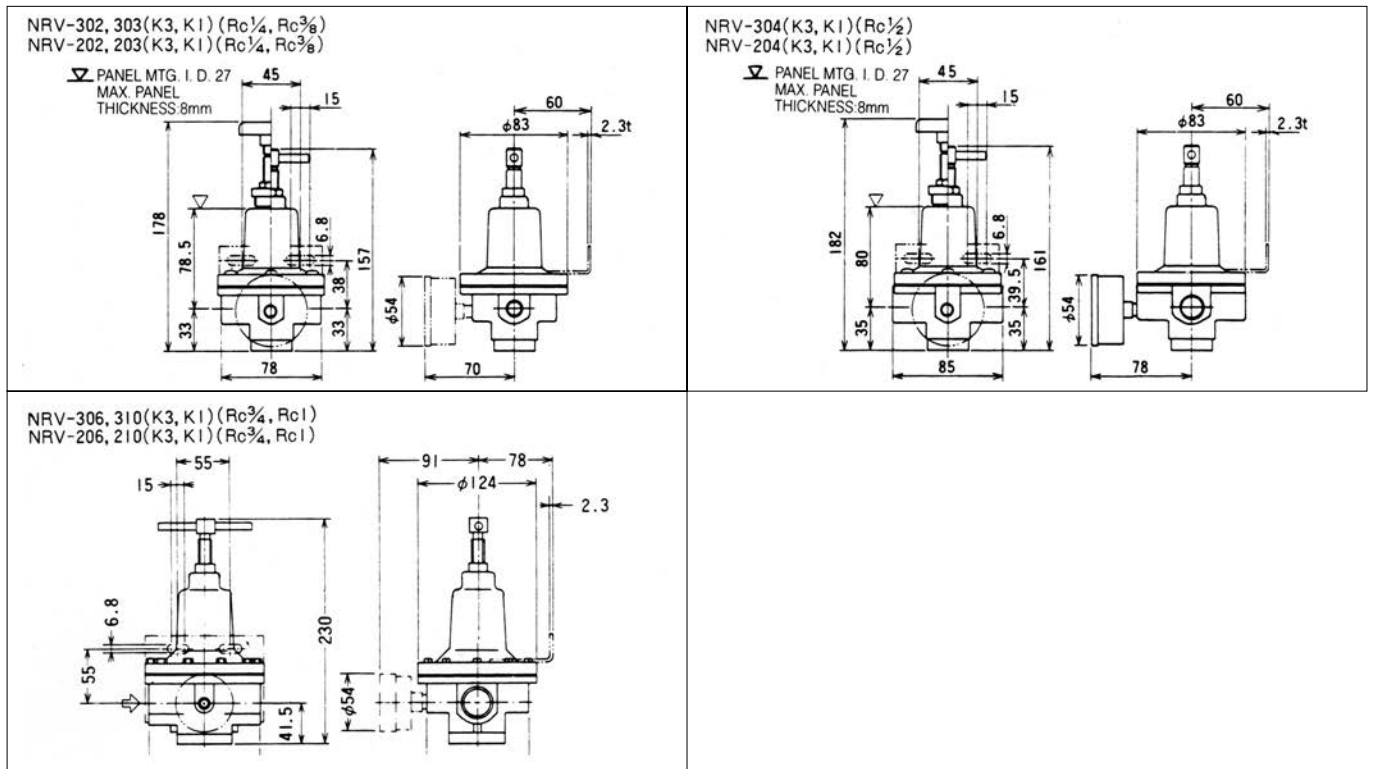

CHARACTERISTIC CURVE

ADJUSTING CHARACTERISTIC CURVE
Rc^{3/8} NRV-303

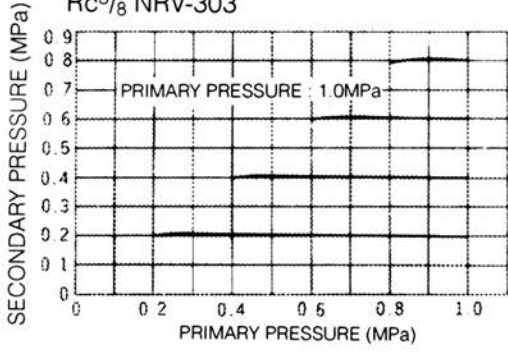

ADJUSTING CHARACTERISTIC CURVE
Rc^{1/2} NRV-304

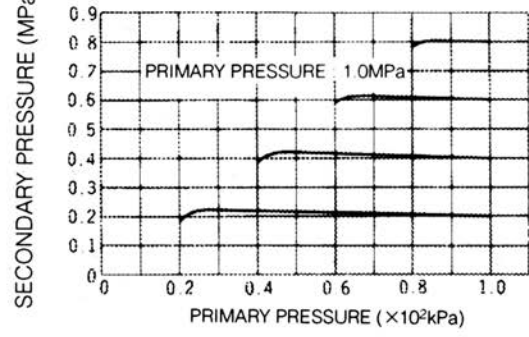

FLOW CHARACTERISTIC CURVE
Rc^{3/8} NRV-303

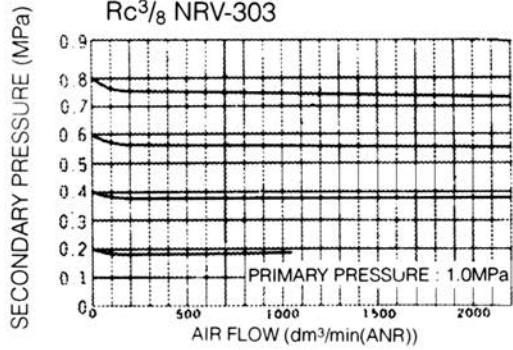

FLOW CHARACTERISTIC CURVE
Rc^{1/2} NRV-304

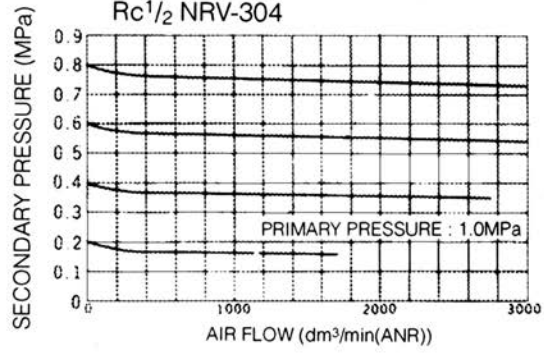

FLOW CHARACTERISTIC CURVE
Rc^{3/8} NRV-303K3

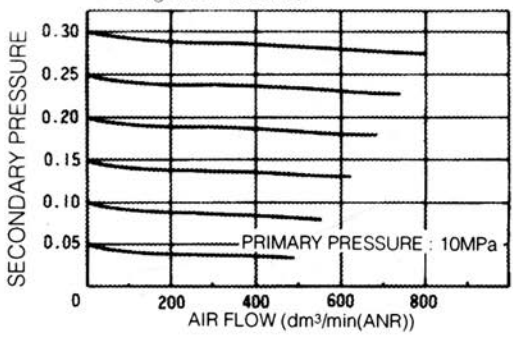

FLOW CHARACTERISTIC CURVE
Rc^{1/2} NRV-304K3

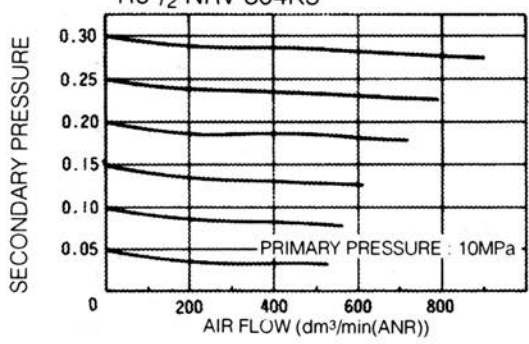

FLOW CHARACTERISTIC CURVE
Rc^{3/8} NRV-303K1

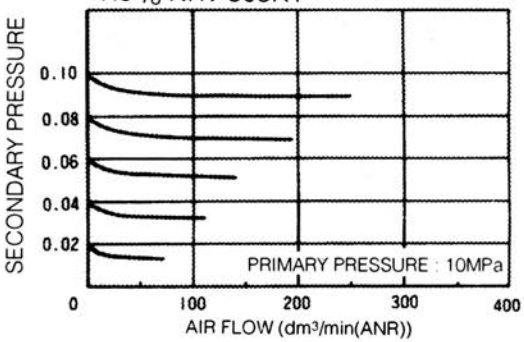

FLOW CHARACTERISTIC CURVE
Rc^{1/2} NRV-304K1

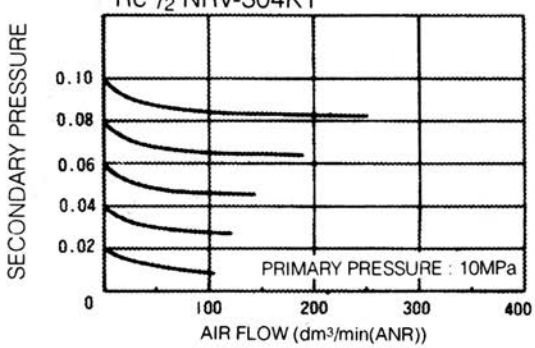

AIR REGULATOR

NRV-400 SERIES (Rc^{1/2}~Rc1)



GAUGE ON OPTION

SPECIFICATIONS

FLUID	Filtered Compressed Air
MAXIMUM INLET PRESSURE*	1.0MPa
AMBIENT TEMPERATURE	5 ~ 60°C
OPERATION	Integral pilot operated type (Internal pilot type)
ADJUSTING PRESSURE RANGE	<ul style="list-style-type: none"> •0.02 ~ 0.7MPa (Std.) •0.01 ~ 0.4MPa •0.01 ~ 0.2MPa •0.1 ~ 1.6MPa*
RELIEF	Relieving and Non-relieving

*Max. inlet pressure is 2.8MPa in case of units of 0.1~1.6MPa range.

BASIC MODEL NOS. & OTHERS

Pipe Size	MODEL NUMBER	Adjusting Pressure Range	Gauge Port	Mass (kg)
Rc ^{1/2}	NRV-404	0.02 ~ 0.7MPa	Rc ^{1/8} (2 places)	1.7
	NRV-404K4	0.01 ~ 0.4MPa		
	NRV-404K2	0.01 ~ 0.2MPa		
Rc ^{3/4}	NRV-406	0.02 ~ 0.7MPa		3.1
	NRV-406K4	0.01 ~ 0.4MPa		
Rc1	NRV-410	0.02 ~ 0.7MPa		3.0
	NRV-410K4	0.01 ~ 0.4MPa		

HOW TO ORDER

NRV - 4

① ② ③ ④ ⑤

AIR REGULATOR NRV-400 SERIES

① Pipe size

04	Rc ^{1/2}
06	Rc ^{3/4}
10	Rc1

② Relief

NIL	Relieving type (Std.)
C	Relieving type with constant bleed
N	Non-relieving type

③ Adjusting Pressure Range

NIL	0.02 ~ 0.7MPa (Std.)
K4	0.01 ~ 0.4MPa
K2	0.01 ~ 0.2MPa
K16	0.1 ~ 1.6MPa

④ Gauge

NIL	without Gauge (Std.)
LT	with Gauge of center back connection

⑤ Bracket

NIL	without Bracket
B	with Bracket

DIMENSIONS -mm-

NRV-404(K4, K2) (Rc 1/2)

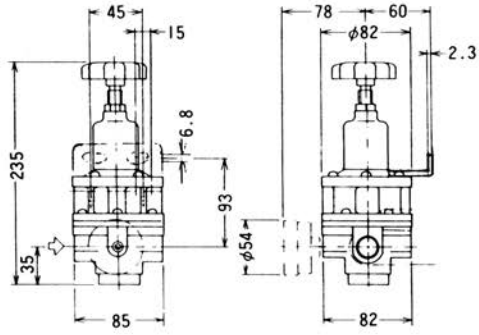

NRV-406, 410(K4, K2) (Rc 3/4, Rc 1)

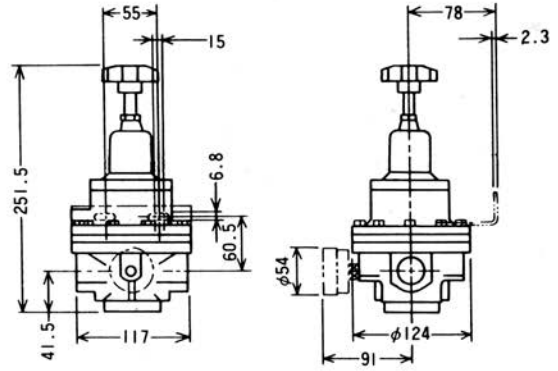

CHARACTERISTIC CURVE

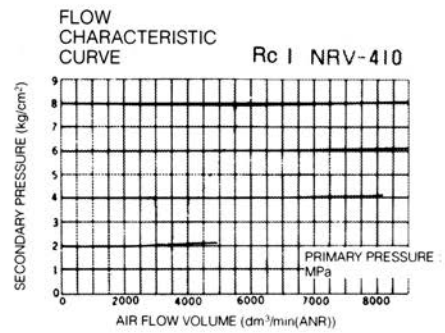
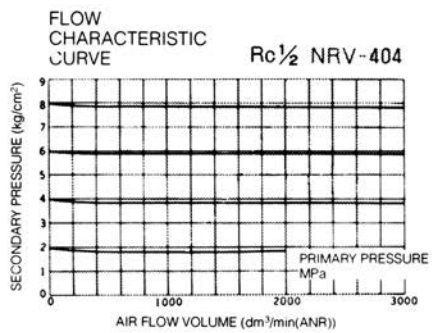
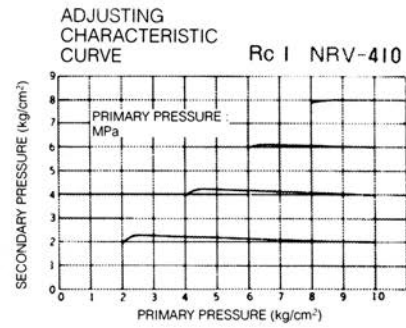
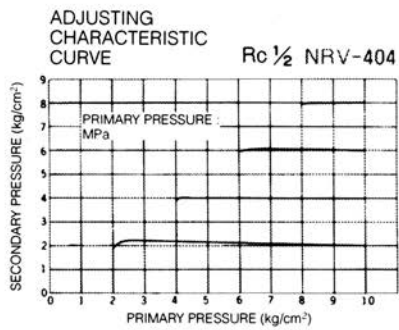

AIR REGULATOR

RVD-400YF SERIES (Rc1¹/₄~Rc2)

INTEGRAL PILOT

SPECIFICATIONS



GAUGE ON OPTION

FLUID	Filtered Compressed Air
MAXIMUM INLET PRESSURE	1.0MPa
AMBIENT TEMPERATURE	5 ~ 60°C
OPERATION	Integral pilot operated type (Internal pilot type)
ADJUSTING PRESSURE RANGE	0.02 ~ 0.8MPa
RELIEF	Relieving and Non-relieving

BASIC MODEL NOS. & OTHERS

Pipe Size	MODEL NUMBER	Gauge Port	Mass (kg)
Rc1 ¹ / ₄	RVD-412YF	Rc ¹ / ₈ (Primary and secondary side have 2 gauge ports each.)	6.3
Rc1 ¹ / ₂	RVD-414YF		
Rc2	RVD-420YF		

HOW TO ORDER

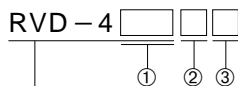

AIR REGULATOR RVD-400F SERIES

① Pipe size

12YF	Rc1 ¹ / ₄ (Flange connection)
14YF	Rc1 ¹ / ₂ (Flange connection)
20YF	Rc2 (Flange connection)

② Relief

NIL	Relieving type (Std.)
N	Non-relieving type

③ Gauge

NIL	without Gauge (Std.)
LT	with Gauge of center back connection at secondary side
HLTT	with Gauges of center back connection at primary and secondary side

DIMENSIONS -mm-

RVD-412~420YF
(Rc1-1/4 ~ Rc2)

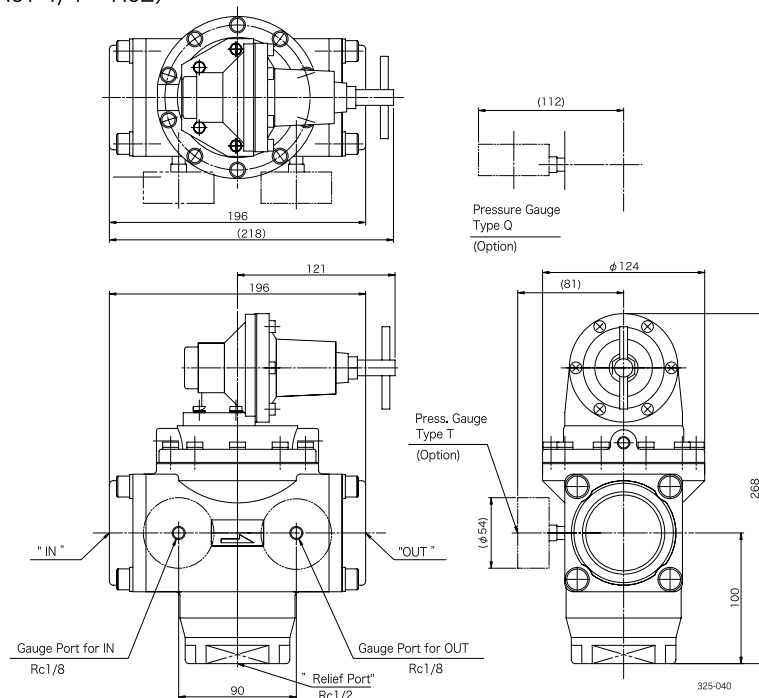

CHARACTERISTIC CURVE

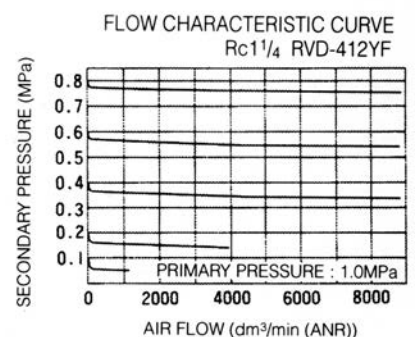
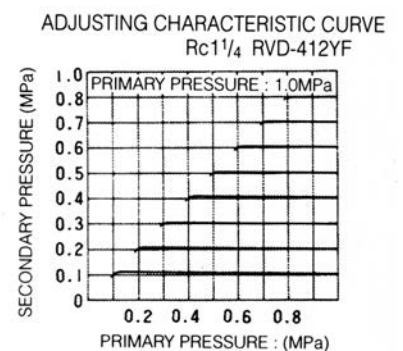

AIR REGULATOR

NRV-500 SERIES (Rc^{1/2} ~ Rc1)

REMO-CON TYPE



GAUGE ON OPTION

SPECIFICATIONS

FLUID	Filtered Compressed Air
MAXIMUM INLET PRESSURE	1.0MPa
AMBIENT TEMPERATURE	5 ~ 60°C
OPERATION	Remote controlled type (External pilot operated type)
OUTLET PRESSURE ADJUSTING RANGE	0.02 ~ 0.8MPa (within the limits of pilot regulator)
RELIEF	Relieving and Non-relieving

BASIC MODEL NOS. & OTHERS

Pipe Size	MODEL NUMBER		Gauge Port	Mass (kg)
	Relieving	Non-relieving		
Rc ^{1/2}	NRV-504	NRV-504N	Rc ^{1/8} (2 sides)	0.85
Rc ^{3/4}	NRV-506	NRV-506N		2.3
Rc1	NRV-510	NRV-510N		2.1

HOW TO ORDER

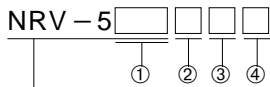

AIR REGULATOR NRV-500 SERIES

① Pipe size

04	Rc ^{1/2}
06	Rc ^{3/4}
10	Rc1

② Relief

NIL	Relieving type (Std.)
N	Non-relieving type
C	Relieving type with constant bleed

③ Gauge

NIL	without Gauge (Std.)
LT	with Gauge of center back connection at secondary side

④ Bracket

NIL	without Bracket (Std.)
B	with Bracket

DIMENSIONS —mm—

NRV-504 (Rc 1/2)

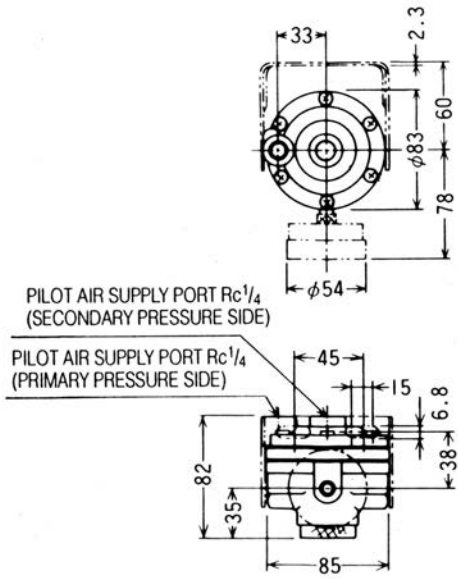

NRV-506, 510 (Rc 3/4, Rc 1)

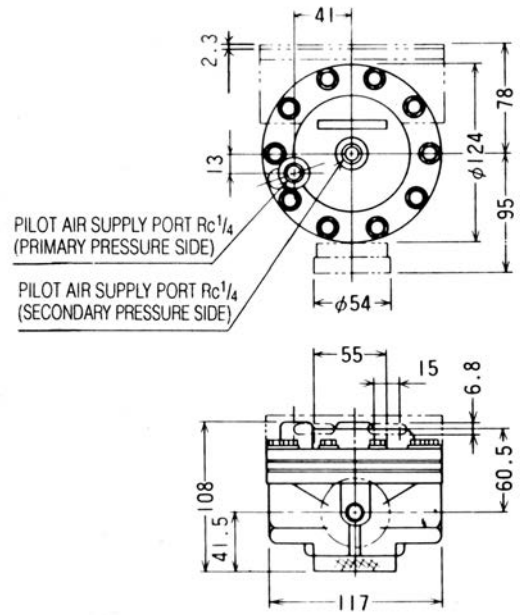

CHARACTERISTIC CURVE

ADJUSTING CHARACTERISTIC CURVE
Rc 1/2 NRV-504

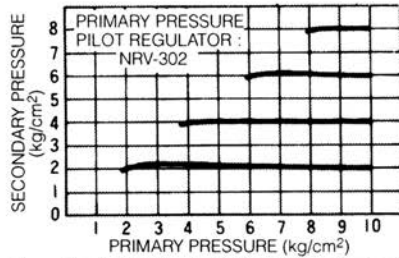

ADJUSTING CHARACTERISTIC CURVE
Rc 1/2 NRV-510

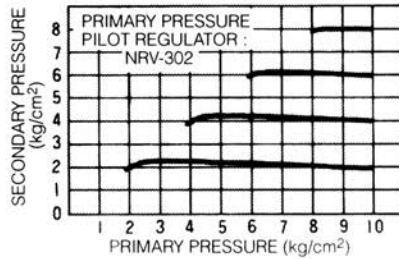

FLOW CHARACTERISTIC CURVE
Rc 1/2 NRV-504

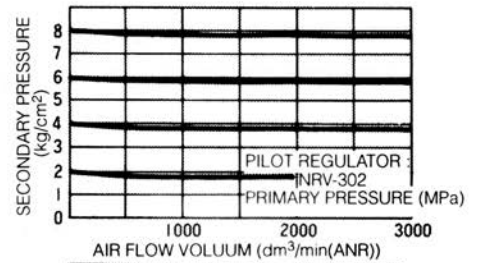

FLOW CHARACTERISTIC CURVE
Rc 1 NRV-510

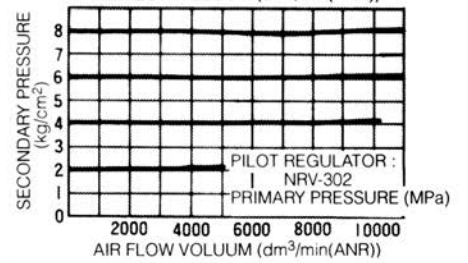

AIR REGULATOR

RVD-500YF SERIES (Rc1 $\frac{1}{4}$ ~Rc2)

REMO-CON TYPE



GAUGE ON OPTION

SPECIFICATIONS

FLUID	Filtered Compressed Air
MAXIMUM INLET PRESSURE	1.0MPa
AMBIENT TEMPERATURE	5 ~ 60°C
OPERATION	Remote controlled type (External pilot type)
ADJUSTING PRESSURE RANGE	0.02 ~ 0.8MPa
RELIEF	Relieving and Non-relieving

BASIC MODEL NOS. & OTHERS

Pipe Size	MODEL NUMBER	Relief Port	Gauge Port	Mass (kg)
Rc1 $\frac{1}{4}$	RVD-512YF	Rc $\frac{1}{2}$	Rc $\frac{1}{8}$ (Primary and secondary side have 2 gauge ports each.)	4.8
Rc1 $\frac{1}{2}$	RVD-514YF			
Rc2	RVD-520YF			4.6

HOW TO ORDER

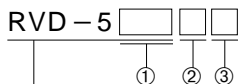

AIR REGULATOR RVD-500F SERIES

① Pipe size

12YF	Rc1 $\frac{1}{4}$ (Flange connection)
14YF	Rc1 $\frac{1}{2}$ (Flange connection)
20YF	Rc2 (Flange connection)

② Relief

NIL	Relieving type (Std.)
N	Non-relieving type

③ Gauge

NIL	without Gauge (Std.)
LT	with Gauge of center back connection at secondary side
HLTT	with Gauges of center back connection at primary and secondary side

DIMENSIONS -mm-

RVD-512F~520YF (Rc1-1/4~2)

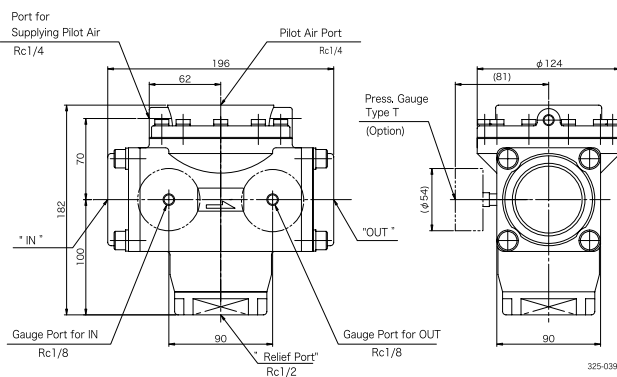

325-039

SELECTION CHART FOR PILOT REGULATOR

PILOT REGULATOR MODEL NO.	MASTER VALVE ADJUSTABLE RANGES (MPa)	PURPOSE
NRV-302	0.02 ~ 0.8	GENERAL PURPOSE
NRV-302K3	0.01 ~ 0.3	
R31-200-0000	0.02 ~ 0.7	
R31-200-C000	0.01 ~ 0.3	
R22-200-0000	0.05 ~ 0.8	
R22-200-3000	0.02 ~ 0.3	PRECISE SET PURPOSE
NRV-802	0.02 ~ 0.7	
NRV-802K4	0.01 ~ 0.4	
NRV-802K2	0.01 ~ 0.2	
R42-201-8000	0.08 ~ 0.8	
R42-201-4000	0.04 ~ 0.4	

REMOTE CONTROL REGULATOR AND PILOT REGULATOR

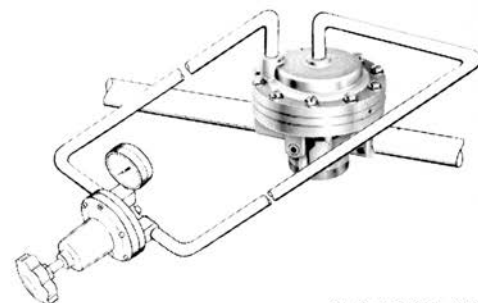

PILOT REGULATOR

CHARACTERISTIC CURVE

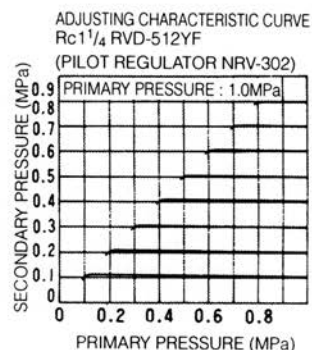
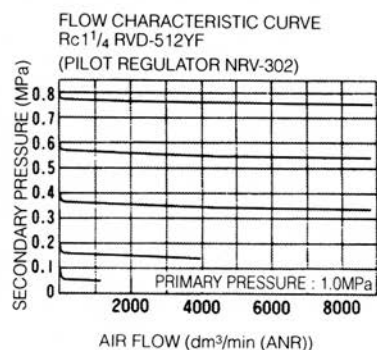

AIR REGULATOR FEED-BACK INTEGRAL TYPE

R50 SERIES (Rc¹/₄~Rc1¹/₄)

HIGH RELIEF TYPE



GAUGE ON OPTION

SPECIFICATIONS

FLUID	Filtered Compressed Air Use air filter with 5µm element.
MAXIMUM INLET PRESSURE	1.0MPa
AMBIENT TEMPERATURE	5 ~ 60°C
OPERATION	Integral Feed-back pilot operated (Internal Pilot type)
ADJUSTING PRESSURE RANGE	0.05 ~ 0.8MPa
RELIEF	High-relieving
STANDARD EQUIPPED PART	Bracket and Adapter for connecting pressure gauge

BASIC MODEL NOS. & OTHERS

Pipe Size	MODEL NUMBER	Pressure Gauge Port	Mass (kg)	Relief Port
Rc ¹ / ₄	R53-201-00B0	Rc ¹ / ₈ only one side (Connect gauge with adapter.)	2.0	Rc ¹ / ₄
Rc ³ / ₈	R53-301-00B0			Rc ³ / ₈
Rc ¹ / ₂	R53-401-00B0			Rc ¹ / ₂
Rc ¹ / ₂	R58-403-00B0		2.4	Rc ¹ / ₂
Rc ³ / ₄	R58-603-00B0			Rc ³ / ₄
Rc1	R58-803-00B0			Rc1
Rc1 ¹ / ₄	R58-A03-00B0			Rc1 ¹ / ₄

HOW TO ORDER

R58-80※-00B0

③ ④ ⑦ ⑨ ⑩

⑥ Design revise no.

AIR REGULATOR R50 SERIES

③ Basic Body Size

3 | ³/₈B
8 | 1B

④ Pipe Size

2 | Rc¹/₄
3 | Rc³/₈
4 | Rc¹/₂
6 | Rc³/₄
8 | Rc1
A | Rc1¹/₄

*Pipe size should be selected from pipe sizes in a range according to the basic body size.
Refer to the list of BASIC MODEL NOS.

⑦ Operation & Adjusting Pressure Range

0 | Integral pilot operated
(Internal pilot type)
0.05 ~ 0.8MPa

⑨ Bracket

B | with Bracket

⑩ Pressure Gauge

0 | without gauge
1 | with gauge
(φ50 1MPa
Rc¹/₈ center back connection)

DIMENSIONS -mm- R50-O SERIES (FEED-BACK INTEGRAL TYPE)

R53-201-00B0
 R53-301-00B0
 R53-401-00B0

MODEL NO.	A	MODEL NO. OF MUFFLER
R53-201-00B *	(72)	SL-02
R53-301-00B *	(77)	SL-03
R53-401-00B *	(120)	

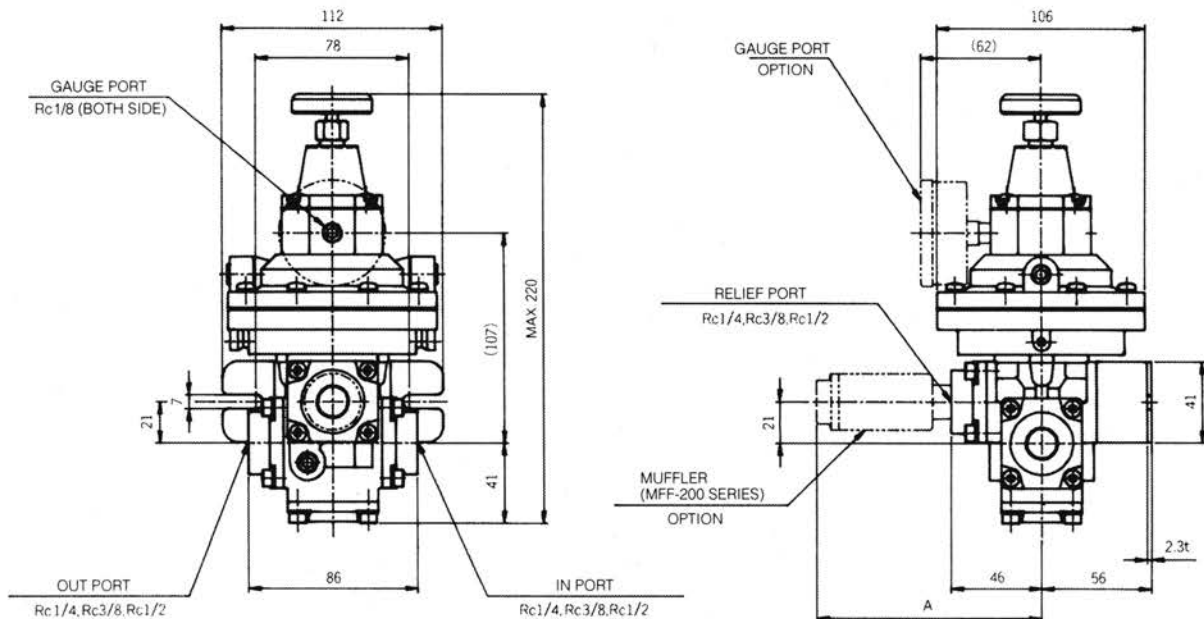
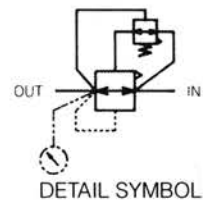

R58-403-00B0
 R58-603-00B0
 R58-803-00B0
 R58-A03-00B0

MODEL NO.	A	MODEL NO. OF MUFFLER
R58-403-00B *	(132)	MFF-204
R58-603-00B *	(128)	MFF-306A
R58-803-00B *	(192)	MFF-310
R58-A03-00B *	(242)	MFF-312+FNJ1032

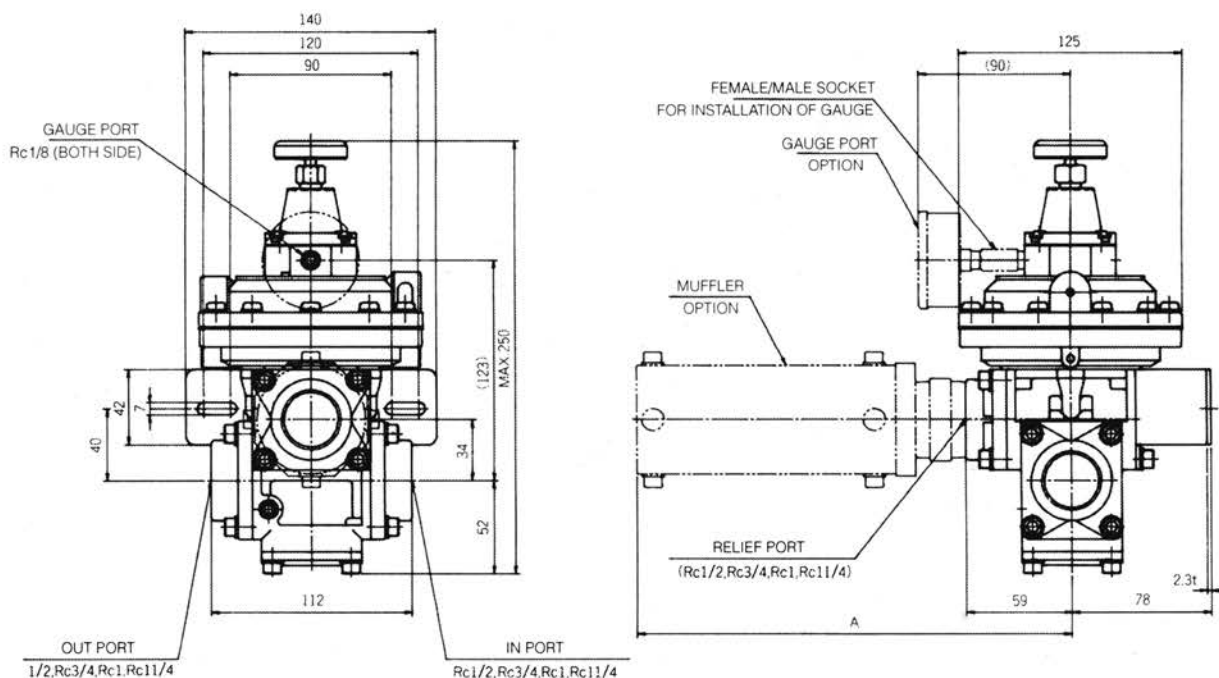
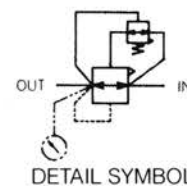

AIR REGULATOR FEED-BACK REMOTE CONTROL TYPE R50-R SERIES (Rc¹/₂~Rc¹/₄)

PILOT OPERATED FEED-BACK TYPE

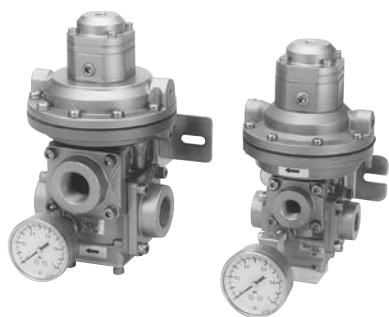

GAUGE ON OPTION

SPECIFICATIONS

FLUID	Filtered Compressed Air
MAXIMUM INLET PRESSURE	1.0MPa
AMBIENT TEMPERATURE	5 ~ 60°C
OPERATION	Feed-Back Pilot Remote control type (External Pilot operated type)
ADJUSTING PRESSURE RANGE	0.05 ~ 0.8MPa Depends on adjusting pressure range of pilot regulator.
RELIEF	High-relieving
EQUIPPED PART WITH STANDARD MODEL	Bracket and Adapter for connecting pressure gauge

BASIC MODEL NOS. & OTHERS

Pipe Size	MODEL NUMBER	External Pilot Port	Gauge Port (Feed-back pressure Port)	Mass (kg)	Relief Port	
Rc ¹ / ₄	R53-201-R0B0	Rc ¹ / ₈ (With Rc ¹ / ₈ pressure supply port for pilot regulator.)	Rc ¹ / ₈ (Only one side. Connect gauge with adapter.)	1.6	Rc ¹ / ₄	
Rc ³ / ₈	R53-301-R0B0				Rc ³ / ₈	
Rc ¹ / ₂	R53-401-R0B0				Rc ¹ / ₂	
Rc ¹ / ₂	R58-403-R0B0			2.6		Rc ¹ / ₂
Rc ³ / ₄	R58-603-R0B0					Rc ³ / ₄
Rc1	R58-803-R0B0					Rc1
Rc ¹ / ₄	R58-A03-R0B0					Rc ¹ / ₄

HOW TO ORDER

R58-80※-R0B0

③ ④ ⑦ ⑨ ⑩

Design revise no.

AIR REGULATOR R50 SERIES

③ Basic Body Size

3 | 3/8B
8 | 1B
B | 1 1/2B

④ Pipe Size

2 | Rc¹/₄
3 | Rc³/₈
4 | Rc¹/₂
6 | Rc³/₄
8 | Rc1
A | Rc¹/₄

*Pipe size should be selected from pipe sizes in a range according to the basic body size.
Refer to the list of BASIC MODEL NOS.

⑦ Operation & Adjusting Pressure Range

R | Feed-Back Pilot remote control type (External pilot operated type)
0.05 ~ 0.8MPa

⑨ Bracket

B | with Bracket

⑩ Pressure Gauge

0 | without gauge
1 | with gauge (ø50 1.0MPa Rc¹/₈ center back gauge)

**When remote control type regulator is operated by feed-back pilot pressure control, pressure gauge port should be prepared by the user.

DIMENSIONS

-mm- R50-R SERIES (FEED-BACK INTEGRAL TYPE)

R53-201-R0B0
 R53-301-R0B0
 R53-401-R0B0

MODEL NO.	A	MODEL NO. OF MUFFLER
R53-201-R0B *	(72)	SL-02
R53-301-R0B *	(77)	SL-03
R53-401-R0B *	(120)	MFF-204

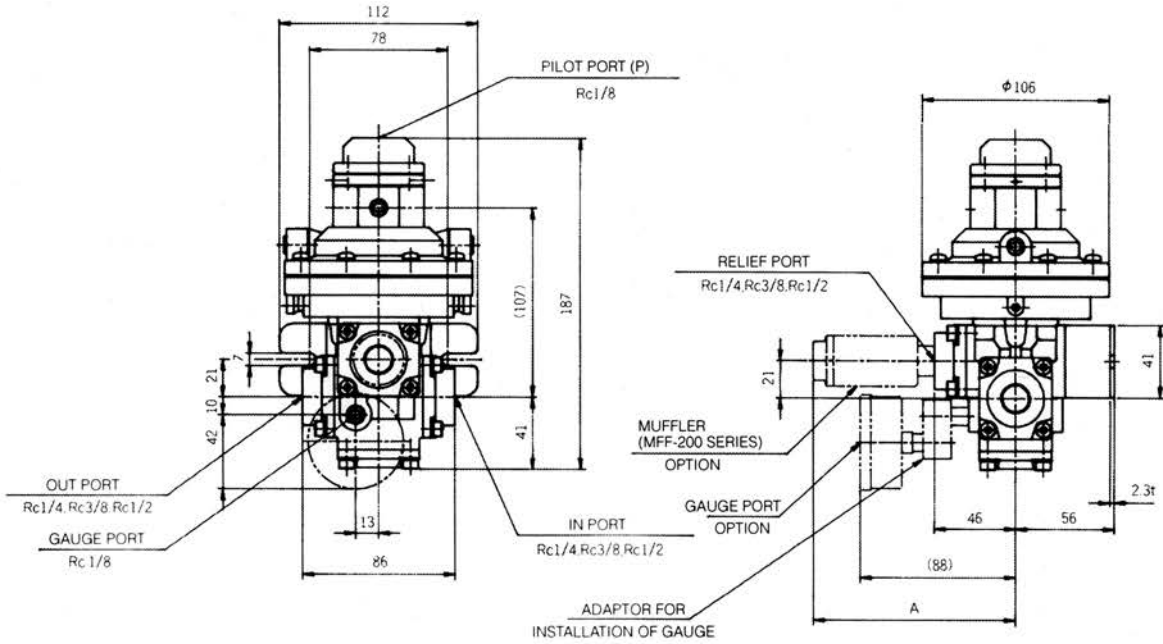
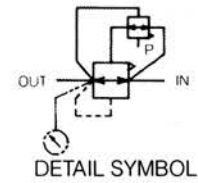

R58-403-R0B0
 R58-603-R0B0
 R58-803-R0B0
 R58-A03-R0B0

MODEL NO.	A	MODEL NO. OF MUFFLER
R58-403-R0B *	(132)	MFF-204
R58-603-R0B *	(128)	MFF-306A
R58-803-R0B *	(192)	MFF-310
R58-A03-R0B *	(242)	MFF-312 + FNJ1032

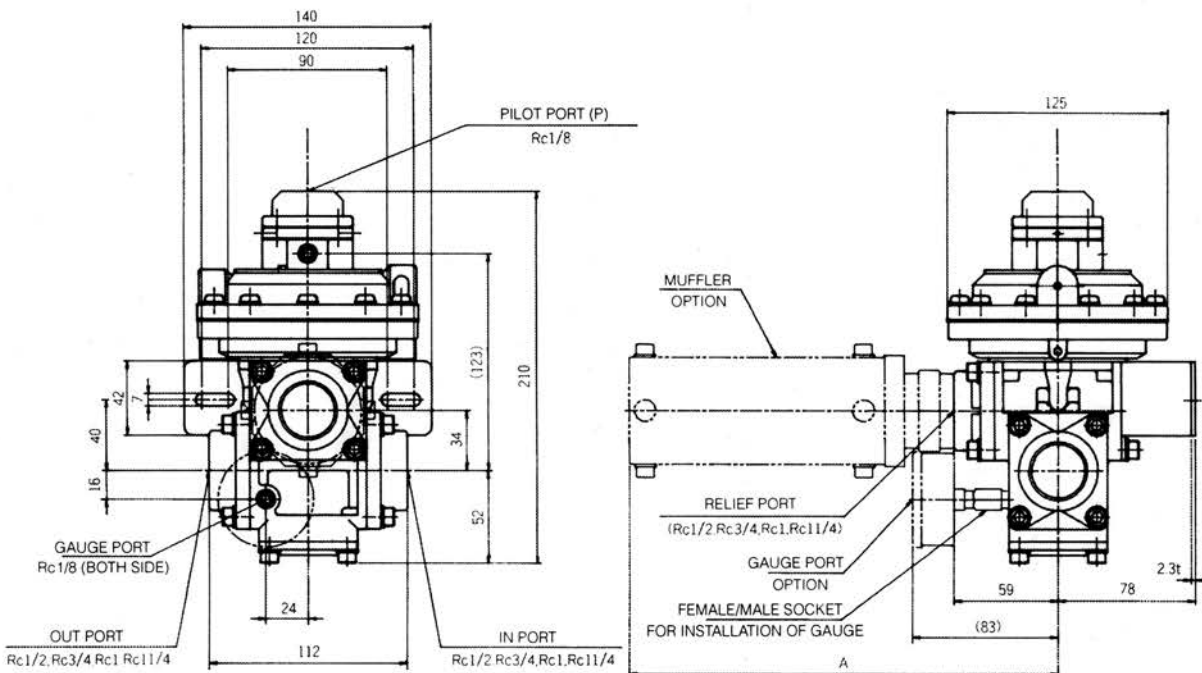
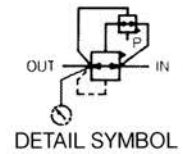

AIR REGULATOR REMOTE CONTROL TYPE R50-M SERIES (Rc¹/₂~Rc2)

PILOT OPERATED HIGH RELIEF TYPE

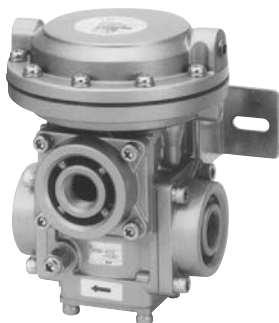

SPECIFICATIONS

FLUID	Filtered Compressed Air
MAXIMUM INLET PRESSURE	1.0MPa
AMBIENT TEMPERATURE	5 ~ 60°C
OPERATION	Remote controlled type (External Pilot operated type)
ADJUSTING PRESSURE RANGE	0.05 ~ 0.8MPa Depends on adjusting pressure range of pilot regulator.
RELIEF	High-relieving
EQUIPPED PART WITH STANDARD MODEL	Bracket and Adapter for connecting pressure gauge

BASIC MODEL NOS. & OTHERS

Pipe Size	MODEL NUMBER	External Pilot Port	Gauge Port (Feed-back pressure Port)	Mass (kg)	Relief Port
Rc ¹ / ₄	R53-201-M0B0	Rc ¹ / ₈ (With Rc ¹ / ₈ pressure supply port for pilot regulator)	Rc ¹ / ₈ (Only one side. Connect gauge with adapter.)	1.3	Rc ¹ / ₄
Rc ³ / ₈	R53-301-M0B0				Rc ³ / ₈
Rc ¹ / ₂	R53-401-M0B0				Rc ¹ / ₂
Rc ¹ / ₂	R58-403-M0B0			2.0	Rc ¹ / ₂
Rc ³ / ₄	R58-603-M0B0				Rc ³ / ₄
Rc1	R58-803-M0B0				Rc1
Rc1 ¹ / ₄	R58-A03-M0B0				Rc1 ¹ / ₄
Rc1 ¹ / ₄	R5B-A00-M0B0			7.0	Rc1 ¹ / ₄
Rc1 ¹ / ₂	R5B-B00-M0B0				Rc1 ¹ / ₂
Rc2	R5B-C00-M0B0				Rc2

HOW TO ORDER

R58-80※-M0B0

③ ④ ⑦ ⑨ ⑩

Design revise no.

AIR REGULATOR R50 SERIES

③ Basic Body Size

3 | ³/₈B
8 | 1B
B | 1¹/₂B

④ Pipe Size

2 | Rc¹/₄
3 | Rc³/₈
4 | Rc¹/₂
6 | Rc³/₄
8 | Rc1
A | Rc1¹/₄
B | Rc1¹/₂
C | Rc2

*Pipe size should be selected from pipe sizes in a range according to the basic body size.
Refer to the list of BASIC MODEL NOS.

⑦ Operation & Adjusting Pressure Range

M | Remote controlled type (External pilot operated type)
(Adjusting pressure range is limited by the pressure range of pilot regulator)

⑨ Bracket

B | with Bracket

⑩ Pressure Gauge

0 | without gauge
1 | with gauge (ø50 1.0MPa Rc¹/₈ center back gauge)

**When remote control type regulator is operated by feed-back pilot pressure control, pressure gauge port should be prepared by the user.

DIMENSIONS

-mm- R50-M SERIES (FEED-BACK INTEGRAL TYPE)

R53-201-M0B0
R53-301-M0B0
R53-401-M0B0

MODEL NO.	A	MODEL NO. OF MUFFLER
R53-201-R0B *	(72)	SL-02
R53-301-R0B *	(77)	SL-03
R53-401-R0B *	(120)	MFF-204

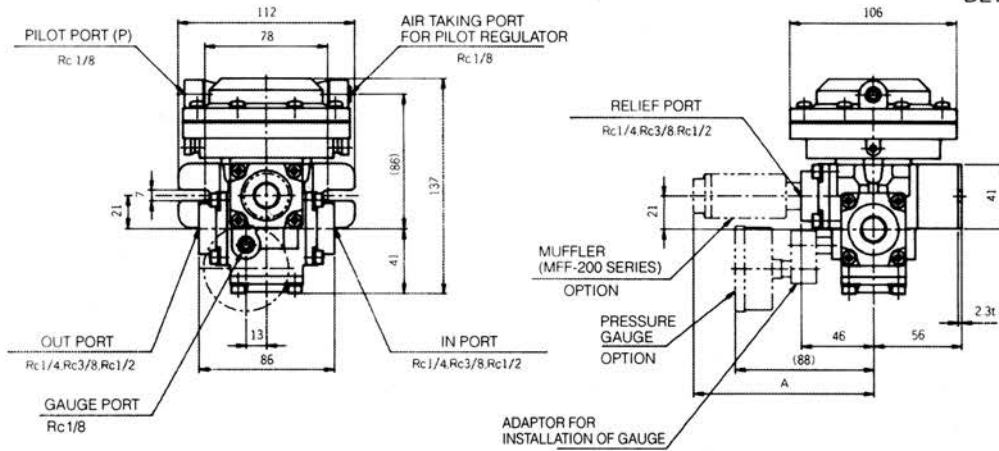
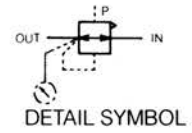

NOTE. WHEN USING FEED-BACK PRESSURE CONTROL, CONNECT FEED-BACK LINE TO GAUGE PORT.

R58-403-M0B0
R58-603-M0B0
R58-803-M0B0
R58-A03-M0B0

MODEL NO.	A	MODEL NO. OF MUFFLER
R58-403-M0B *	(132)	MFF-204
R58-603-M0B *	(128)	MFF-306A
R58-803-M0B *	(192)	MFF-310
R58-A03-M0B *	(242)	MFF-312 + FNJ1032

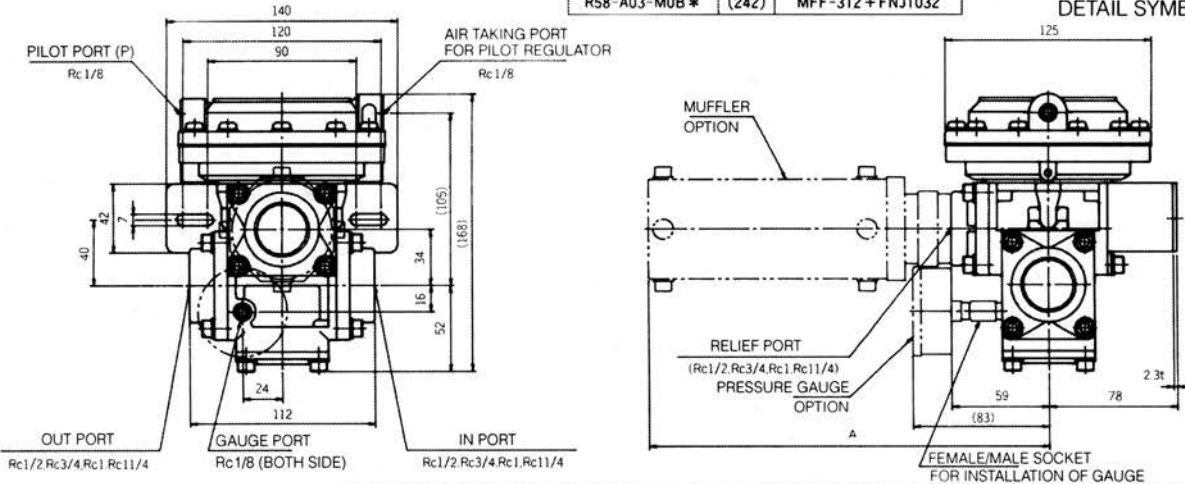
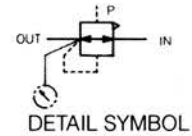

NOTE. WHEN USING FEED-BACK PRESSURE CONTROL, CONNECT FEED-BACK LINE TO GAUGE PORT.

R5B-A00-M0B0
R5B-B00-M0B0
R5B-C00-M0B0

MODEL NO.	X	L1	L2
R5B-A00-M0B0	1 1/4	140	146
R5B-B00-M0B0	1 1/2	140	146
R5B-C00-M0B0	2	146	149

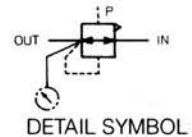
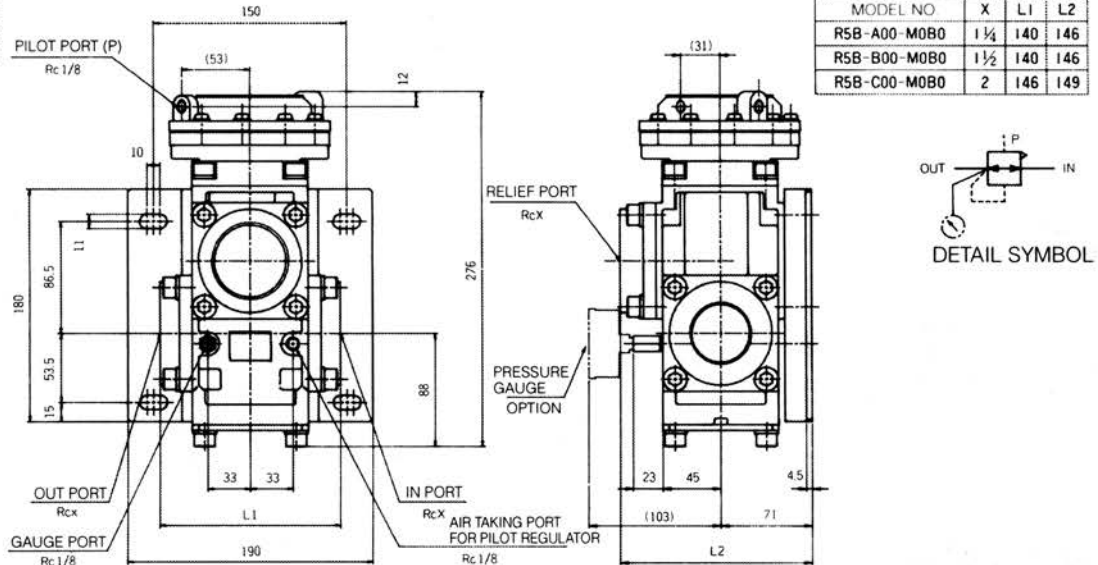

AIR REGULATOR

NRV-802 SERIES (Rc¹/₄)

PRECISION TYPE

SPECIFICATIONS



MODEL NUMBER	NRV-802	NRV-802K16	NRV-802K4	NRV-802K2
PIPE SIZE	Rc ¹ / ₄			
FLUID	Filtered Clean Air (Use 25µm filter element)			
MAXIMUM INLET PRESSURE*	1.0MPa			
AMBIENT TEMPERATURE	5 ~ 60°C			
ADJUSTING PRESSURE RANGE	0.02 ~ 0.7MPa	0.1 ~ 1.6MPa	0.01 ~ 0.4MPa	0.01 ~ 0.2MPa
OPERATION	Directly operated and constant bleed type			
RELIEF	Relieving type			
GAUGE PORT	Rc ¹ / ₈			
MASS (kg)	0.84			

*Max. inlet pressure is 2.8MPa in case of 0.1~1.6MPa range (K16).

HOW TO ORDER

NRV - 802

① ② ③ ④

Pipe Size: Rc¹/₄

PRECISION REGULATOR NRV-802 SERIES

① Mounting

NIL (Std.)
P Panel mount type

② Adjusting pressure range

NIL 0.02 ~ 0.7MPa
K16 0.1 ~ 1.6MPa
K4 0.01 ~ 0.4MPa
K2 0.01 ~ 0.2MPa

③ Pressure Gauge

NIL without Gauge (Std.)
LT with Gauge of center back connection
LQ with Gauge of bottom connection

④ Bracket

NIL without Bracket (Std.)
B with Bracket

DIMENSIONS -mm-

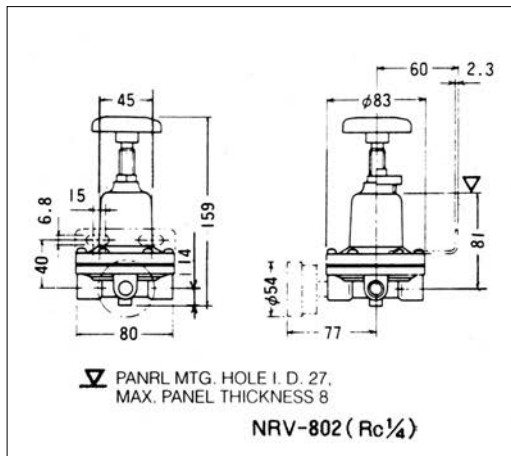

CHARACTERISTIC CURVE

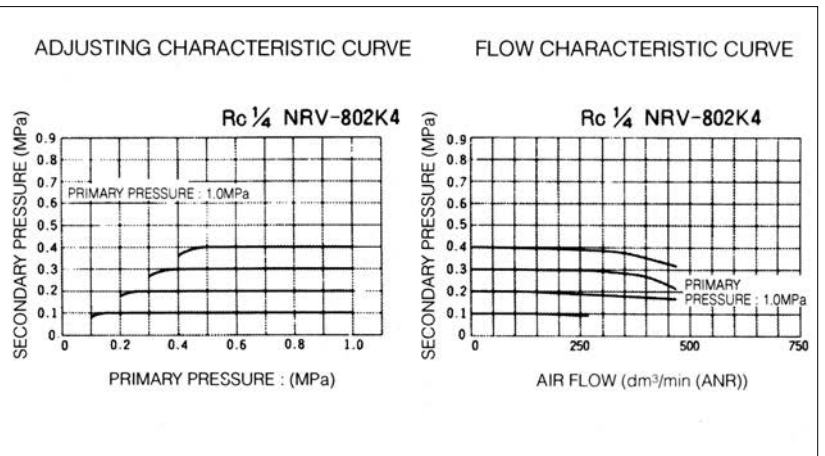

PILOT REGULATOR for FEED-BACK CONTROL

NRV-802D (Rc¹/₄)



GAUGE ON OPTION

SPECIFICATIONS & MODEL NUMBERS

MODEL NUMBER	NRV-802D
PIPE SIZE	Rc ¹ / ₄ (IN, OUT Port)
FLUID	Filtered Clean Air (w/5µm element)
MAXIMUM INLET PRESSURE	1.0MPa
AMBIENT TEMPERATURE	5 ~ 60°C
FEED BACK PORT	Rc ¹ / ₈
MASS (kg)	0.95

* For panel mount, add "P" at the end of model no.

Note: This regulator is used only as pilot regulator. In this case, master regulator recommended is R50-M series high relieving type.

PIPING

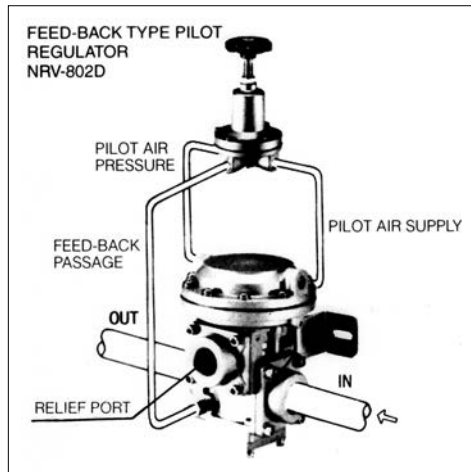

DIMENSIONS -mm-

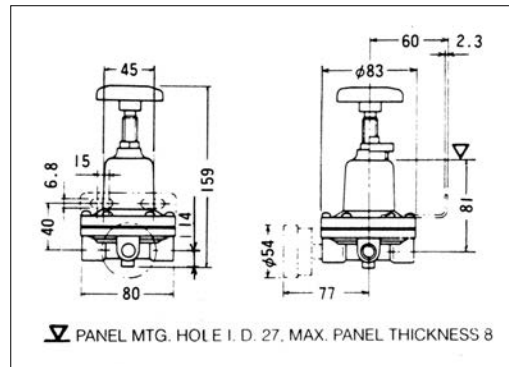

Length of pilot air piping should be less than 1m.

FEED-BACK PILOT REGULATOR

NRV-502JD (Rc¹/₄)



SPECIFICATIONS & MODEL NUMBERS

MODEL NUMBER	NRV-502JD
PIPE SIZE	Rc ¹ / ₄ (IN, OUT Port) Rc ¹ / ₄ Pilot Air Port
FLUID	Filtered Clean Air (w/5µm element)
MAXIMUM INLET PRESSURE	1.0MPa
AMBIENT TEMPERATURE	5 ~ 60°C
FEED BACK PORT	Rc ¹ / ₈
MASS (kg)	0.95

PIPING

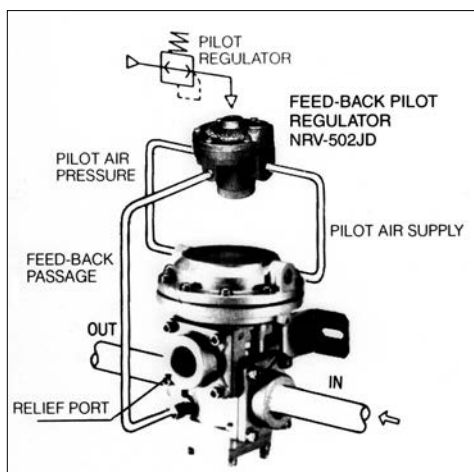

DIMENSIONS -mm-

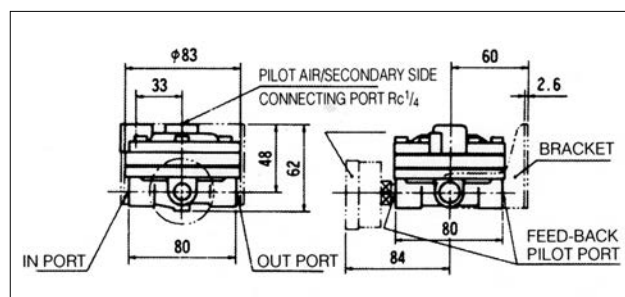

Length of pilot air piping is possible to be long by using remotely controlled NRV-502JD.

AIR REGULATOR

R42 SERIES (Rc^{1/4})

PRECISION TYPE



GAUGE ON OPTION

SPECIFICATIONS

FLUID	Filtered Dry Clean Air (Use oil removal filter in supply line)
MAXIMUM INLET PRESSURE	1.0MPa
AMBIENT TEMPERATURE	0 ~ 70°C
ADJUSTING PRESSURE RANGE	<ul style="list-style-type: none"> •0.04 ~ 0.4MPa •0.08 ~ 0.8MPa •0.02 ~ 0.2MPa
OPERATION	Integral feed-back controlled constant bleed type (Constant bleed flow: max. 1.7dm ³ /min. (ANR) at inlet pressure: 0.17MPa outlet pressure: 0
RELIEF	Relieving type
MASS	0.35kg

BASIC MODEL NOS. & OTHERS

Pipe Size	MODEL NUMBER	Adjusting Pressure Range	Gauge Port
Rc ^{1/4}	R42-201-4000	0.04 ~ 0.4MPa	Rc ^{1/8}
	R42-201-8000	0.08 ~ 0.8MPa	
	R42-201-2000	0.02 ~ 0.2MPa	

HOW TO ORDER

R 4 2 - 2 0 1 - 4 0 0 0

③ ④ ⑦ ⑧ ⑨ ⑩

PRECISION REGULATOR R42 SERIES

③ Basic Body Size

2 | 1/4B

④ Pipe Size

2 | Rc^{1/4}

⑦ Adjusting pressure range

4 | 0.04 ~ 0.4MPa

8 | 0.08 ~ 0.8MPa

2 | 0.02 ~ 0.2MPa

⑧ Relief

0 | Relieving type, constant bleed

⑨ Adjusting Handle

0 | Hand wheel
(panel mount)
T | Tamper proof

⑩ Pressure Gauge

0 | without Gauge (Std.)

1 | with Gauge of center back connection

DIMENSIONS

—mm—

325-038

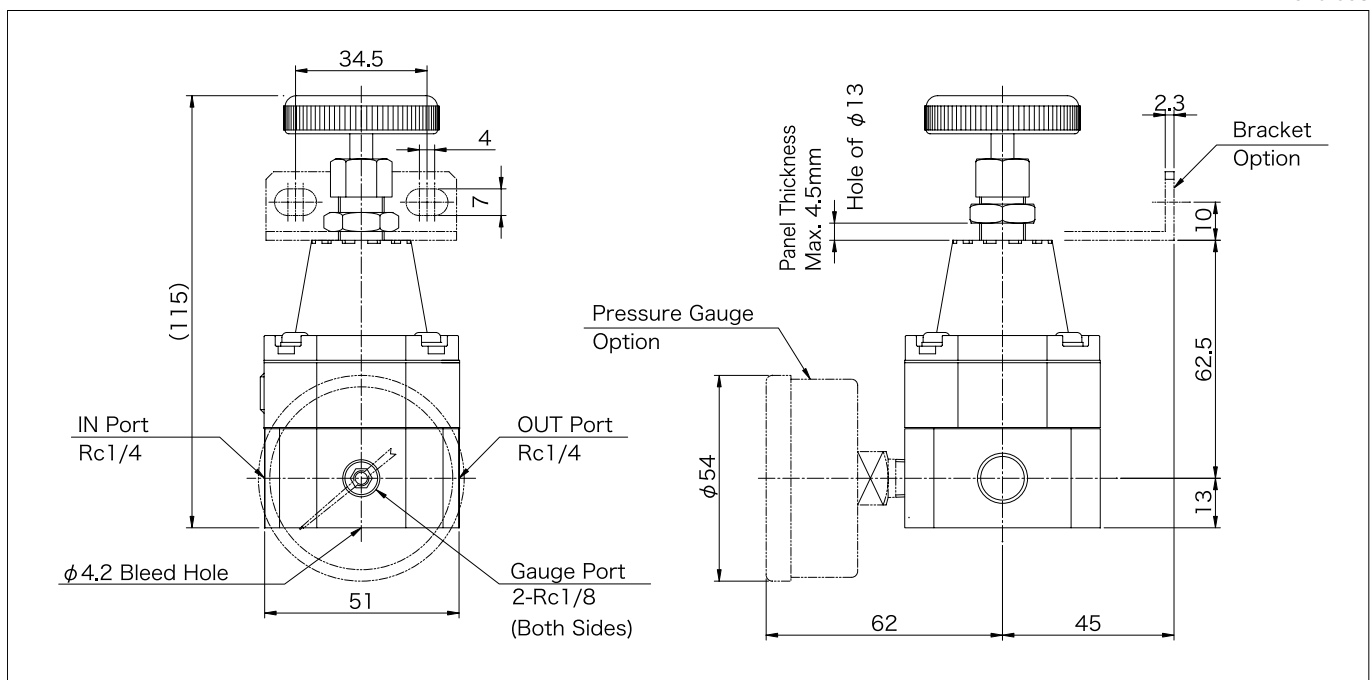

(By Dwg 3J-2123, -xxxx)

CAM CONTROL REGULATOR

NRV-300A SERIES (Rc^{1/4}~Rc^{1/2})



GAUGE ON OPTION

SPECIFICATIONS & MODEL NOS.

MODEL NUMBER	NRV-302A	NRV-303A	NRV-304A
PIPE SIZE	Rc ^{1/4}	Rc ^{3/8}	Rc ^{1/2}
FLUID	Filtered Compressed Air		
MAXIMUM INLET PRESSURE	1.0MPa		
ADJUSTING PRESSURE RANGE	0.02 ~ 0.5MPa		
STROKE	0 ~ 20mm		
FORCE FOR OPERATION OF ADJUSTING ROD	Max. 1100N		
AMBIENT TEMPERATURE	5 ~ 60°C		
OPERATION	Directly spring operated type		
RELIEF	Relieving		
MASS (kg)	1.7		

HOW TO ORDER

NRV - 30 A

①
②
③
Operation:
Cam Controlled

AIR REGULATOR NRV-300A SERIES

① Pipe size

2	Rc ^{1/4}
3	Rc ^{3/8}
4	Rc ^{1/2}

③ Pressure Gauge

NIL	without Gauge (Std.)
LT	with Gauge of center back connection

② Adjusting Pressure Range & Stroke (= travel of adjusting rod)

Mark	Adjusting Pressure Range	Stroke (mm)	Thrust Force for Adjustment
NIL (Std.)	0.02 ~ 0.5MPa	20	~ 110kgf
3.5 - 20	0.01 ~ 0.35MPa	20	~ 77kgf
3 - 20	0.01 ~ 0.3MPa	20	~ 66kgf
2 - 20	0.01 ~ 0.2MPa	20	~ 44kgf
1 - 20	0.01 ~ 0.1MPa	20	~ 22kgf
1 - 8	0.01 ~ 0.1MPa	8	~ 22kgf

DIMENSIONS -mm-

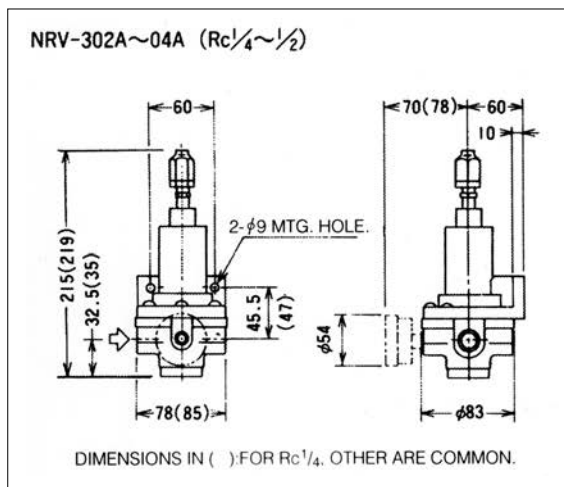

STROK VS. PRESSURE CHARACTERISTIC CURVE SAMPLE

NRV-302A
(STANDARD)

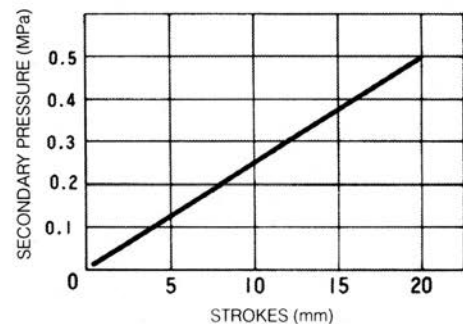

WATER REGULATOR

R31 SERIES (Rc¹/₈, Rc¹/₄)

RL4 SERIES (Rc¹/₄~Rc¹/₂)

NRV-1200 (Rc³/₄~Rc1)



R31
(GAUGE ON OPTION)



RL4
(GAUGE ON OPTION)

SPECIFICATIONS

FLUID	Water or Non-corrosive and low viscosity liquids
MAXIMUM INLET PRESSURE	1.0MPa
AMBIENT TEMPERATURE	5 ~ 60°C
OPERATION	Directly spring operated type
RELIEF	Non-relieving

BASIC MODEL NOS. & OTHERS

Series	Pipe Size	MODEL NUMBER	Adjusting Pressure Range MPa	Gauge Port	Mass (kg)
R31	Rc ¹ / ₈	R31-100-0100-30	0.02 ~ 0.7	Rc ¹ / ₈ (2 places)	0.1
		R31-100-C100-30	0.01 ~ 0.35		
		R31-100-B100-30	0.01 ~ 0.07		
	Rc ¹ / ₄	R31-200-0100-30	0.02 ~ 0.7		
		R31-200-C100-30	0.01 ~ 0.35		
		R31-200-B100-30	0.01 ~ 0.07		
RL4	Rc ¹ / ₄	RL4-201-0100	0.02 ~ 0.8	Rc ¹ / ₄ (2 places)	2.2
		RL4-201-4100	0.01 ~ 0.4		
	Rc ³ / ₈	RL4-301-0100	0.02 ~ 0.8		
		RL4-301-4100	0.01 ~ 0.4		
	Rc ¹ / ₂	RL4-401-0100	0.02 ~ 0.8		
		RL4-401-4100	0.01 ~ 0.4		
NRV-1200	Rc ³ / ₄	NRV-1206	0.02 ~ 0.8	Rc ¹ / ₈ (2 places)	4.7
		NRV-1206K3	0.01 ~ 0.3		
	Rc1	NRV-1210	0.02 ~ 0.8		
		NRV-1210K3	0.01 ~ 0.3		

HOW TO ORDER

R 31 - 200 - 0100 - 30

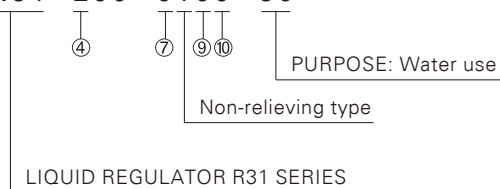

④ Pipe size

- 1 Rc¹/₈
- 2 Rc¹/₄

⑦ Adjusting Pressure Range

- 0 0.02 ~ 0.7MPa
- B 0.01 ~ 0.07MPa
- C 0.01 ~ 0.35MPa

⑨ Accessory

- 0 No Accessory (Std.)
- B Bracket (with Plastic panel nut)
- R Panel nut (Aluminium)
- 2 Panel nut (Plastic)

⑩ Pressure Gauge

- 0 without Gauge (Std.)
- 1 with Gauge of center back connection

RL 4 - 401 - 0100

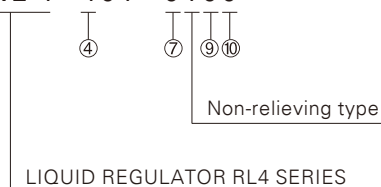

④ Pipe Size

- 2 Rc¹/₄
- 3 Rc³/₈
- 4 Rc¹/₂

⑦ Adjusting Pressure Range

- 0 0.02 ~ 0.8MPa
- 4 0.01 ~ 0.4MPa

⑨ Accessory

- 0 No Accessory (Std.)
- B Bracket
- R Panel nut

⑩ Pressure Gauge

- 0 without Gauge (Std.)
- 1 with Gauge of center back connection
- 2 with Gauge of bottom connection

NRV - 12



④ Pipe Size

- 06 Rc³/₄
- 10 Rc1

⑥ Adjusting pressure range

- NIL 0.02 ~ 0.8MPa
- K4 0.01 ~ 0.3MPa

⑦ Pressure Gauge

- NIL without Gauge (Std.)
- LT with Gauge of center back connection

⑧ Bracket

- NIL without Bracket (Std.)
- B with Bracket

SPECIFICATIONS & MODEL NUMBERS

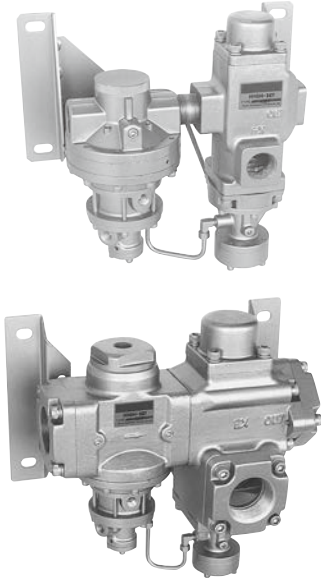

MODEL NUMBER	HS-404Y2	HS-412Y2	HS-414Y2	HS-420Y2
PIPE SIZE	Rc ¹ / ₂	Rc ¹ / ₄	Rc ¹ / ₂	Rc2
EXHAUST PORT CONNECTION	Pipe connection is not available	Rc ¹ / ₂		Rc2
LEAD PORT · PILOT PORT	Rc ¹ / ₄			
FLUID	Filtered Compressed Air			
MAXIMUM INLET PRESSURE	1.0MPa			
AMBIENT TEMPERATURE	5 ~ 60°C			
ADJUSTING PRESSURE RANGE	0.1 ~ 0.8MPa			
ALLOWABLE BACK PRESSURE	1.0MPa			
CONSTANT FOR CHARGING TIME	1250	100		
MASS (kg)	3.5	13		

*Dimension of constant for charging time: $\left[\frac{\text{sec}}{\text{m}^3 \cdot \text{MPa}} \right]$

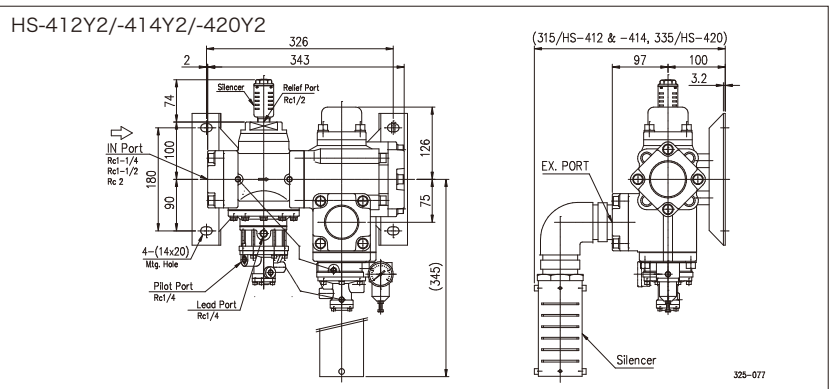
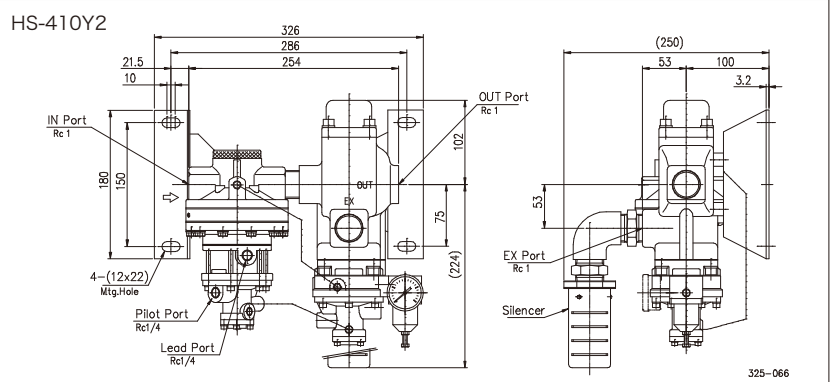
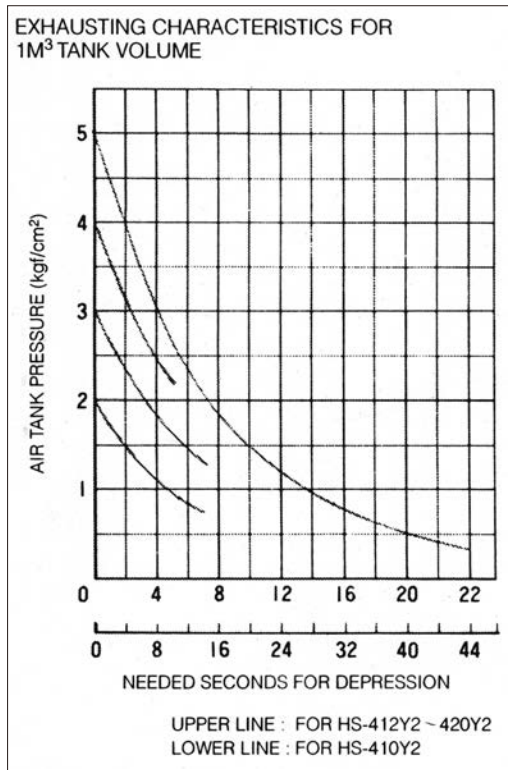
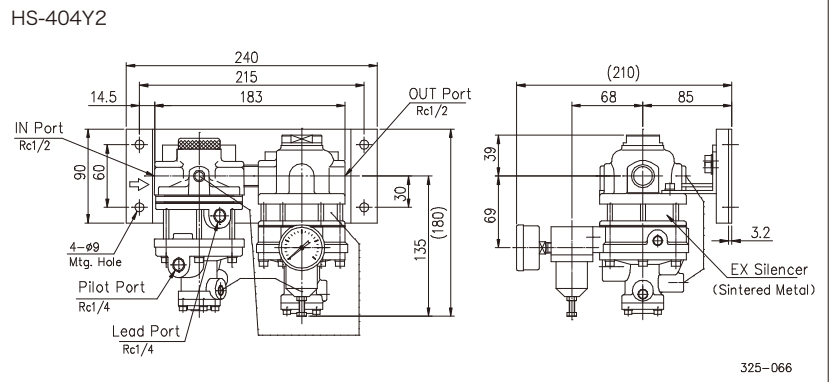
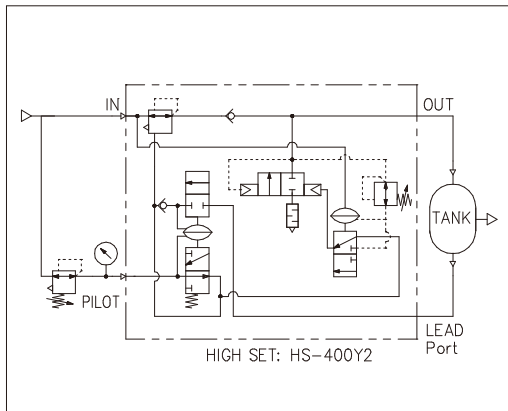

PILOT PRESSURE SELECTING UNIT for High Set HS-400Y2 Series

HSP-302 SERIES (Rc¹/₄)

SPECIFICATIONS

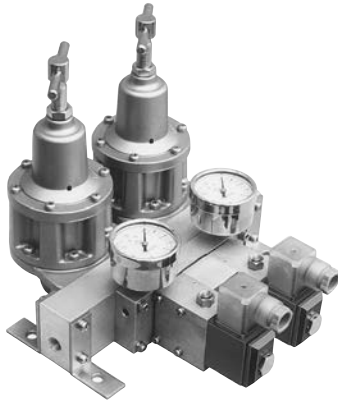

GAUGE ON OPTION

FLUID		Filtered Compressed Air	
MAXIMUM INLET PRESSURE		1.0MPa	
AMBIENT TEMPERATURE		5 ~ 50°C	
AIR REGULATOR	Relief	High sensitive relieving type	
	Adjusting Pressure Range	0.2 ~ 0.7MPa	
SOLENOID VALVE	Operation	3 Way Double Solenoid Pilot operated type	
	Rated Voltage	<ul style="list-style-type: none"> • AC-100V/50, 60Hz, 110V 60Hz • AC-200V/50, 60Hz, 220V 60Hz 	
	Electric Current	AC-100V, 50Hz	AC-200V, 50Hz
	Inrush Current	0.165A	0.08A
	Holding Current	0.102A	0.049A

HOW TO ORDER

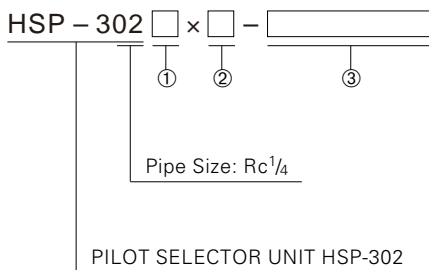

- ① Pilot Lamp for Solenoid Valve
- | | |
|-----|---|
| NIL | DIN connection without pilot lamp (Std.) |
| S | DIN connection with pilot lamp & Surge suppressor |
- ② Nos. of Unit fitted on manifold block
- 1~3

- ③ Pressure Adjustment Handle
- | | |
|-----|----------|
| NIL | T handle |
|-----|----------|
- * Specify required regulator handle by letter in the following table. The arrangement of units to be stacked corresponds to that of letters order from right to left side viewing the pilot pressure selecting unit from the following direction.
Pressure gauge is directed towards this side and solenoid valve upward.

Letter	Rated Voltage
T	T handle
1	Wheel handle (Silver)
2	Wheel handle (Black)
4	Wheel handle (Green)

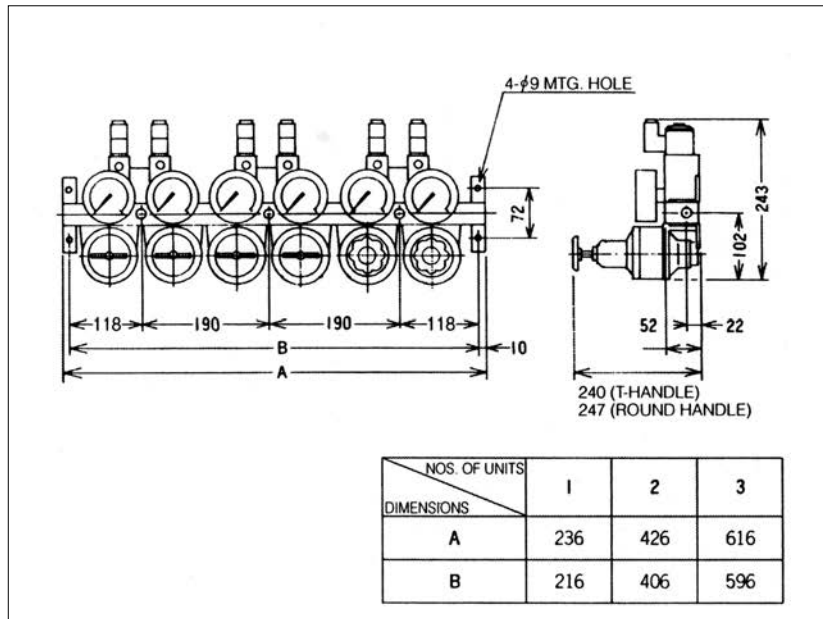
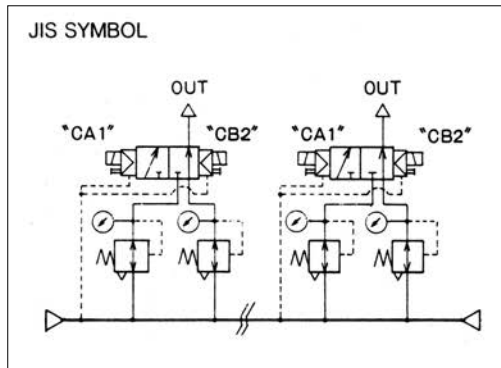

HIGH SET

H30/H50 SERIES (DIGITAL PRESSURE SETTING for Large Volume Tank)



CONTROL BOX

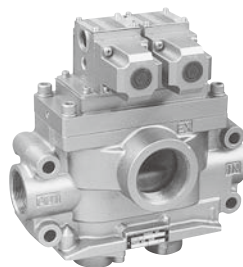

CONTROL VALVE



P/I CONVERTER

SPECIFICATIONS

OPERATING FLUID	Filtered compressed air (by filter 74μm or less)
SUPPLY PRESSURE to INLET	0.2~0.95MPa
SETTING PRESSURE RANGE	0.1~0.95MPa (Min. pressure increment: 0.01MPa) *1
SET PRESSURE ACCURACY	±1% F. S. (at 25°C)
SUPPLY VOLTAGE	DC24V/AC100V(±10%): for H30 Series Controller *2 AC100V(±10%): for H50 Series Controller DC24V(±1V): for P/I Converter AC100V/ DC24V (±10%): for H18/1B Control Valve *3
	DC24V (±10%): for GOOD signal output DC24V (±10%): for Interlock signal output
INPUT SIGNAL to CONTROLLER	H30 Series: BCD parallel or shift key on front H50 Series: 0 – 10VDC signal
AMBIENT TEMPERATURE	5~50°C
AMBIENT RELATIVE HUMIDITY	RH20~85% (Forming of ice is prohibited)
VIBRATION PROTECTION	Controller Unit needs vibration protection.
Mass (kg)	Controller: 2.5kg/ H30, or 0.5kg/ H50 P/I Converter: 0.4kg Control Valve: 4kg/H18, or 8.8kg/H1B

*1. Never exceed 0.95MPa during the compress stage of Press work.

*2. H30 Series controller can select the models built-in DC24V supply voltage for use of external equipment.

*3. Lubrication of the control valve is necessary by ISO VG32 turbine oil.

MODEL NUMBERS OF MAIN MODELS

IN/OUT Port Size	Air Tank Volume(m ³)	Model Numbers of the System	Equipments Composing Electronic High Set System			
			Controller	(Supply Voltage)	Control Valve	P/I Converter
Rc1	0.3~3	H38-801-07A0	H30-001-70A0	AC100V (w/Auxiliary DC24V)	H18-800-1000 (Port size: Rc1) (EX port: Rc1 1/4)	S12-201-0000 (Pipe Size: R 1/4)
		H38-801-07C0	H30-001-70C0			
		H38-801-070W	H30-001-700W	AC100V and DC24V		
		H38-801-07BW	H30-001-70BW			
		H58-800-0000	H50-000-2000			
Rc1 1/2	more than 1.1	H3B-B01-07A0	H30-001-70A0	AC100V (w/Auxiliary DC24V)	H1B-B00-1000 (Port size: Rc1 1/2) (EX port: Rc2)	
		H3B-B01-07C0	H30-001-70C0			
		H3B-B01-070W	H30-001-700W	AC100V and DC24V		
		H3B-B01-07BW	H30-001-70BW			
		H5B-B00-0000	H50-000-2000			

ELECTRONIC HIGH-SET SYSTEM DIAGRAM

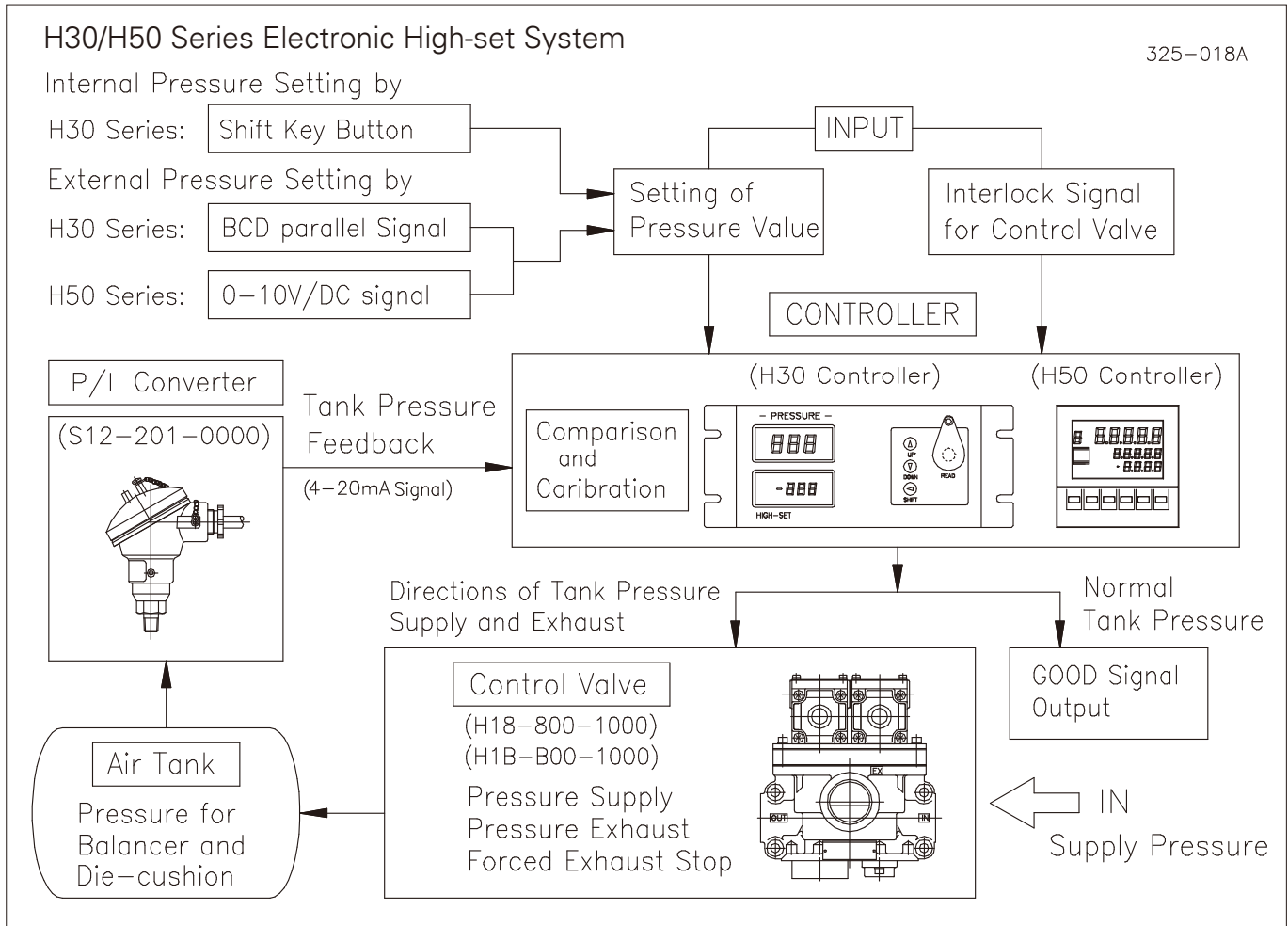

H30 EASY PRESSURE SETTING BY SHIFT KEY BUTTON

The best pressure setting is available with simple buttons operation.

SHIFT moves digit position for setting.
 UP /DOWN changes numeral for setting.
 READ: Controller reads into the set value.

The control panel features a digital display showing '888' and '-888'. It includes buttons for UP, DOWN, and SHIFT, along with a READ button. A detailed view shows the physical layout of these buttons.

SELECTION GUIDE OF CONTROL VALVE

TANK VOLUME	Model No. of CONTROL VALVE & AUXILIARY UNIT
0.3~1m ³	H18-800-1000 combined with SC-710 Speed Controller
1.1~3m ³	H18-800-1000 or H1B-B00-1000 combined with SC-712 Speed Controller
3.1m ³ ~	H1B-B00-1000

Controllable air pressure changing rate, in supplying and exhaust, is necessary to be within 0.03MPa/sec.
 If tank volume is small against the flow capacity (effective area) of the control valve, installing speed controller between the tank and control valve is recommended in order to reduce changing speed.

The schematic shows an Air Tank connected to a Speed Controller (port 2) and a Control Valve (port 1). The Control Valve is also connected to a tank and a pressure gauge.

BCD Parallel Input/Front Shift Key Input Type
H30 Controller

Bracket Mounting: H30-001-70BW (DC24V+AC100V)
Bracket Mounting: H30-001-70C0 (AC100V)

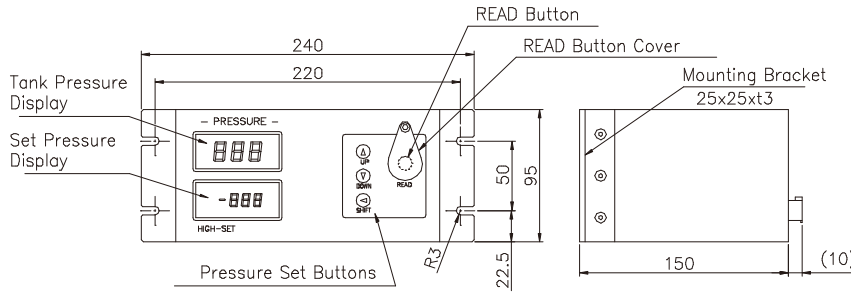

Wiring Terminal of H30 Controller (on back)
(Available for both mounting types)

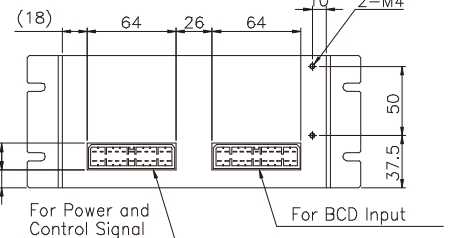

BCD Parallel Input/Front Shift Key Input type
H30 Controller

Bottom Mounting: H30-001-700W (DC24V+AC100V)
Bracket Mounting: H30-001-70A0 (AC100V)

325-011

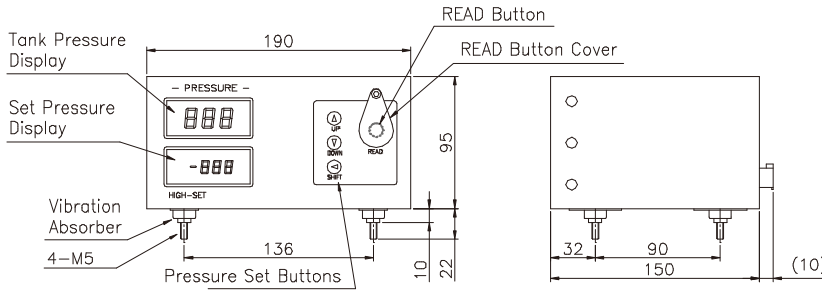

325-012

P/I Converter: S12-201-0000

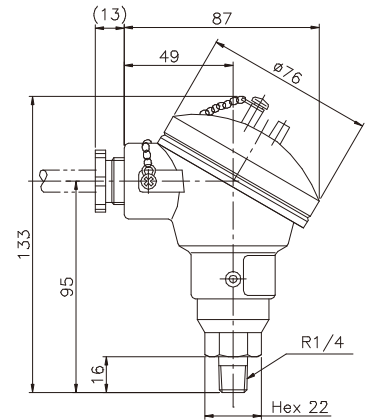

0-10V DC Voltage Input: H50-000-2000 (4 Digits Pressure Display)

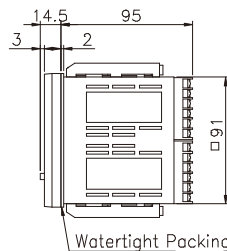
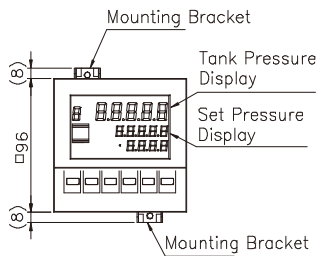

Wiring Terminal of H50
Controller (on back)

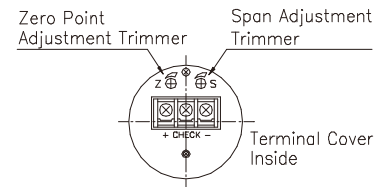
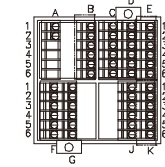

Dimensions List —mm—

	H18-800-1000	H1B-B00-1000
IN/OUT Port	Rc 1	Rc1 1/2
EX Port	Rc1 1/4	Rc 2
A	165	260
B	84	130
C	81	130
D	190	274
E	57	97
F	118	160
G	15	28
H	70	106
J	70	111
K	28.5	42
L	24	36
M	136	140
N	60	79
P	17	30
Q	42.5	46
TT	8.6	13.5
Mass (kg)	4/AC 4.8/DC	8.8/AC 9.6/DC

Add 24mm to M in list in case of DC voltage valve.
Replace 0 of 10th digit with A in case of DC voltage model (DC24V).

Control Valve: H1*-100-1000

< JIS Symbol >

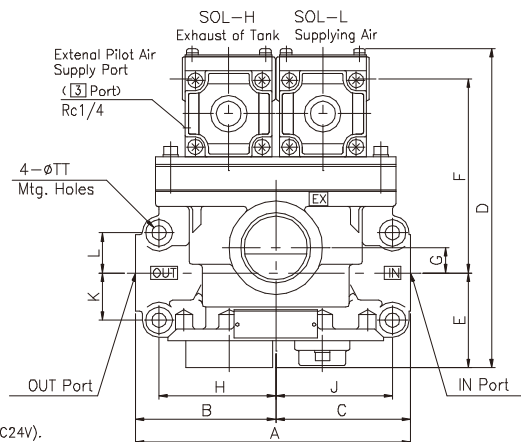

Effective Cross Section (mm²)

Model Number	IN+OUT	OUT+EX
H18-800-1000	180	210
H1B-B00-1000	530	680

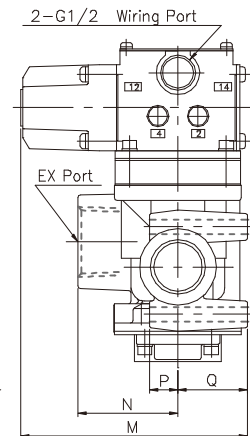

325-031

ACCESSORY FOR AIR REGULATOR

PRESSURE GAUGE

Center back connection



Bottom connection



MODEL NUMBER	SPECIFICATIONS				
	Diameter of Dial	Pressure Range	Pipe Size	Pressure Port Connection	Class
GAB501100	φ 50	0 ~ 1.0MPa	R ¹ / ₈	Center back connection	B (3% FS)
GAB501040	φ 50	0 ~ 0.40MPa	R ¹ / ₈		
GAB501020	φ 50	0 ~ 0.20MPa	R ¹ / ₈		
GBB501100	φ 50	0 ~ 1.0MPa	R ¹ / ₈	Bottom connection	
GBB501040	φ 50	0 ~ 0.40MPa	R ¹ / ₈		
GAB502100	φ 50	0 ~ 1.0MPa	R ¹ / ₄	Center back connection	
GAB502040	φ 50	0 ~ 0.40MPa	R ¹ / ₄		
GAB401100	φ 40	0 ~ 1.0MPa	R ¹ / ₈		
GAB401040	φ 40	0 ~ 0.40MPa	R ¹ / ₈		
GAB401010	φ 40	0 ~ 0.1MPa	R ¹ / ₈		
GAB501200	φ 50	0 ~ 2.0MPa	R ¹ / ₈		
GAA501100	φ 50	0 ~ 1.0MPa	R ¹ / ₈		A (1.5% FS)
GAA501020	φ 50	0 ~ 0.2MPa	R ¹ / ₈		

Examples of indication of the dial

0 ~ 1.0MPa



0 ~ 0.4MPa



0 ~ 0.2MPa



LUBRICATOR

NOL-500 SERIES (Rc¹/₄~Rc1)

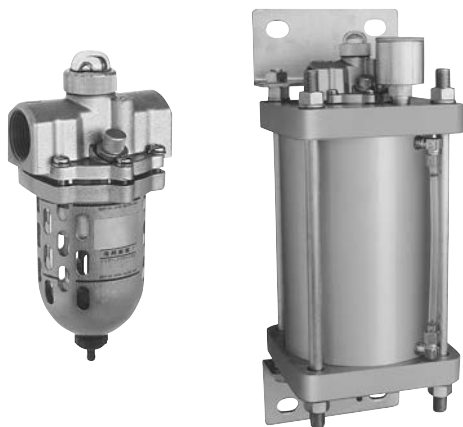

SPECIFICATIONS

FLUID	Filtered Compressed Air
OPERATING PRESSURE	max. 1.0MPa
AMBIENT TEMPERATURE	5 ~ 60°C
OPERATION	Micron Fog Lubrication
RECOMMENDED LUBRICANT	Turbine Oil ISO VG 32 or equivalent for mist lubrication

BASIC MODEL NOS. & OTHERS

Pipe Size	MODEL NUMBER	Oil Reservoir (liter)	Min. Flow Rate* for Fog Output (dm ³ /min. (ANR))	Mass (kg)
Rc ¹ / ₄	NOL-502	0.22	163	1.2
	NOL-502-1XL	1		4.4
	NOL-502-2XL	2		7.2
	NOL-502-5XL	5		13.5
	NOL-502-9XL	9		22.5
Rc ³ / ₈	NOL-503	0.22		1.2
	NOL-503-1XL	1		4.4
	NOL-503-2XL	2		7.2
	NOL-503-5XL	5		13.5
	NOL-503-9XL	9		22.5
Rc ¹ / ₂	NOL-504	0.22		1.2
	NOL-504-1XL	1		4.4
	NOL-504-2XL	2		7.2
	NOL-504-5XL	5		13.5
	NOL-504-9XL	9		22.5
Rc ³ / ₄	NOL-506	0.22		1.5
	NOL-506-1XL	1		4.7
	NOL-506-2XL	2		7.5
	NOL-506-5XL	5		14.0
	NOL-506-9XL	9		23.0
Rc1	NOL-510	0.22	1.4	
	NOL-510-1XL	1	4.7	
	NOL-510-2XL	2	7.5	
	NOL-510-5XL	5	14.0	
	NOL-510-9XL	9	23.0	

* At operating pressure 0.7MPa

HOW TO ORDER

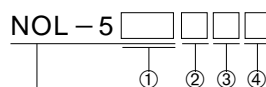

PRODUCT TYPE
MICRON FOG TYPE NOL-500 SERIES

① Pipe size

02	Rc ¹ / ₄
03	Rc ³ / ₈
04	Rc ¹ / ₂
06	Rc ³ / ₄
10	Rc1

③ Oil Reservoir / Bracket

XL	Metal cylinder with level gauge (Std.)
XLS	Metal cylinder with glass level gauge
B	with bracket for unit of bowl type

② Capacity of Oil Reservoir (nominal)

NIL	0.22 liter
1	1 liter
2	2 liter
5	5 liter
9	9 liter

④ Level Switch

NIL	without level switch (Std.)
F**	with level switch (See below list)

Additional Marks for Models with Level Switch

without Junction Box	with Junction Box		Operation of level switch	
	Right side conduit port	Left side conduit port	at Upper Limit	at Lower Limit
F20	FG20R	FG20L	—	ON
F21	FG21R	FG21L	—	OFF
F22	FG22R	FG22L	ON	ON
F23	FG23R	FG23L	OFF	OFF
F24	FG24R	FG24L	OFF	ON
F25	FG25R	FG25L	ON	OFF

Electrical connection for FG 22 ~ 25 R/L type, upper limit level switch is connected to the upper junction box. And lower limit level switch is connected to the lower junction box.

Only one level switch is available on "1L" and "2L" reservoir model. For "5L" and "9L" reservoir model. 2 level switches can be furnished on one unit.

FLOW CHARACTERISTIC CURVE

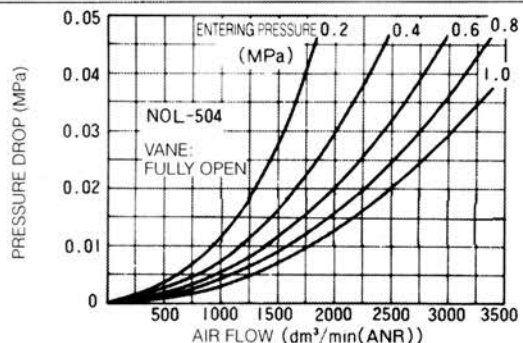
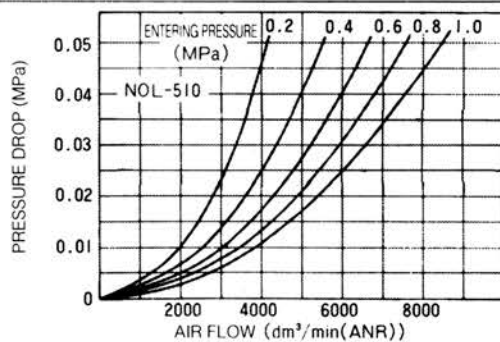
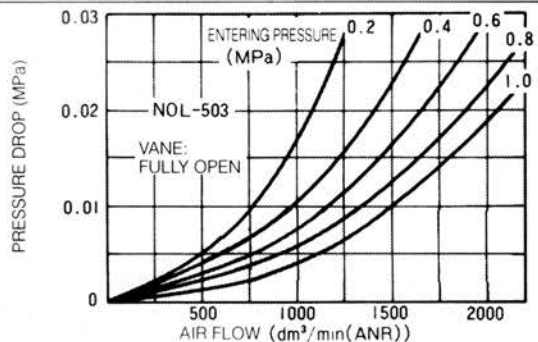
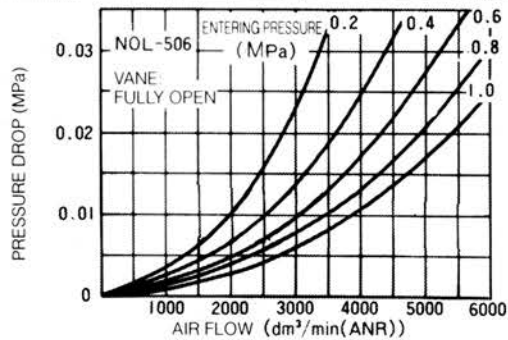
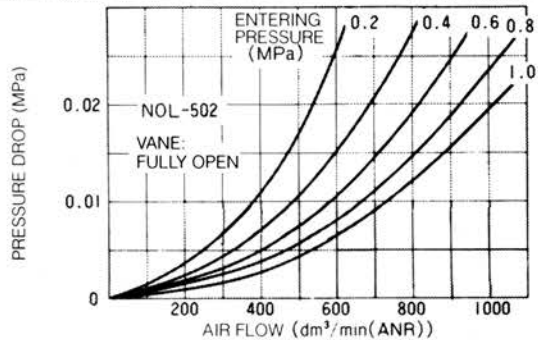

DIMENSIONS — mm —

NOL-502~510 (Rc $\frac{1}{4}$ ~Rc1)

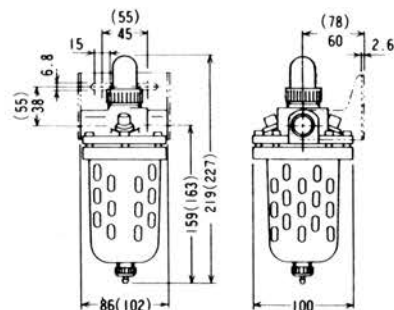

DIMENSIONS IN () ARE FOR Rc $\frac{3}{4}$, Rc1 OTHER DIMENSIONS ARE COMMON.

DIMENSIONS — mm —

NOL-500- $\frac{1}{2}$ × L (Rc $\frac{1}{4}$ ~Rc1)

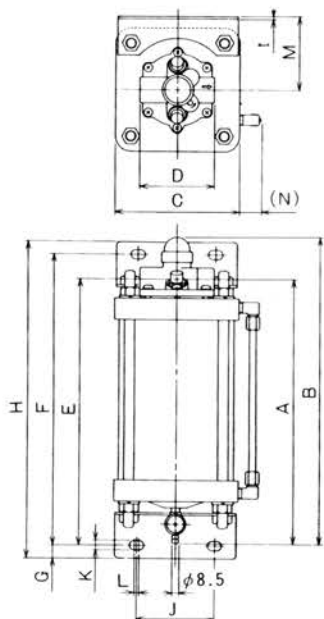

NOL-500- $\frac{5}{9}$ × L (Rc $\frac{1}{4}$ ~Rc1)

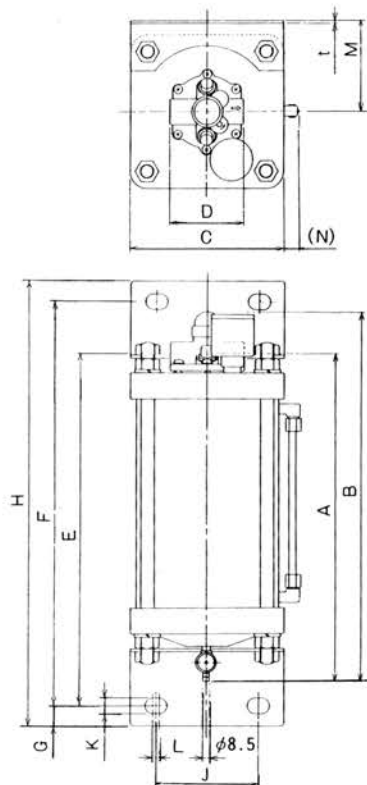

PORT SIZE	Rc $\frac{1}{4}$ ~Rc $\frac{1}{2}$				Rc $\frac{3}{4}$ ~Rc1				
	1 l	2 l	5 l	9 l	1 l	2 l	5 l	9 l	
RESERVOIR CAPACITY									
CODE OF DIMENSIONS	A	235	304	379	406	241	310	385	412
	B	283	352	427	454	294	363	438	465
	D	86				102			
	E	231	305	405	445	237	311	411	451
	C	124	144	180	250	124	144	180	250
	F	257	337	469	511	257	337	469	511
	G	15	24			15	24		
	H	287	367	517	559	287	367	517	559
	J	55	90	120	160	55	90	120	160
	K	6.8	11	18		6.8	11	18	
	L	15	9	8		15	9	8	
	M	68	85	107	131	68	85	107	131
	t	2.3	2.3	3.2	4.5	2.3	2.3	3.2	4.5
N	20	25	15	18	20	25	15	18	

MICRON LUB

Micron-fog lubricator for machine lubrication NOL-800 Series (Rc¹/₄~Rc¹/₂, 8~100BI)

MODEL NUMBERS & SPECIFICATIONS

Model Numbers	NOL-802-1XLFG21R	NOL-802-2XLFG21R	NOL-804-5XLFG21R	NOL-802-2XLFG21
Lubrication Capacity	8 ~ 32BI		20 ~ 100BI	
Pipe Sizes	Rc1/4		Rc1/2	
Operating Fluid	Oil removed clean compressed air			
Operating Pressure	0.04 ~ 0.2MPa			
Lubricating Oil	Oil for mist lubrication, and ISO VG100 maximum oil viscosity			
Reservoir Capacity (Effective)	0.6dm ³	1.4dm ³	4.2dm ³	8.4dm ³
Air Consumption	70dm ³ /min(ANR)		80dm ³ /min(ANR)	
Ambient Tempm.	5 ~ 50°C			
Oil Level Switch	makes contact at lower oil level, capacity: 0.5A/AC 100v (resistance load)			
Mass (about)	5kg	8kg	15kg	25kg

Note:

*1. Lubricating oil should be suitable for the mist lubrication.

*2. Air consumption in the table is in the case at 0.2MPa operation pressure. Air consumption changes with Manifold pressure and the number of Fog-nozzles (=reclassifiers).

*3. Use these lubricator units within specifications.

DIMENSIONS

—mm—

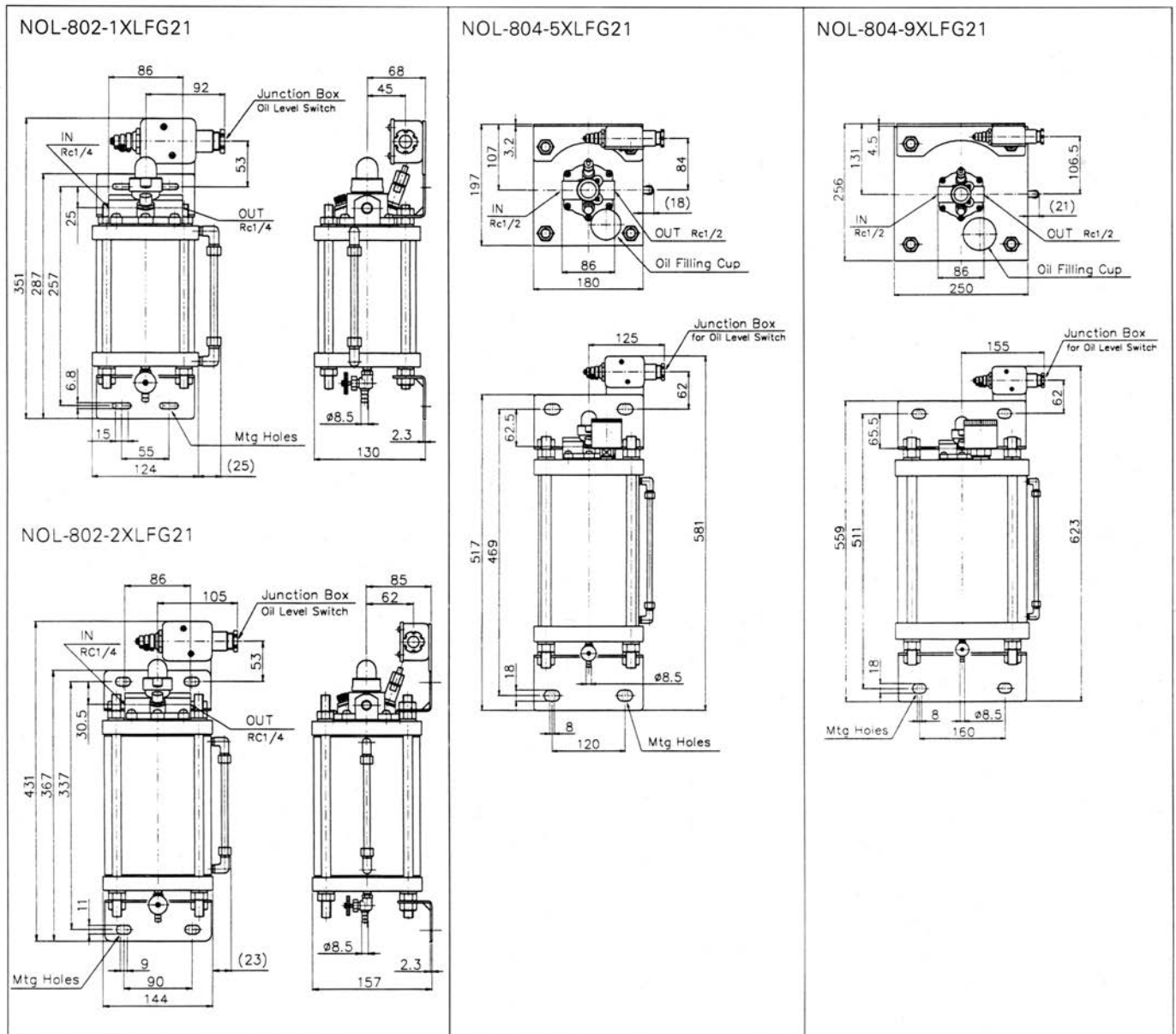

CHARGE TANK

OT-※002YXL (Rc¹/₄)



SPECIFICATIONS

FLUID	Pressurizing Fluid: Filtered Compressed Air Pressurized Fluid: Oil, Cutting Oil, etc.
OPERATING PRESSURE	max. 1.0MPa
AMBIENT TEMPERATURE	5 ~ 60°C
PIPE SIZE	Pressure Air Inlet Port: Rc ¹ / ₄ Oil Outlet Port : Rc ¹ / ₄

BASIC MODEL NOS. & OTHERS

Pipe Size	MODEL NUMBER	Oil Reservoir (liter)	Mass (kg)
Rc ¹ / ₄	OT-1002YXL	1	5
	OT-2002YXL	2	8
	OT-5002YXL	5	15
	OT-9002YXL	9	24

HOW TO ORDER

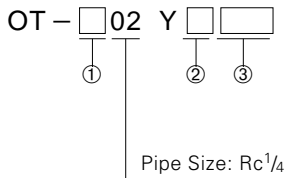

① Oil Tank Capacity (Nominal, dm ³)	
10	1dm ³
20	2dm ³
50	5dm ³
90	9dm ³

② Oil Tank	
XL	Metal Cylinder (Std)
XLS	w/Glass Level Gauge

③ Level Switch				
Nil	Without Level Switch (Std)			
Marks of Level Switches for Charge Tank with Level Switch				
Without Junction Box	With Junction Box		Action of Level Switch	
	at Right Side	at Left Side	at Upper Limit	at Lower Limit
F20	FG20R	FG20L	—	ON
F21	FG21R	FG21L	—	OFF
F22	FG22R	FG22L	ON	ON
F23	FG23R	FG23L	OFF	OFF
F24	FG24R	FG24L	OFF	ON
F25	FG25R	FG25L	ON	OFF

In case of Charge Tanks with level switch of FG22-25R/L, level switch for upper limit connected to junction box of upper side, and for lower limit is lower side.

DIMENSIONS -mm-

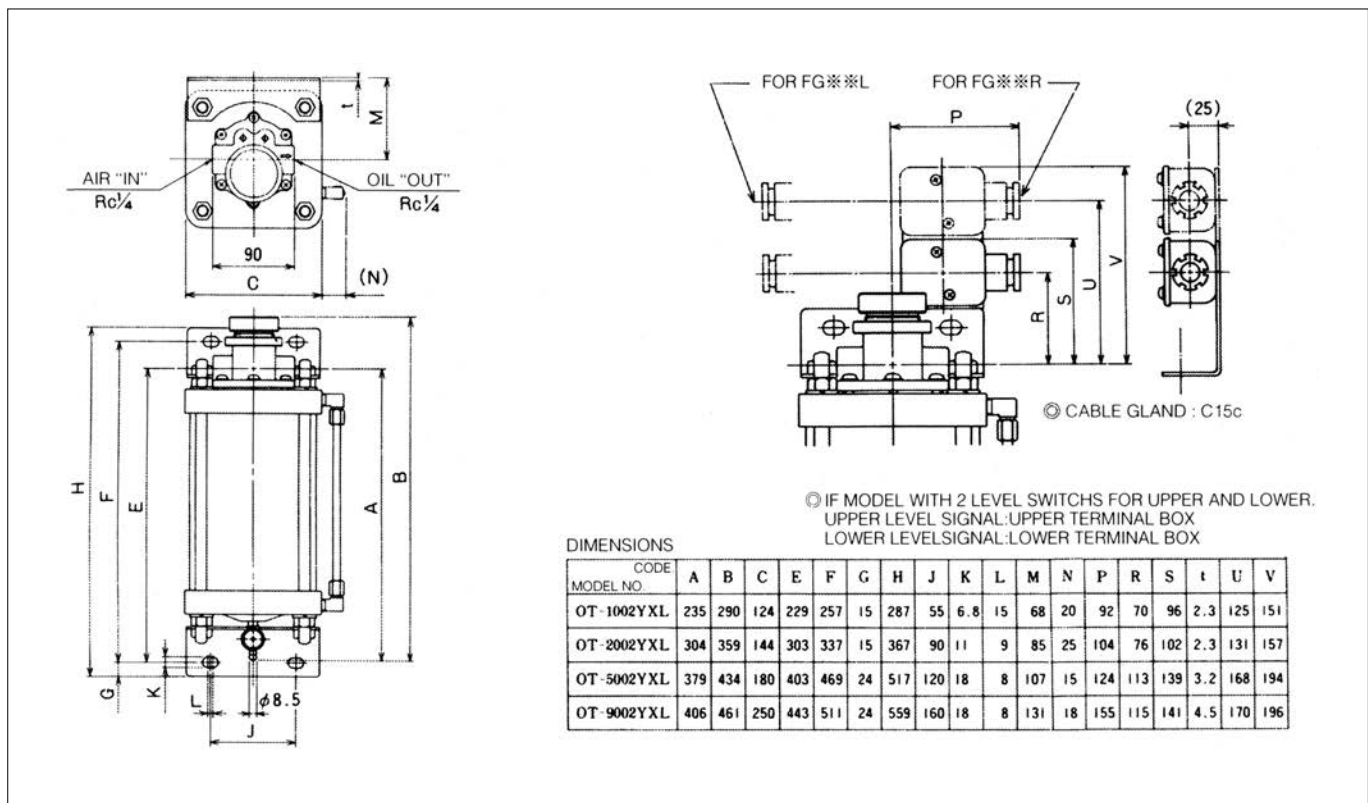

SPRAY SYSTEM

SPRAY SYSTEM

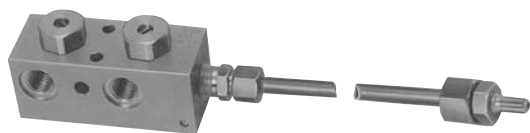

SPECIFICATIONS

FLUID	Filtered Compressed Air
OPERATING PRESSURE	0.03 ~ 1.0MPa
AMBIENT TEMPERATURE	5 ~ 60°C
PIPE SIZE	Rc ¹ / ₄ (Air & Liquid port)
RECOMMENDED LUBRICANT	Machinery Lubricant, Weak Alkaline Water Solution Emulsion, Vegetable Cutting Lubricant
OUTPUT OIL AMOUNT	1 ~ 15cc/min. Operating Lubricant: Turbine Oil VG 32 Oil Temperature: 15°C Air Line: 0.1MPa Oil Line: 0.14MPa

EQUIPMENT COMPOSING SPRAY SYSTEM

● AIR FILTER

- Rc¹/₄
- Automatic drain type
- 5 μm filter element

● AIR REGULATOR

- Rc¹/₄
- Adjusting Pressure Range
0.02 ~ 0.8MPa
- Relieving type

● CHARGE TANK

MODEL NUMBER	Oil Reservoir	Remarks
OT-1002YXL	1 liter	<ul style="list-style-type: none"> • Inlet port Rc¹/₄ • Outlet port Rc¹/₄
OT-2002YXL	2 liter	
OT-5002YXL	5 liter	
OT-9002YXL	9 liter	

● 2 PORT SOLENOID VALVE

Pipe Size	MODEL NUMBER	Effective Area
Rc ¹ / ₄	MVS-2202Y	35mm ²
Rc ³ / ₈	MVS-2203Y	40mm ²
Rc ¹ / ₂	MVS-2204JY	40mm ²

● CONTROL VALVE

MODEL NUMBER	Nozzle	Remarks
SLC-1-500	Fan type	Type with concentric tubing
SLC-2-500	Conical type	
SLC-1-0	Fan type	Directly fixed type
SLC-2-0	Conical type	
SLC-101-616	Female fitting (Rc ¹ / ₈)	Type for tube joint
SLC-102-616	Female fitting (Rc ¹ / ₄)	

Spray System Schematics

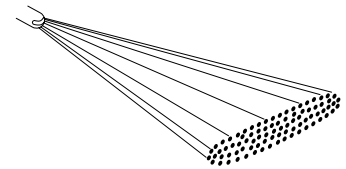
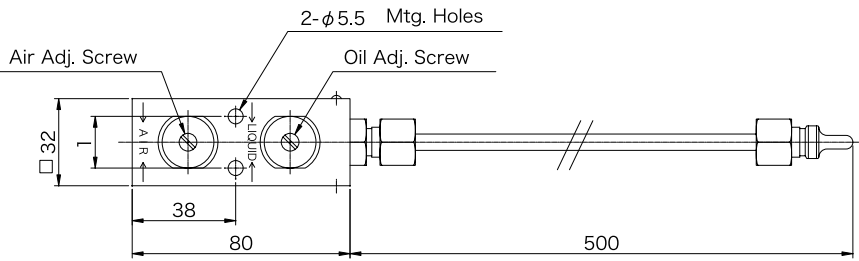
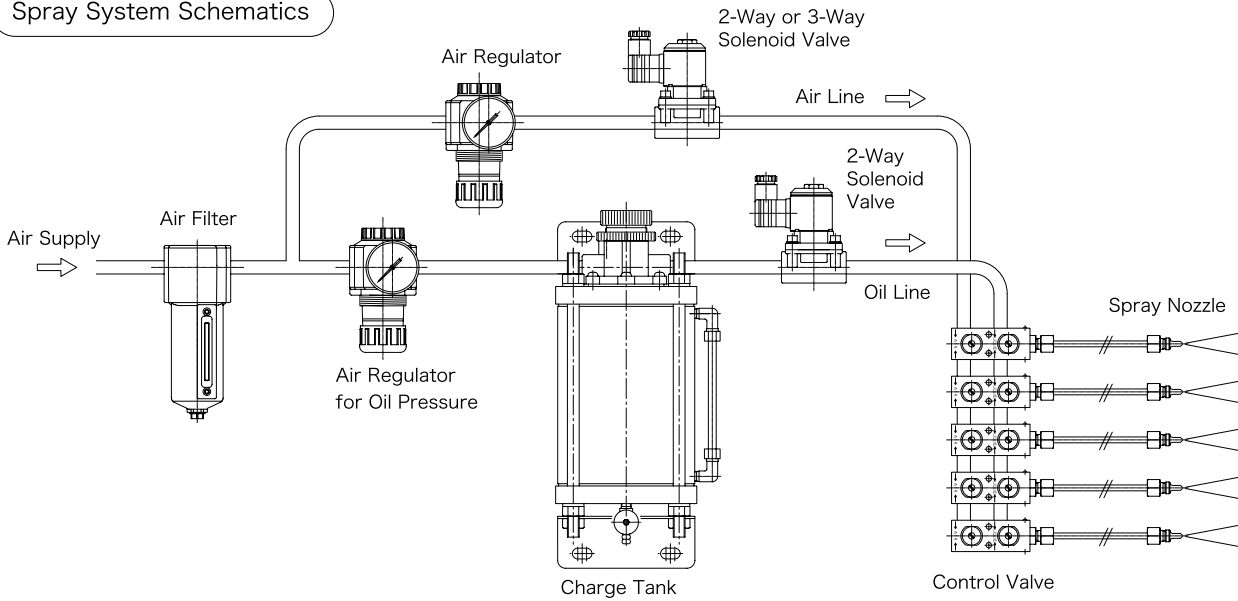

Fan Spray Nozzle

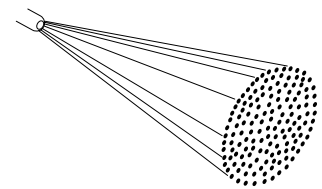
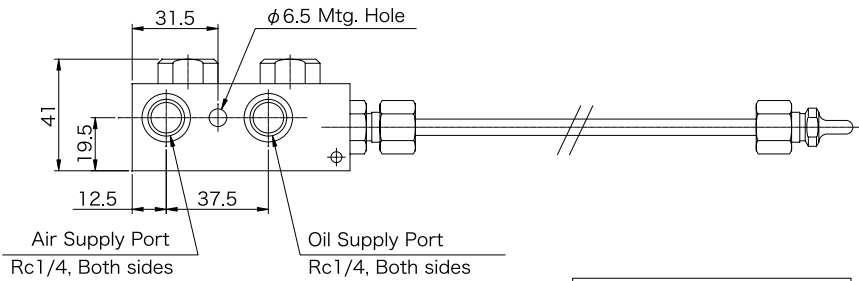

Conical Spray Nozzle

SLC-1-500/SLC-2-500

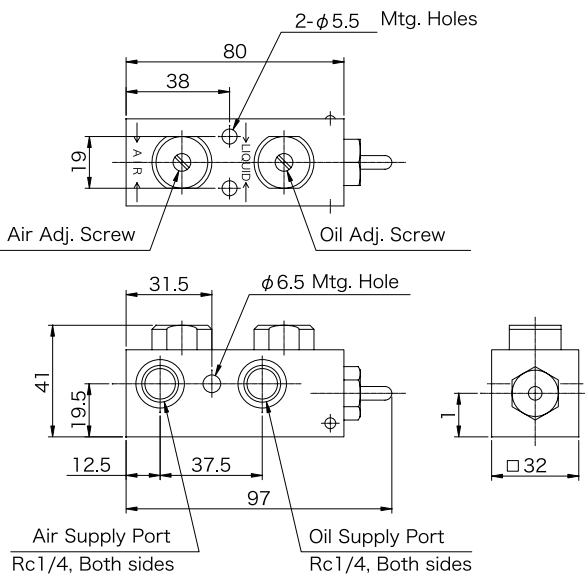

SLC-1-0/SLC-2-0

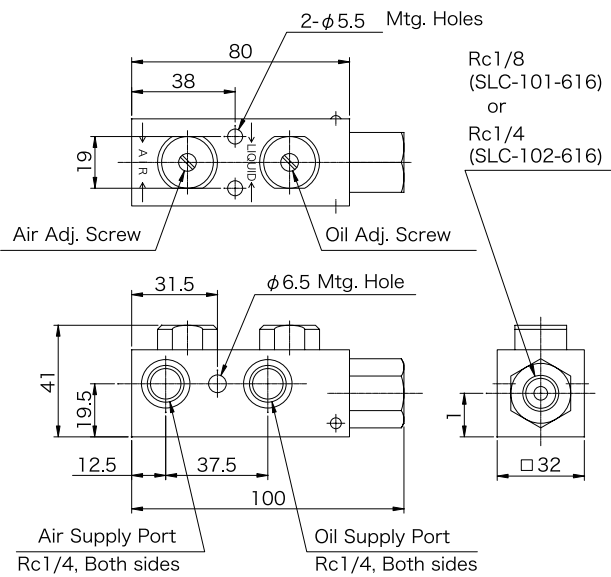

SLC-101-616/SLC-102-616

REDUCES SHOP FLOOR OPERATING COSTS.

CONSIDERABLE SAVING IN MAINTENANCE COSTS.

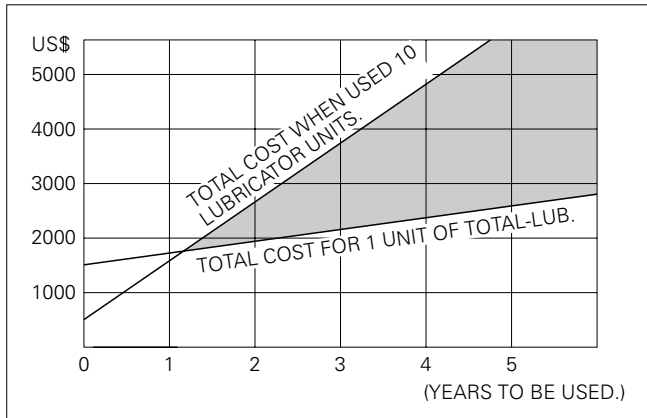

CHART 1

CONSISTENT FLOW OF LUBRICANT MIST THROUGHOUT AIR FEED LINE.

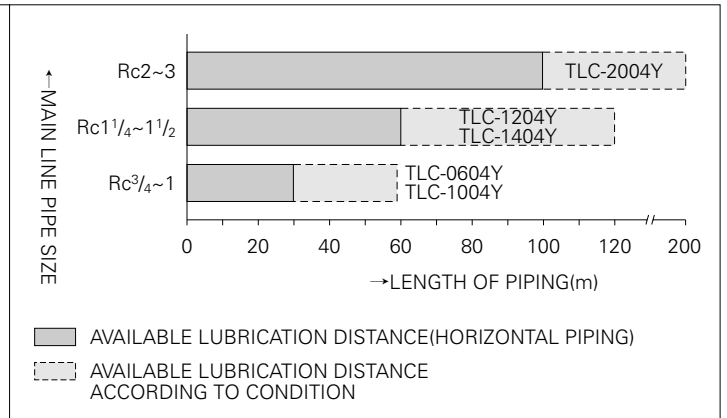
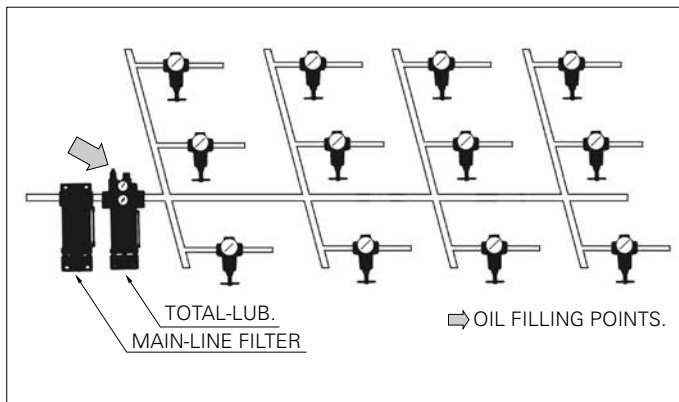
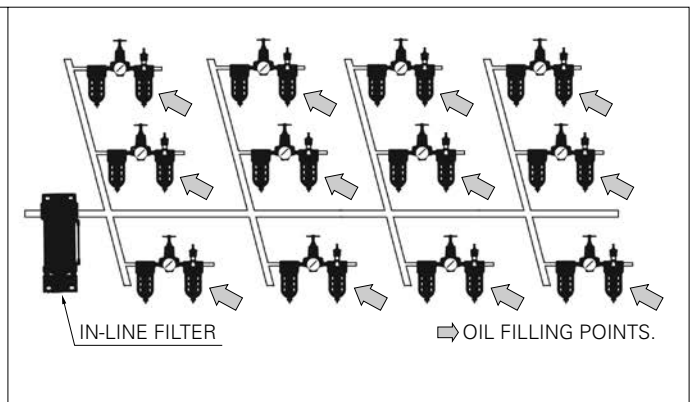

CHART 2

TOTAL-LUB SYSTEM



STANDARD LUBRICATION METHODS



AIR FLOW RANGE FOR TOTAL-LUB.

MAIN LINE PIPE SIZES	AIR FLOW SUPPLYING PRESSURE	MIN. OPERATING AIR FLOW dm ³ /min (ANR)			MAX. RECOMMENDED AIR FLOW dm ³ /min (ANR)		
		0.3MPa	0.5MPa	0.7MPa	0.3MPa	0.5MPa	0.7MPa
Rc ³ / ₄					2,400	2,900	3,300
Rc1					3,900	4,800	5,600
Rc1 ¹ / ₄	50	60	70		6,300	7,700	8,800
Rc1 ¹ / ₂					8,400	10,300	11,800
Rc2					14,700	18,000	20,700

Air Line Centralized Lubrication Unit TLC & TLB SERIES

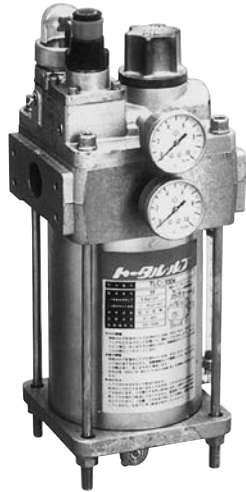

TLC SERIES

SPECIFICATIONS

MODEL NUMBER	TLC-※※04	TLB-※00-50B※
FLUID	Filtered Compressed Air (filtered air with 74μm element)	
MAX. INLET PRESSURE	1.0MPa	
OUTLET PRESSURE RANGE	0.1 ~ 0.7MPa	0.1 ~ 0.95MPa
AMBIENT TEMPERATURE	5 ~ 60°C	
RELIEF	Non relieving	
RECOMMENDED VISCOSITY RANGE FOR OIL	ISO VG 32 ~ 38 (Turbine Oil or equivalent for mist lubrication)	
MAX. OIL OUTPUT	25cc/h	

BASIC MODEL NOS. & OTHER SPECIFICATIONS

Pipe Size	MODEL NUMBER	Oil Reservoir	Mass
Rc ³ / ₄	TLC-0604	2 liter	11.5kg
Rc1	TLC-1004		
Rc1 ¹ / ₄	TLB-A00-50B0	5 liter	14kg
Rc1 ¹ / ₂	TLB-B00-50B0		
Rc2	TLB-C00-50B0		

*When ordering TLC model with Min. Oil Level Switch, following FG ※※ should be added at the end of model number, Junction box for electrical connection is equipped.

*When ordering TLB model with Min. oil level switch, replace 0 by 4 or C at the end of model number.

Additional No. (Replaced by)	Operation of Oil Level Switch	Contact Point Capacity
FG20 (4)	"ON" at min. oil level	Single pole Single throw 120mA/AC100V; 60mA/AC200V
FG21 (C)	"OFF" at min. oil level	

EX: TLC-2004YFG21/TLB-B00-00BC.
(TLC-2004Y/TLB-B00-00B0 with min. oil level switch which is turned off at min. oil level.)

JIS SYMBOL OF THE SYSTEM

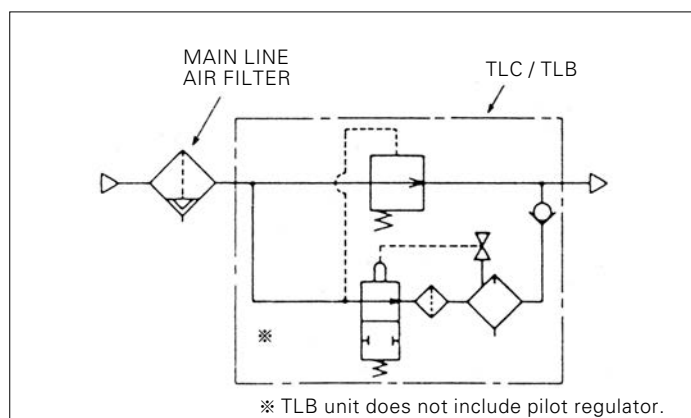

Pipe Size	Main Line Air Filter
Rc ³ / ₄	NAF-606
Rc1	NAF-610
Rc1 ¹ / ₄	NAF-512XL
Rc1 ¹ / ₂	NAF-514XL
Rc2	NAF-520XL

Main line filter should be installed at primary side of TLC/TLB.
Select air filter from the table according to the pipe size in use.

TLC-0604/1004

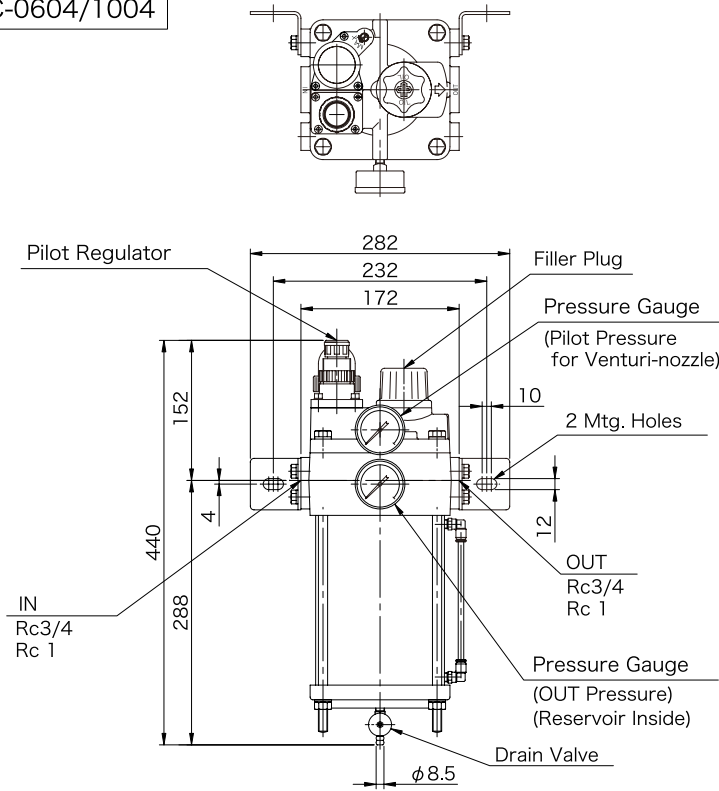

CIRCUIT of TLC-0604/-1004

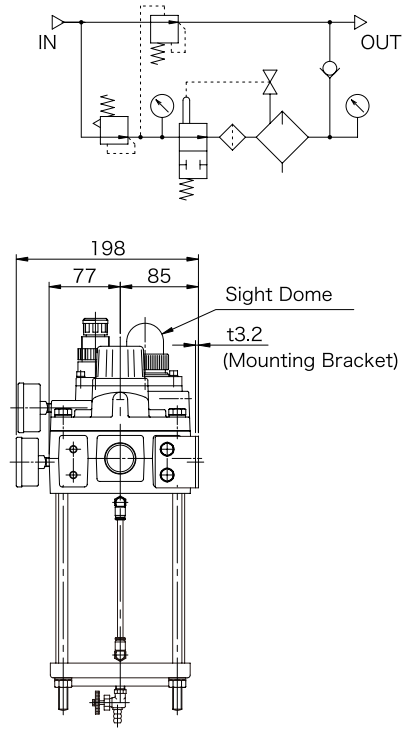

330-014

TLB-*00-50B*

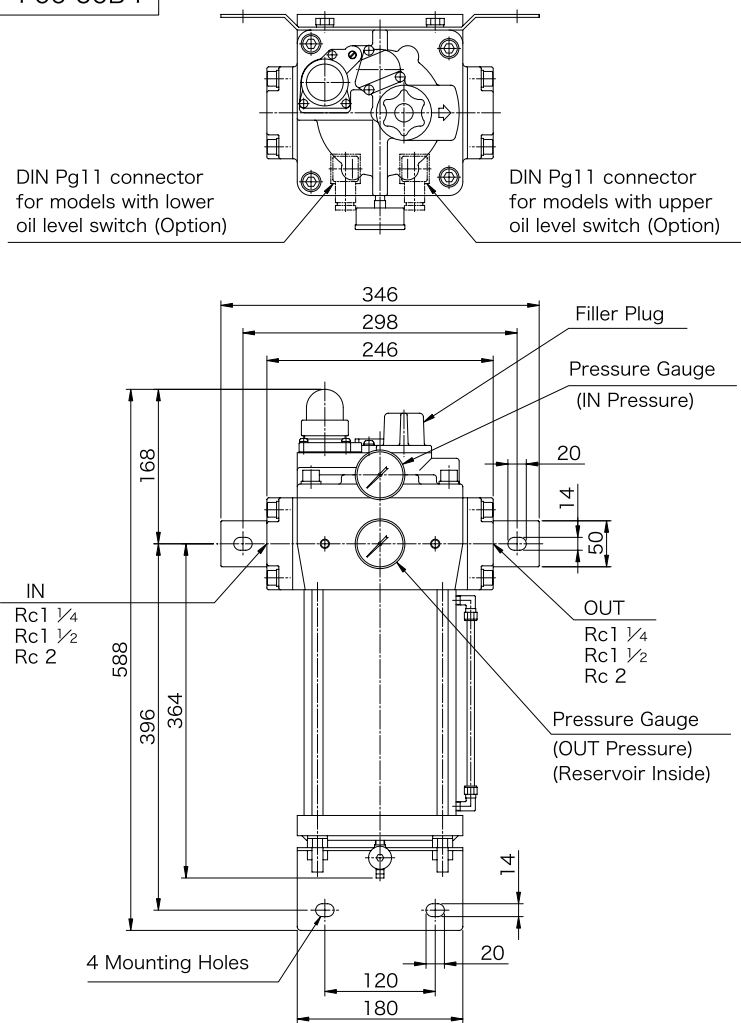

CIRCUIT of TLB-*00-50B*

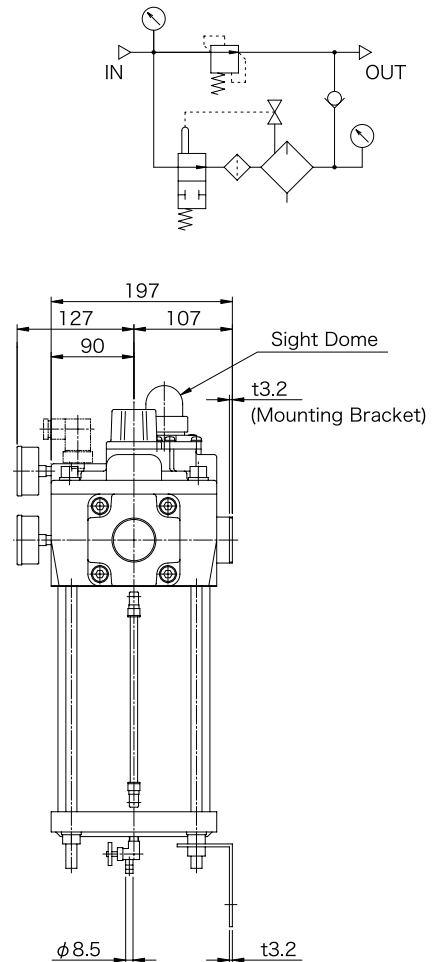

330-016

(By Dwg 330-014, -016)

TOTAL LUB

Air Line Centralized Lubrication Un

TLD SERIES (and TCU Control Box, NBA By-pass Adapter)



SPECIFICATIONS & MODEL NUMBERS - TLD

MODEL NUMBER	TLD-S104	TLD-S204
PIPE SIZE	Air Supply Port : Rc ¹ / ₄ Micron Fog Outlet Port: Rc ¹ / ₂	
FLUID	Compressed Air (Cleaned and filtered with 74 micron element. Clean air filtered by 25 micron air filter is needed for pressurizing line.)	
OPERATING PRESSURE RANGE	0.3 ~ 0.8MPa	
RECOMMENDED OIL	ISO VG 32 Turbine oil or equivalent for mist lubrication	
MAX. OIL OUTPUT	22cc/h	
MASS	25kg	
RATED VOLTAGE	AC-100V 50/60Hz, 110V 60Hz	AC-200V 50/60Hz, 220V 60Hz
VOLTAGE ALLOWANCE	-15 ~ +10%	
INSULATION GRADE	Class "B"	

DIMENSIONS -mm-

330-018

Total-Lub Unit - TLD Series

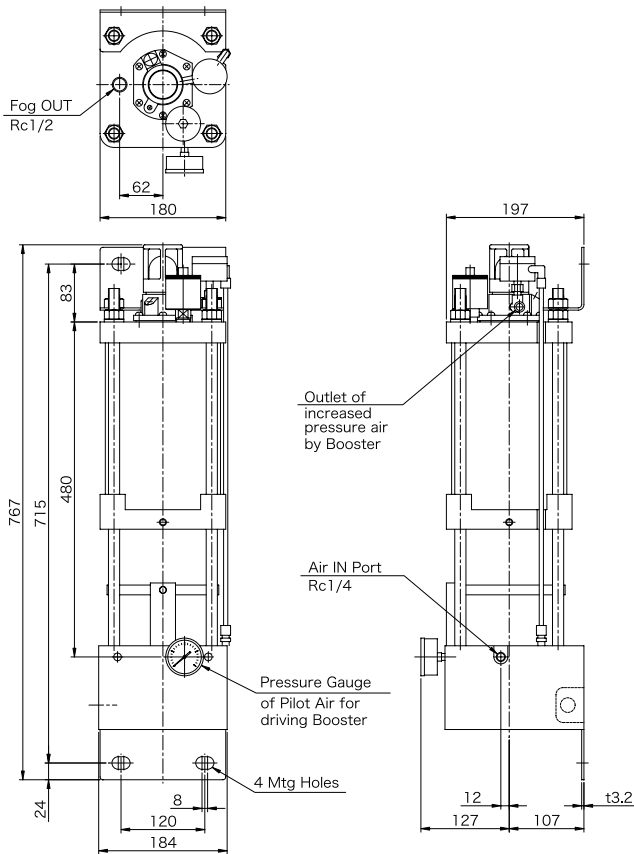

Schematics of TLD Total-Lub System

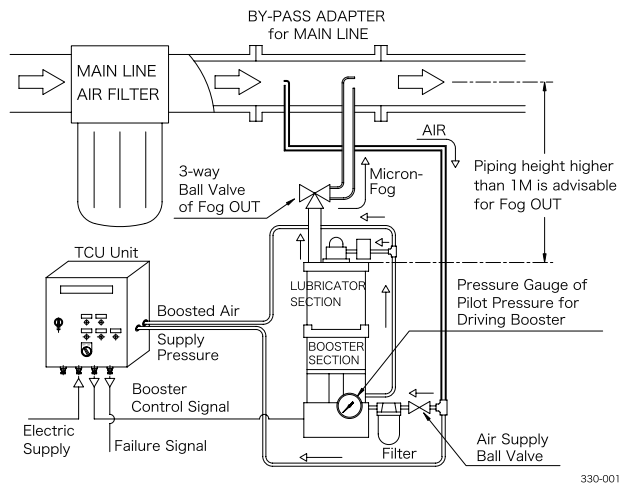

330-001

Schematic Circuit of TLD Total-Lub System

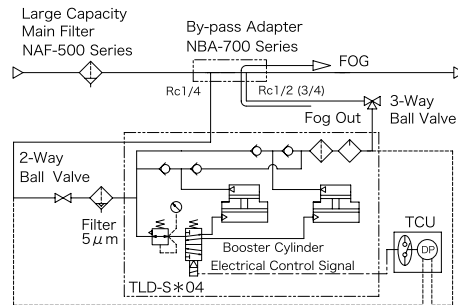

By-pass Adapter - NBA Series

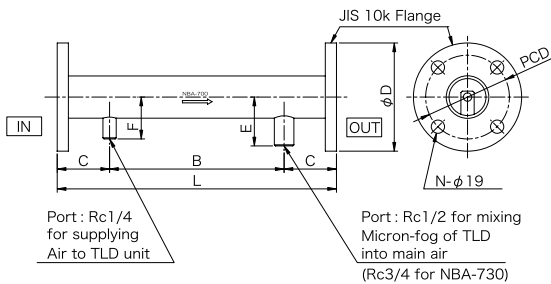

Model No.	JIS Flange	φD	L	B	C	E	F	N	PCD	Mass
NBA-712	10k 32A	135	300	150	75	60	51	4	φ100	4.3kg
NBA-714	10k 40A	140	400	250	75	60	54	4	φ105	5.8
NBA-720	10k 50A	155	400	250	75	70	60	4	φ120	6.5
NBA-724	10k 65A	175	500	350	75	75	68	4	φ140	10
NBA-730	10k 80A	185	500	350	75	80	75	8	φ150	11

Control Unit for TLD/TLE Total-Lub

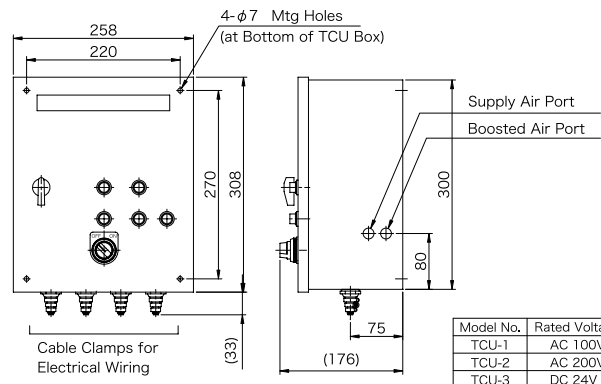

Model No.	Rated Voltage
TCU-1	AC 100V
TCU-2	AC 200V
TCU-3	DC 24V

Air Line Centralized Lubrication Unit with Electrical Control Box C08-0116

SPECIFICATIONS

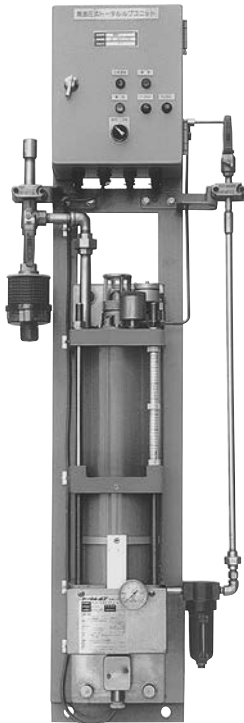

PIPE SIZE	Air Supply Port : Rc1/4 Micron Fog Outlet Port : Rc1/2
FLUID	Compressed Air (Cleaned and filtered with 74 micron element)
OPERATING PRESSURE RANGE	0.3 ~ 0.8MPa
RECOMMENDED OIL	ISO VG32 Turbine oil or equivalent for mist lubrication
MAX. OIL OUTPUT	22cc/hour
MASS	
RATED VOLTAGE	AC-100V 50/60Hz, 110V 60Hz AC-200V 50/60Hz, 220V 60Hz
VOLTAGE ALLOWANCE	-15 ~ +10%

Note: Following by-pass adaptor must be prepared separately by user.

MAIN AIR LINE SIZE	MODEL NUMBER
1B	NBA-712*
1¼B	NBA-712
1½B	NBA-714
2B	NBA-720

* Use 1¼ x 1 B bushing

DIMENSIONS -mm-

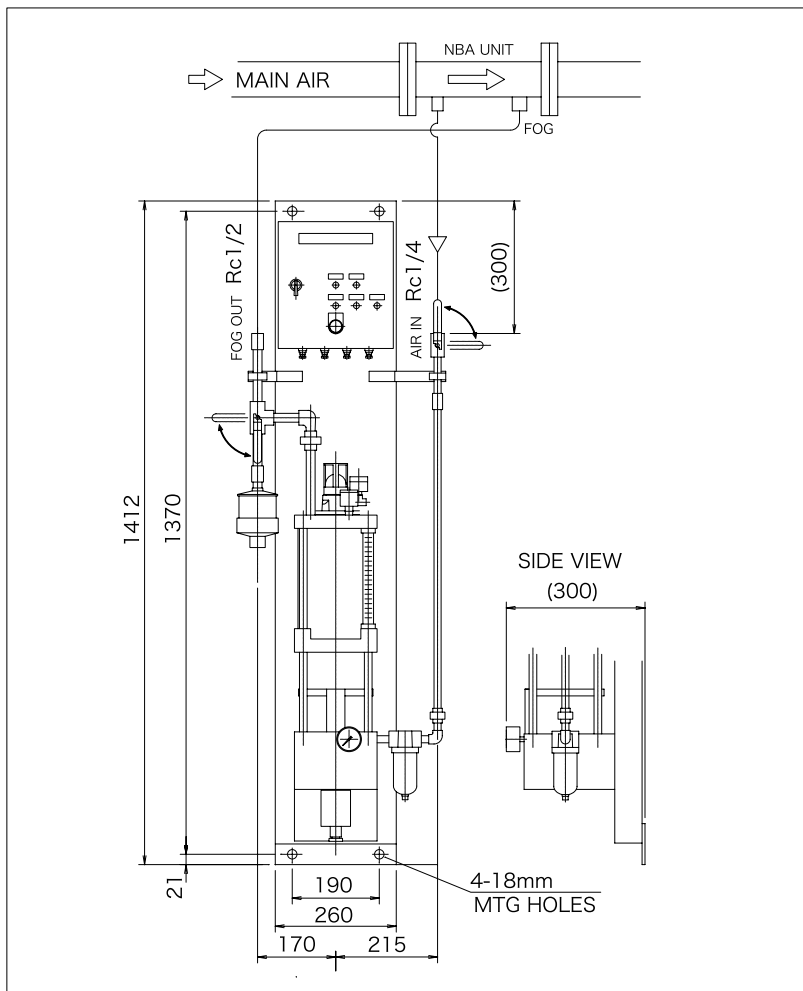

TOTAL LUB

Air Line Centralized Lubrication Unit with Air Booster TA4 SERIES



SPECIFICATIONS

PIPE SIZE	Air Supply Port : Rc1/2 Micron Fog Outlet Port : Rc1/2
FLUID	Compressed Air (Cleaned and filtered with 25 micron element)
OPERATING PRESSURE	0.2 ~ 0.5MPa
RECOMMENDED OIL	ISO VG32 Turbine oil and/or equivalent for mist lubrication
RESERVOIR CAPACITY	9 Liter
MASS	60kg

Note: Following main air filter and by-pass adaptor must be prepared separately by user.

MAIN LINE PIPE SIZE	MAIN AIR FILTER	BY-PASS ADAPTOR
1B	NAF-610	NBA-712*
1¼B	NAF-512XL	NBA-712
1½B	NAF-514XL	NBA-714
2B	NAF-520XL	NBA-720

* Use 1¼ B x 1 B bushing

HOW TO ORDER

TA4-00-9000

LEVEL SWITCH

NOS.	MAX.	MIN.
0	NO LEVEL SWITCH	
4	—	ON
5	ON	—
6	ON	ON
C	—	OFF
D	OFF	ON
E	OFF	—
F	OFF	ON
G	ON	OFF

DIMENSIONS —mm—

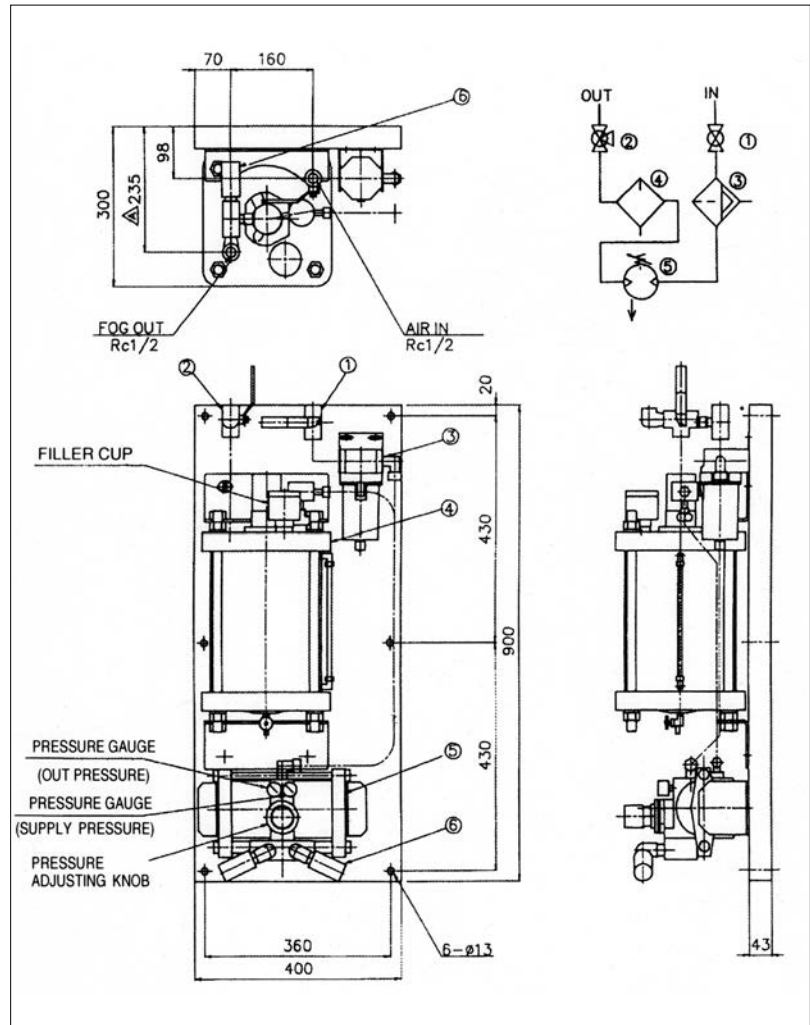

MICRON LUB

CPL Micron-lub lubrication unit MCD series (Patented)



FEATURES.

- The whole quantity of oil drip is converted to Fog (oil mist) and is certainly sent out to the lubrication point.
- There is wide compatibility of lubricating oil with this system.
- Fog (Mist) output is stable.
There is little influence on Fog output by operating conditions change, and it can be carried out stabilized lubrication.

SPECIFICATIONS

OPERATING FLUID	Cleaned oil removed compressed air. (Use oil removal filter, and compressed air that was prepared more than quality class: 2.6.3.of the compressed air quality classification by ISO 8573-1.)
OPERATING PRESSURE	0.15 ~ 0.35MPa
MANIFOLD PRESSURE	0.03 ~ 0.25MPa
PUMP OUTPUT CAPACITY	0.015cm ³
PUMP SHOT FREQUENCY	1 shot / 3min ~ 10 shot / min
AMBIENT TEMPERATURE	5 ~ 50°C
PORT SIZE	Air Supply (IN):Rc ³ / ₈ , Micron-fog OUT: Rc ¹ / ₂
VISCOSITY RANGE OF LUBRICATING OIL	ISO VG32 ~ 68 *1
AIR CONSUMPTION	500dm ³ / min (ANR) max. *2
OIL TANK CAPACITY	1000cm ³ (effective capacity 800cm ³)
RATED VOLTAGE	AC100V, AC200V, DC24V *3
MASS	About 3.6kg (in case of MCD-01L2-*Y30/*Y31 type) About 5.0kg (in case of MCD-01L2-*Y32/*Y33 type)

*1. Lubricating oil should be suitable for the mist lubrication.

*2. The amount of air consumption changes with Manifold pressure and the number of Fog-nozzles.

*3. The level switch and a pressure switch attached can be used by AC100V or DC24V rated voltage.

*3. It is impossible to use with AC200V.

** Use this lubrication unit within specifications.

Model Number:

Model Number	D04 Filter / Regulator combined w/ Solenoid valve	Operating Pressure Switch	Manifold Pressure Switch
MCD-01L2-*Y30		○	
MCD-01L2-*Y31		○	○
MCD-01L2-*Y32	○	○	
MCD-01L2-*Y33	○	○	○

1. ○ mark in above table is device included in the unit of the model listed left column.

2. Replace * at the 8th digit of the model number with the following number to specify rated voltage.

1: AC100V 2: AC200V 3: DC24V

3. Manifold pressure gauge and oil level switch are standard items.

4. On CPL Micron-lub lubrication, in order to drive the constant oil quantity output plunger pump intermittently, a twin timer, or a programmable controller, etc. are necessary. Since such timer device is not attached except the model equipped with electrical control circuit, prepare such time device beforehand.

Terminal Nos & Connected Devices

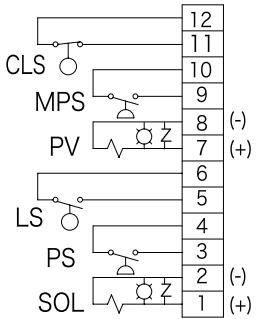

CLS	Level Switch-Fog Bowl
MPS	Manifold Pressure Switch (Option)
* PV	Pump Drive Sol. Valve
LS	Level Switch-Oil Tank
PS	Operating Press. Switch
SOL	Sol. Valve for Air Supply (integrated in D04 unit) (Option)

* Option devices are equipped with the specified models.

Note: The rated voltage for level switch and pressure switch are AC 100V or DC 24V. AC 200V is not available.

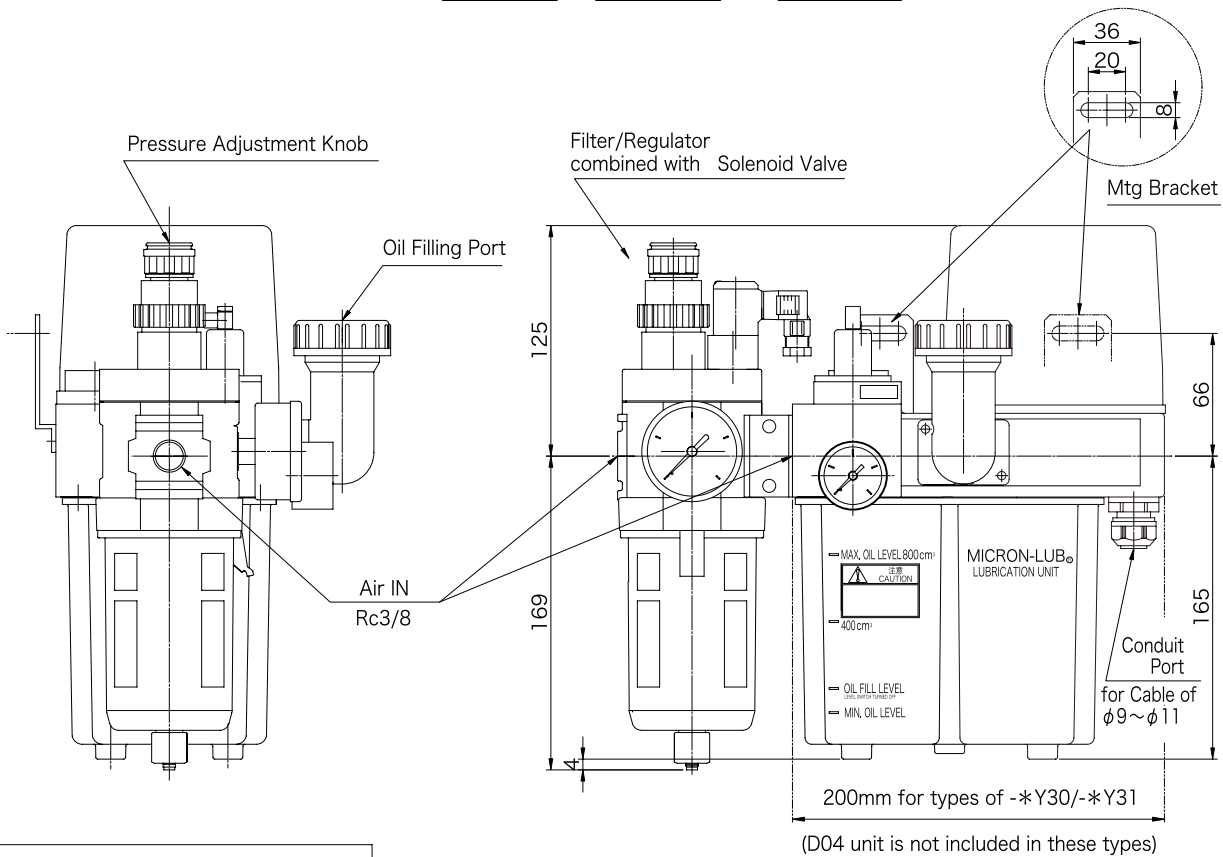
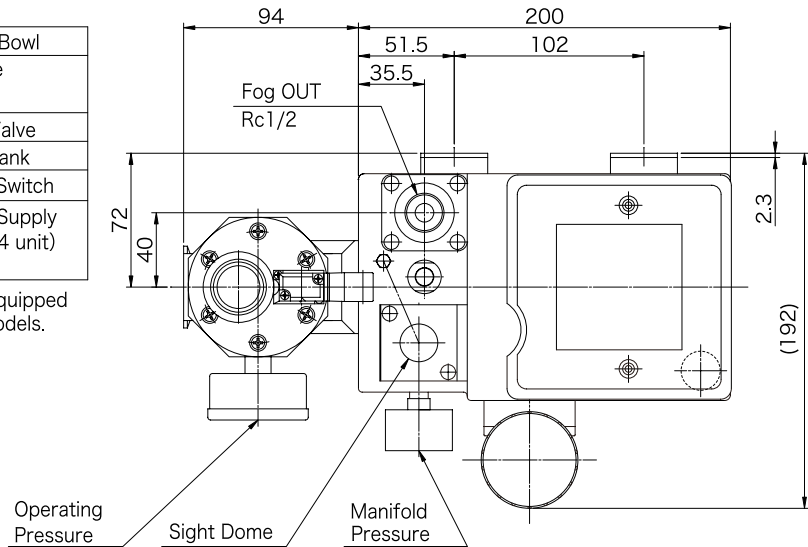

System Diagram—MCD Series

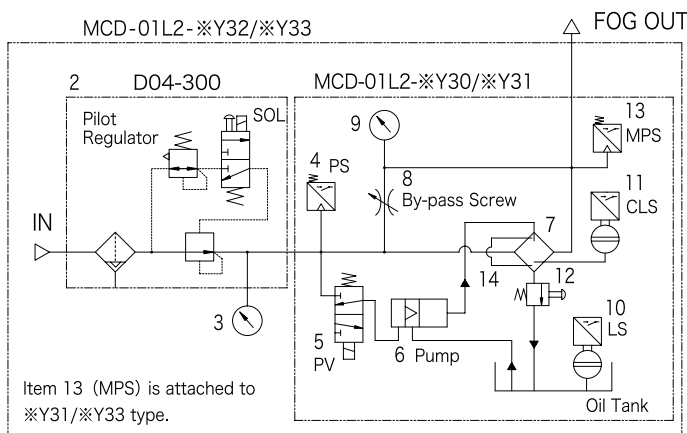

Item 13 (MPS) is attached to *Y31/*Y33 type.

No	Component Names	(Sign)
2	D04 Filter/Regulator Unit combined with Solenoid Valve	(SOL)
3	Operating Pressure Gauge	
4	Pressure Switch for operating pressure	(PS)
5	Pump drive 3-port Valve	(PV)
6	Constant Oil Discharge Pump	
7	Venturi - Micron-fog Generator	
8	By-pass Adjusting Screw	
9	Manifold Pressure Gauge	
10	Level Switch for low oil level in Oil Tank	(LS)
11	Level Switch for checking atomization	(CLS)
12	Manual Drain Valve	
13	Pressure Switch for manifold pressure	(MPS)
14	Circulate Path Tubing	



SPECIFICATIONS

FLUID	Dry compressed air filtered with 5µm element	
OPERATING PRESSURE RANGE	0.15 ~ 0.35MPa	
MANIFOLD PRESSURE RANGE	0.03 ~ 0.25MPa	*1
ENDURABLE PRESSURE	0.5MPa	
AMBIENT TEMPERATURE	5 ~ 50°C	
PORT SIZE	Air supply: Rc ³ / ₈	Fog out: Rc ¹ / ₂
LUBRICANTS	ISO VG32 ~ 68 (To be suitable for mist lubrication)	
AVAILABLE OIL SHOTS RANGE	1 ~ 20 shots/min.	
OIL OUTPUT PER SHOT BY PUMP	0.05cm ³ /one shot	
OIL RESERVOIR CAPACITY	1000cm ³ (Effective capacity: 800cm ³)	
AIR CONSUMPTION	Max. 500dm ³ /min. (ANR)	*2
RATED VOLTAGE	AC100V, AC200V, DC24V	
PROTECTION CLASS	IP54 equivalent (For basic model)	
MASS	3.7kg (5.5kg: For the unit with air control unit)	

Lubricant : Lubricant should have oil atomization characteristics compatible with mist lubrication, and recommendation or designation by machine manufacturer/bearing maker is also required.

Viscosity : Lubricants graded ISO VG32 ~ 68 are recommended. If other viscosity is required, confirm compatibility of lubricant with Micron-Lub lubrication.

Note:

*1 In case of application under 10°C of ambient temperature, adjust manifold pressure more than 0.05MPa

*2 Air consumption may be changed by using manifold pressure and quantities of Fog-Nozzle.

MODEL NOS. & OTHER SPECIFICATIONS

MODEL NUMBER	Rated Voltage	Air control equipment's	
		Filter/regulator with gauge and 2-port solenoid valve	Equipped standard items
MC9-01L3-1Y08	AC100V	Equipped	* Manifold pressure gauge
MC9-01L3-2Y08	AC200V		* Oil level switch
MC9-01L3-3Y08	DC24V		* Operating pressure switch
MC9-01L3-1Y03	AC100V	Not equipped	
MC9-01L3-2Y03	AC200V		
MC9-01L3-3Y03	DC24V		

* Twin timer or programmable controller must be separately prepared for the interval activation of oil shot pump in the Micron-Lub lubrication unit.

* Control circuit of Micron-Lub system must be made by user side.

HOW TO ORDER

MC9 - 01L3 - 3 Y 08 -

⑧
⑨
⑩
⑪

⑧ Rated Voltage

1	AC100V 50/60Hz, AC110V 60Hz
2	AC200V 50/60Hz, AC220V 60Hz
3	DC24V

⑨ Version

Y	Customized Model for Distributors
---	-----------------------------------

⑩ Option

	Pressure Switch For Manifold Pressure	Filter/Regulator W/Solenoid Valve
03	with	without
08	without	with
09	with	with

⑪ Mark

	Set of switching pressure
Nil	0.05±0.01MPa Std.
K1	0.10±0.01MPa
K1.5	0.15±0.01MPa

*If "09" is selected in 10, specify the setting of manifold pressure with mark in above table.

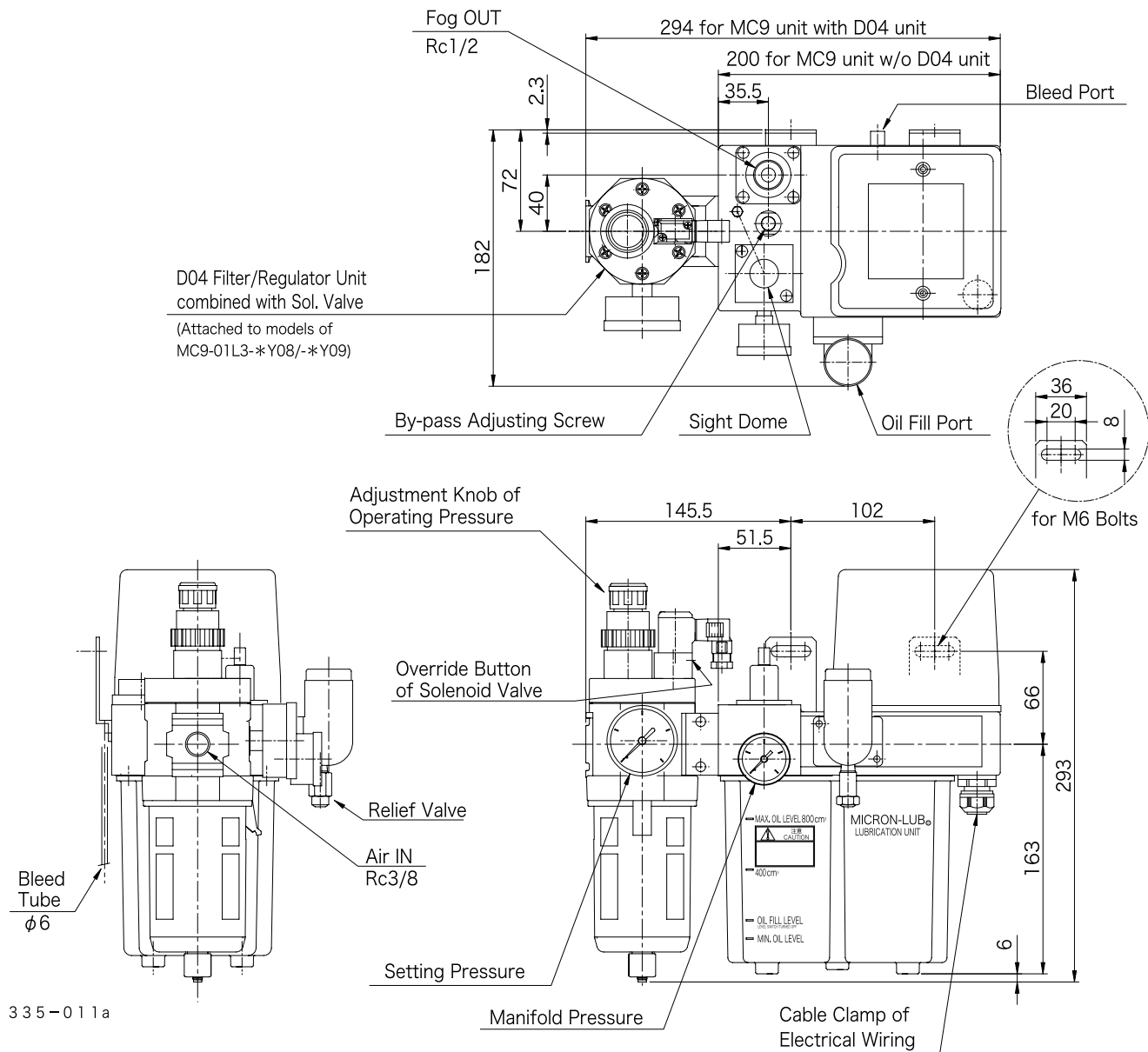

335-011a

Schematic Circuit

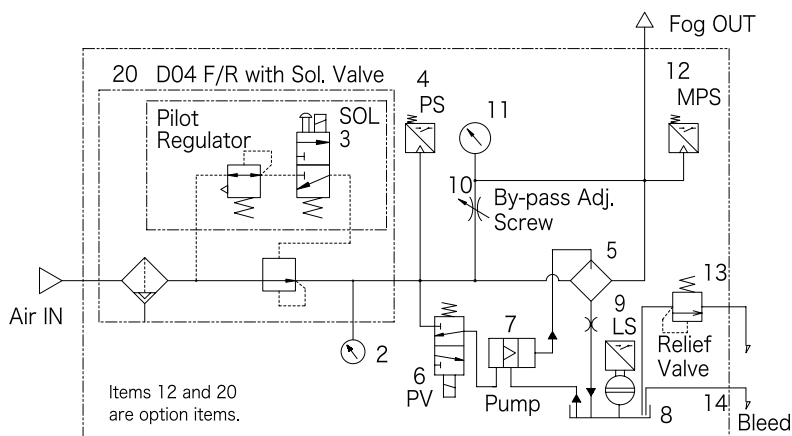

No.	Item Names
2	Operating Pressure Gauge
3	Sol. Valve for Supplying Pressure (SOL)
4	Pressure Switch of Operating Press. (PS)
5	Venturi for Generating Micron-fog
6	Sol. Valve for Driving Pump (PV)
7	Pump
8	Oil Reservoir
9	Oil Level Switch for lower level (LS)
10	By-pass Air Adjusting Screw
11	Manifold Pressure Gauge
12	Pressure Switch of Manifold Press. (MPS)
13	Relief Valve for Reservoir
14	Bleed Tube
20	D04 Filter/Regulator Unit with Solenoid Valve

MICRON LUB

CPL MICRON-LUB Lubrication Unit for Machines MC5 SERIES



MC5-02※※※S01Y



MC5-A2L※※※S01Y

SPECIFICATIONS

MODEL NO.	MC5-02H2-※※※※Y	MC5-02H4-※※※※Y
FLUID	Cleaned and dry compressed air (5μm element, oil removal filter)	
OPERATING PRESSURE RANGE	0.13 ~ 0.5MPa	
AIR INLET	Rc ³ / ₈	
MICRON FOG OUTLET	Rc ¹ / ₂	
AMBIENT TEMPERATURE	5 ~ 50°C	
RECOMMENDED VISCOSITY RANGE FOR OIL	ISO VG 32	ISO VG 32 ~ VG 68
ADJUSTABLE OIL SHOT RANGE	1 ~ 20 shot/min. (0.025cm ³ /one shot)	1 ~ 20 shot/min. (0.1cm ³ /one shot)
OIL CONSUMPTION	less than dripped oil amount x0.3	
AIR CONSUMPTION	Max. 500dm ³ /min. (ANR)	
RATED VOLTAGE	<ul style="list-style-type: none"> •AC-100V 50/60Hz, AC-110V 60Hz •AC-200V 50/60Hz, AC-220V 60Hz •DC-24V 	
ELECTRICAL CONSUMPTION	30 VA (30 W)	
OIL RESERVOIR CAPACITY	1000cm ³ (Effective capacity: 800cm ³)	
MASS	9.5kg (for model "S", "F", "K", "T")	

BASIC MODEL NOS. & OTHERS

MODEL NUMBER		Additional Devices
MC5-02H2-※S01Y	MC5-02H4-※S01Y	Oil level switch and pressure switch (only basic devices)
MC5-02H2-※K01Y	MC5-02H4-※K01Y	Oil level switch, pressure switch, and plunger pump operation monitor.
MC5-02H2-※T01Y	MC5-02H4-※T01Y	Oil level switch, pressure switch, and plunger pump interval operation timer.

HOW TO ORDER

MC5 - 02H2 - 1 S 01 Y

③ ⑦ ⑧ ⑨ ⑩

CPL MICRON-LUB UNIT MC5 SERIES

③ Reservoir

02H | 1L reservoir
Oil replenishment is not possible during operation.

⑦ Lubrication Capacity

2 | Basic capacity (025) plunger pump
4 | High capacity (100) plunger pump

⑧ Rated Voltage

1 | AC-100V 50/60Hz, 110V 60Hz
2 | AC-200V 50/60Hz, 220V 60Hz
3 | DC-24V

⑨ Additional Devices

S | No additional devices (Std.)
K | Plunger pump operating monitor
T | Plunger pump intermittent operation timer

(Remarks)

*Oil level switch and pressure switch are provided on all models.

⑩ Location of pressure switch

01 | See circuit diagram I

Basic Model
MC5-02*-*-S01Y

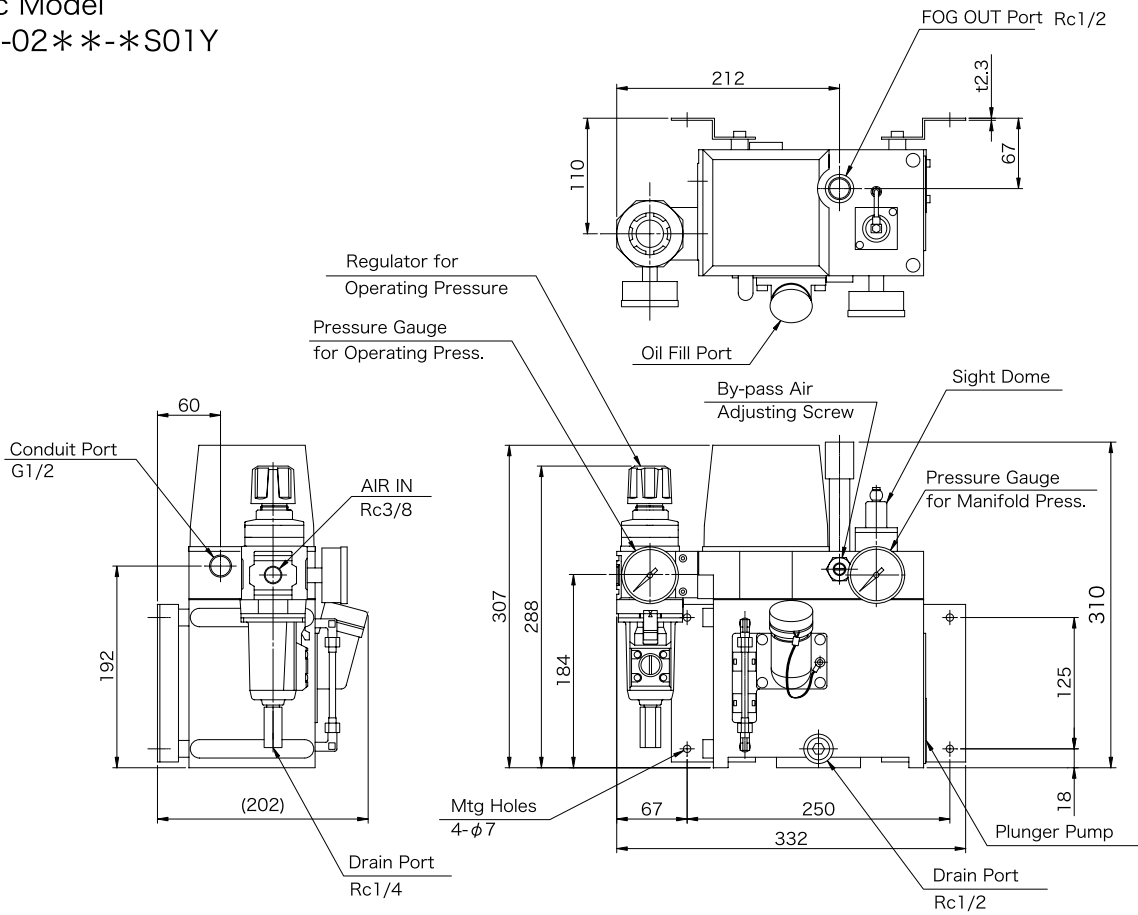

Sub-tank Model
MC5-A2L*-*-S01Y

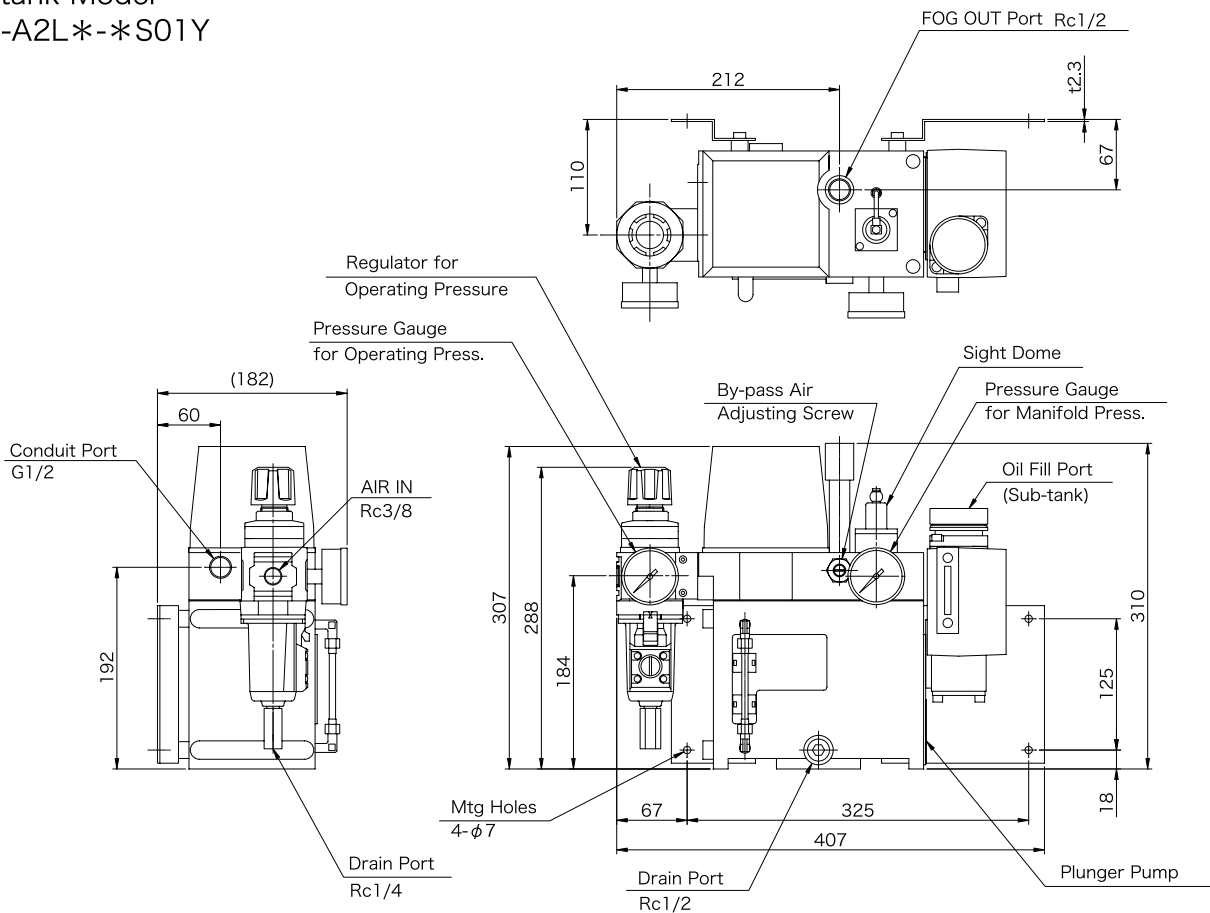

SEMI-DRY LUB

Minimum Quantity Spraying Unit L32 SERIES (Rc^{3/8})



SPECIFICATIONS

OPERATING FLUID	Compressed air filtered with 5µm element
OPERATING PRESSURE	0.2 ~ 0.5MPa
AMBIENT TEMPERATURE	5 ~ 50°C
PIPE SIZE	Rc ^{3/8}
LUBRICANT	General lubricating oil, Vegetable oil for cutting, and others
VISCOSITY	32cSt (consult us for other viscosity)
OIL SHOT RANGE	8 ~ 20 shot/min. ... Air Pulse Operated Model 1 ~ 20 shot/min. ... Electric Pulse Operated Model
OIL OUTPUT RATE OF PUMP	0.01 ~ 0.05 cc/shot (adjustable for each pump. 2 pumps are equipped on the standard unit.)
RESERVOIR	700cc (500cc: effective)
LEVEL SWITCH CAPACITY	10VA/AC, 10W/DC (for the model with level switch)
MASS OF MAIN UNIT	4.5kg (approx.)

Rated Voltage & Electrical Current of Solenoid		AC 100V 50/60Hz	AC 200V 50/60Hz	DC 24V
Air supplying solenoid valve	Inrush	0.205A	0.103A	0.380A
	Hold	0.180A	0.088A	
Pump actuating solenoid valve *1	Inrush	0.018A	0.015A	0.070A
	Hold	0.015A	0.011A	

*1 Equipped only on the L32 unit of Electric Pulse Operated model.

Basic Model No.

MODEL NUMBER	Pump Operation	Level Switch
L32-300-※M10	Solenoid valve operation (needs interval timer for electric pulse)	Nil (Std.)
L32-300-※M11		Turn ON at lower limit
L32-300-※M17		Turn OFF at lower limit
L32-300-※119		Turn OFF at lower limit, and turn ON at upper limit
L32-300-※M30	Controlled by Pulcon equipped with L32 unit	Nil(Std)
L32-300-※M31		Turn ON at lower limit
L32-300-※M37		Turn OFF at lower limit
L32-300-※139		Turn OFF at lower limit, and turn ON at upper limit

Note:

- ※ in the 7th position of the model number are for specifying the rated voltage (See HOW TO ORDER).
- Parallel tubing for outlets are optional items Use part no. 07700-|202 with length by the meter (m) required, at ordering separately.
- The nozzle assemblies are optional items. Use parts number: N11-200-B511 (Straight type) for ordering.

HOW TO ORDER

L32 - 300 -

7
8
9
10

⑦ Rated Voltage

1	AC 100V 50/60Hz
	AC 110V 60Hz
2	AC 200V 50/60Hz
	AC 220V 60Hz
3	DC 24V

⑧ Automatic Oil Filling Port

M	Nil. Manual Filling
1	With Filling Port

⑨ Pump Operation

1	Electric Pulse
3	Pulse by Pulcon

⑩ Level Switch

0	Nil
1	On at Lower limit
7	OFF at lower limit
9	ON at Upper limit
	OFF at Lower limit

DIMENSIONS —mm—

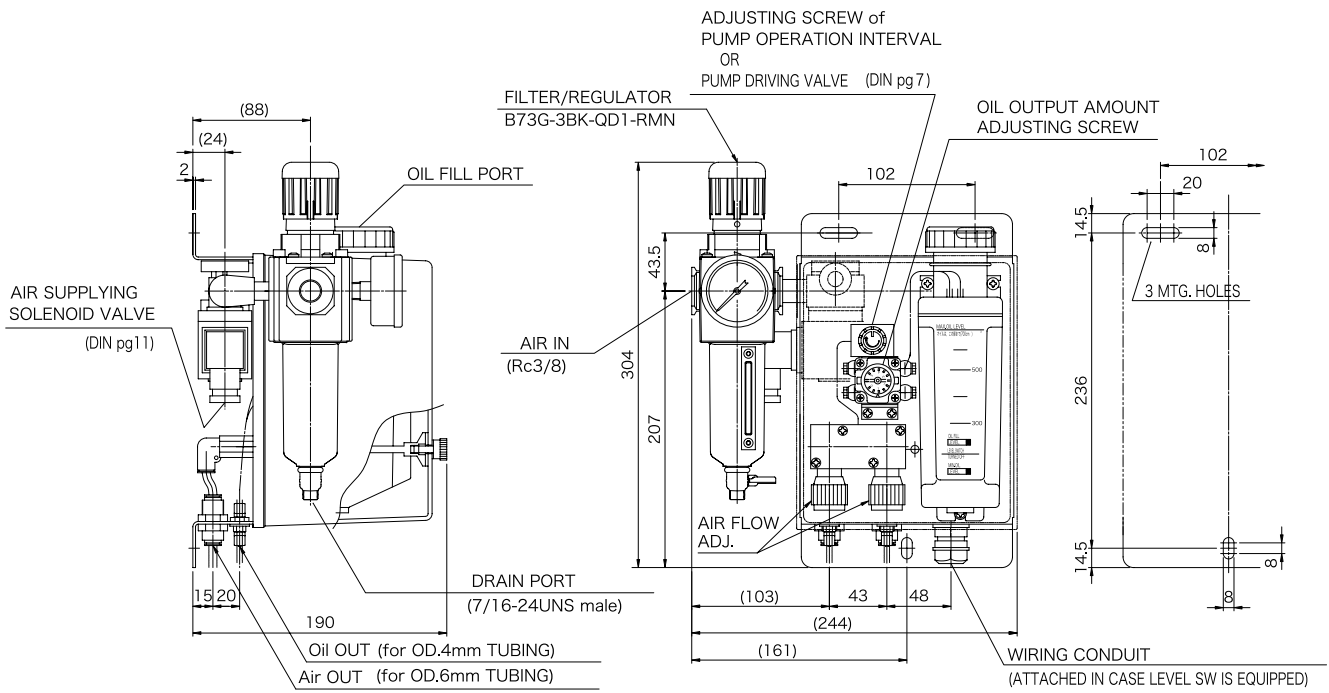

- NOZZLE — N11-200-B511
- N11-200-M511

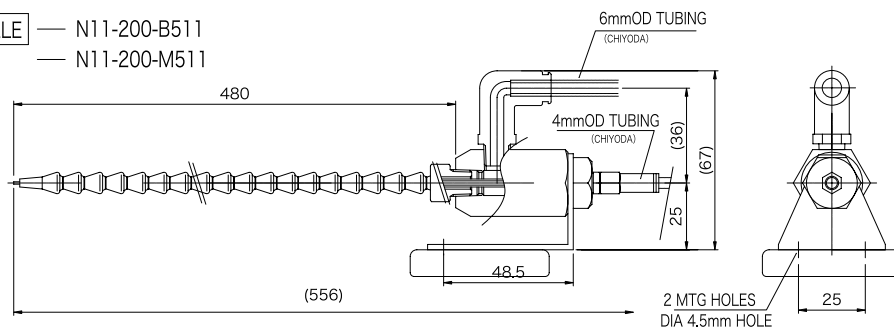

SEMI-DRY LUB

Energy Saving Oil Atomization Unit MQ4-031 SERIES



SPECIFICATIONS

Operating Fluid	*1	Purified pressure air, and contains no oil
Supply Pressure for IN Port	*2	0.2 ~ 0.8MPa
OUT Port Pressure containing Fog		Almost equal to IN port supply pressure
Withstanding Pressure		1.2MPa
Ambient Temperature		5 ~ 50°C
Viscosity of Lubricating Oil	*3	ISO VG 32 ~ 68
Setting of the Number of Shots		1 ~ 60 shots/min (quantity: 0.08cm ³ by 1shot)
Oil Reservoir Capacity		1000cm ³ (effective capacity)
Pipe Size		Air in (Supply Port) : Rc ³ / ₈ Fog Alt (Fog Output Port) : Rc ¹ / ₂
Maximum Air Flow Amount		About 500dm ³ /min
Electrical Current of Solenoid Valves		80mA max. (to PV, SV)
Protection grade structure		Equivalent to IP54
Mass		About 10kg

*1. In order to protect a Fog generation mechanism Ecomizer from the failure by supply air containing oil, attach an oil removal filter to IN port side. And install a filter of 5E element upstream to the oil removal filter to lengthen the service period of the oil removal filter.

*2. As the Fog generation mechanism Ecomizer can usually generate Fog with pressure difference of less than 0.02MPa, the pressure near IN side supply pressure is available for Fog output pressure.

*3. The oil used for MQ4 unit should select oil of viscosity which becomes under operation and within range of 10~150cSt.

Note: In order to carry out the interval action of the plunger pump for an operation of MQ4 unit, prepare a twin timer, or a programmable controller, etc. in advance. And the electrical control circuit for a semi-dry lubrication system should be formed by the user sides.

Model Numbers --- Standard type

MQ4-031-1B00... (for AC100V)

MQ4-031-3B00... (for DC24V)

Schematic Diagram of Operation

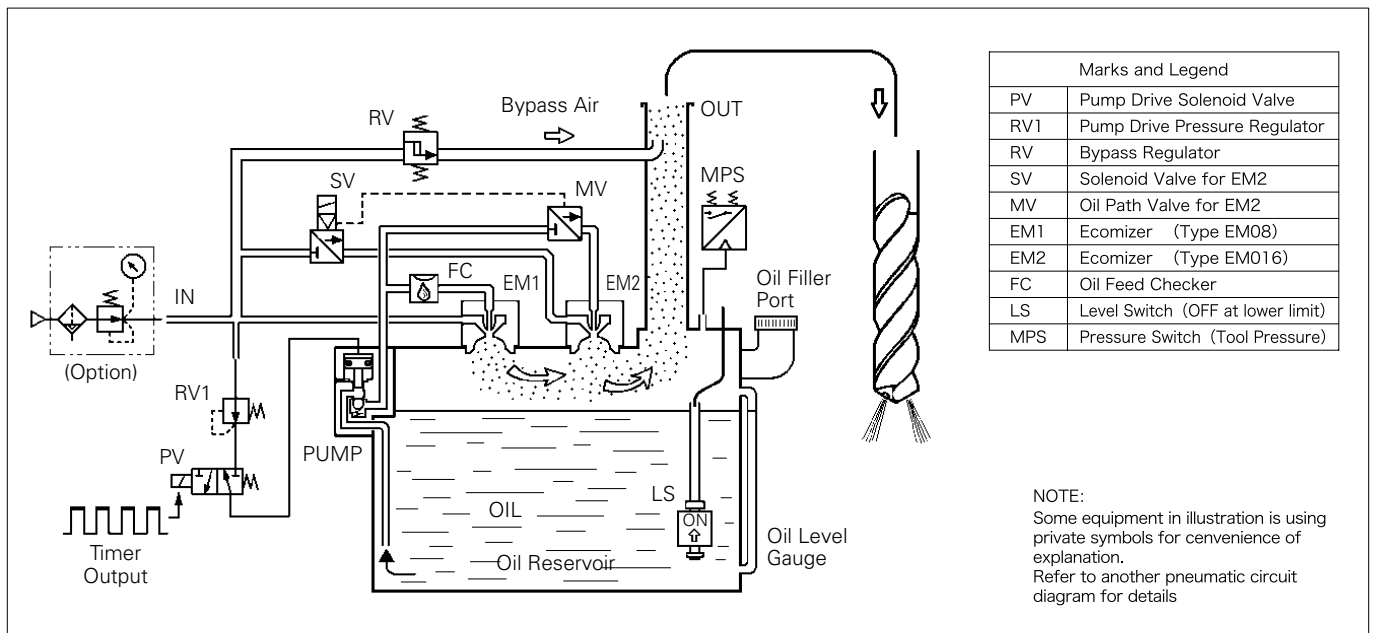

PERFORMANCE CURVE

An output oil amount by EM's circuits of generating fog in MQ4 (typical)

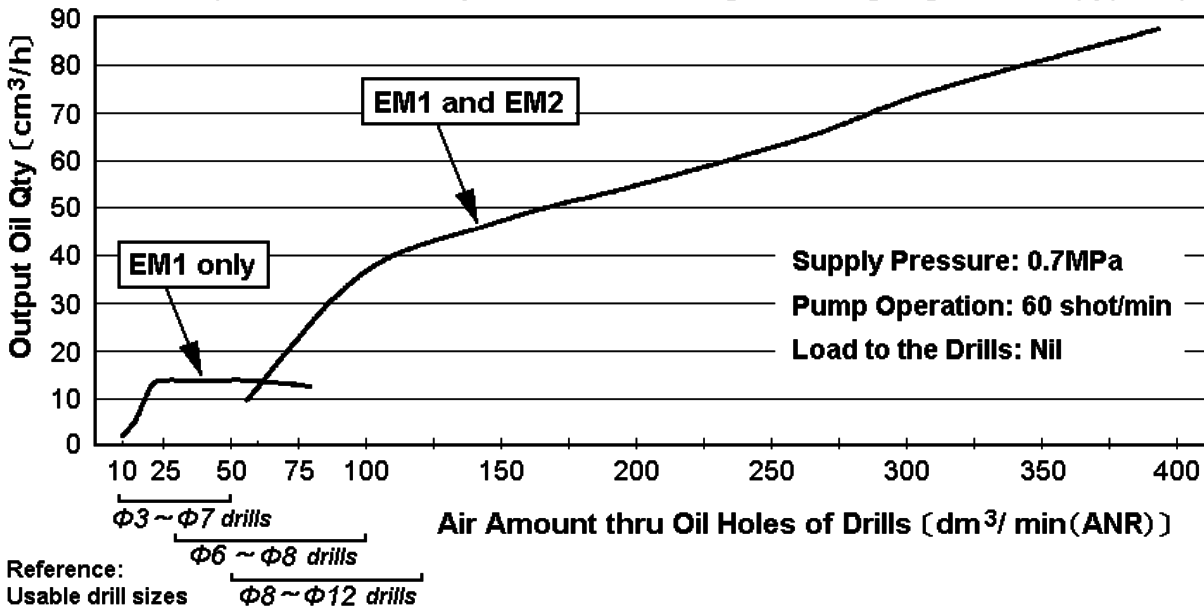

DIMENSIONS -mm-

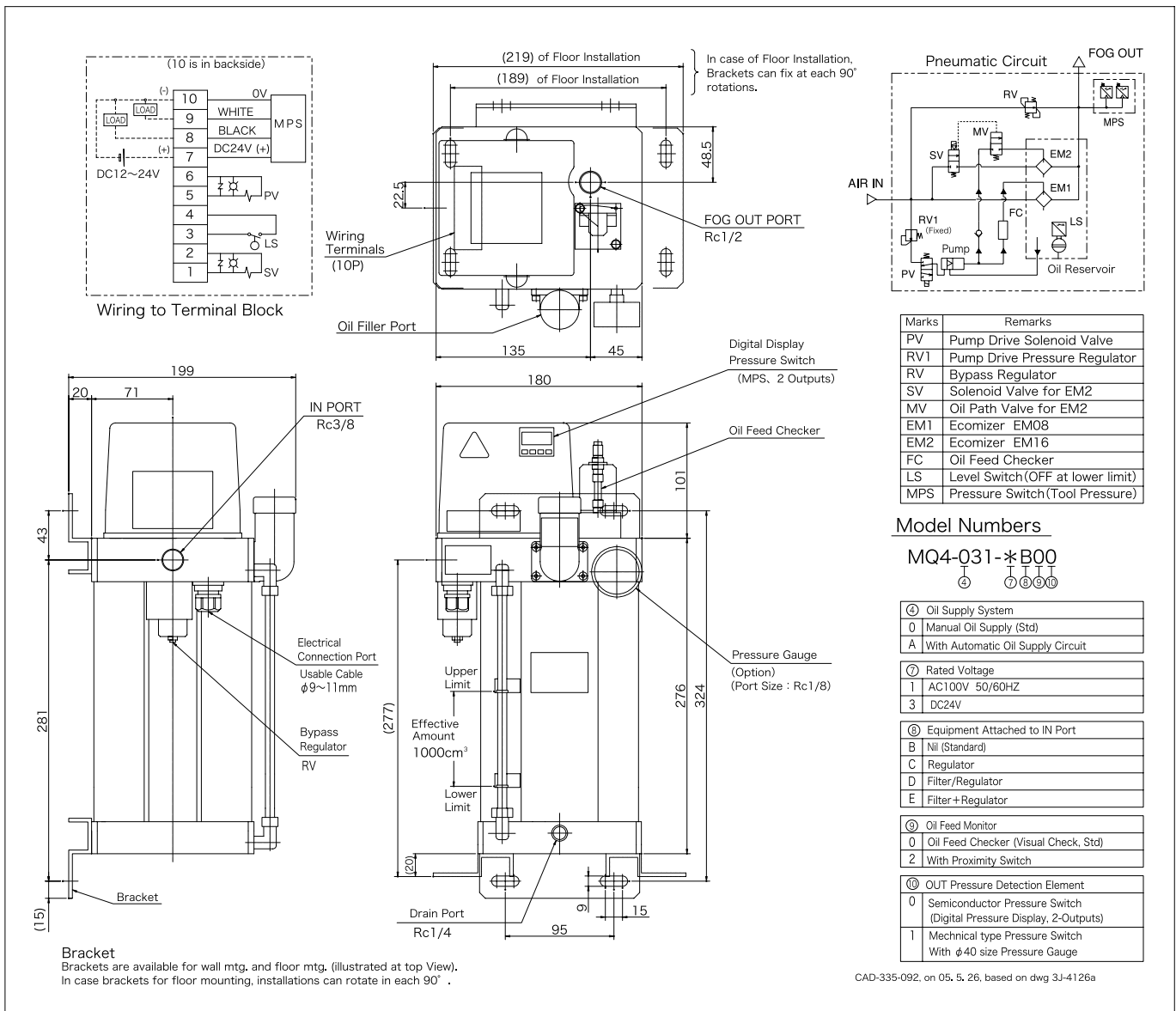

SEMI-DRY LUB

Semi-dry CPL lubrication Unit MCA Series

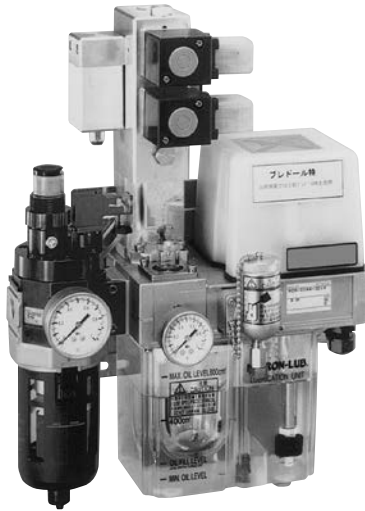

SPECIFICATIONS

Operating Fluid	
Max. Supply Pressure	1.0MPa
Operating Pressure	0.2 ~ 0.7MPa
Manifold Pressure (Output Pressure)	0.05 ~ 0.6MPa
Pipe Sizes	
Oil Viscosity	ISO VG32 ~ 68
Max. Number of Oil Shots	60 shot/min
Oil Quantity per Shot of Pump	0.05, or 0.08dm ³ , by models
Air Flow Amount	500N ℓ /min
Ambient Temperature	5 - 50°C
Rated Voltage	AC100V, DC24V
Mass	7.5kg

Model Numbers	Equipped Pump	By-pass Air Control	Other Equipments
MCA-0BB3- <i>*</i> DB4	For Fog output, and For Liquid oil output	Fixed difference pressure regulator	<ul style="list-style-type: none"> Manifold Pressure Switch, Filter/Regulator with solenoid valve (D04 type)
MCA-0BB3- <i>*</i> DB6	2 Pumps For Fog output		

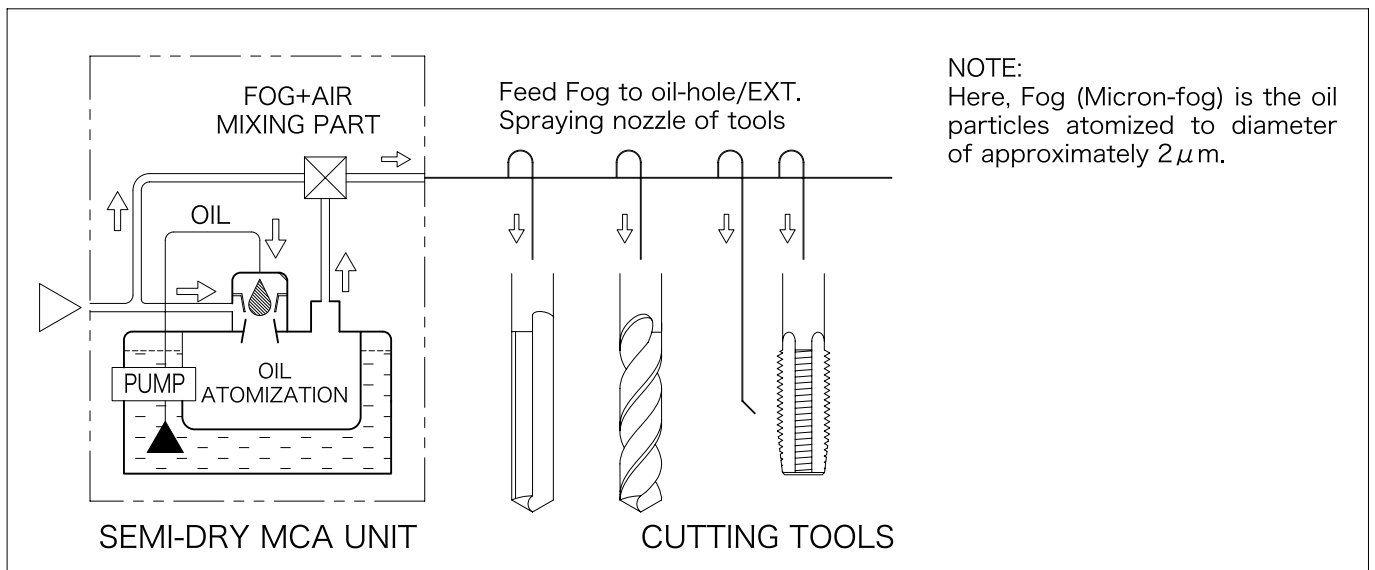

MQL machining with Semi-dry CPL lubrication unit, for cutting, grinding, drilling, tapping and etc., is processed with the very small quantity oil near almost dry state. As the machining is processed without using coolant, contaminating the working site by scattering coolant can be minimized.

Liquid wastes, which occurs by washing off the machining oil on the works and scraps, are also minimized.

Features

- Minimum and optimum supply of the fine cutting oil particles prevents the environmental pollution by scattering of the oil, or by undesirable oil drip.
- By the newest machining system, the working site can always secure clean environment.
- Drastic saving of time that would be required for the liquid removal from the work and scraps, and reduction of accompanying cost would be performed.
- The disposal cost of waste liquid and waste oil could be minimized.
- It is desirable equipment for zero emission machining.
- It is useful for long life of tool, for improvement of machining efficiency, and for reduction of the running costs.
- Better and high accuracy finishing surface is acquired by lubrication effect of oil fog particles and cooling effect of air.

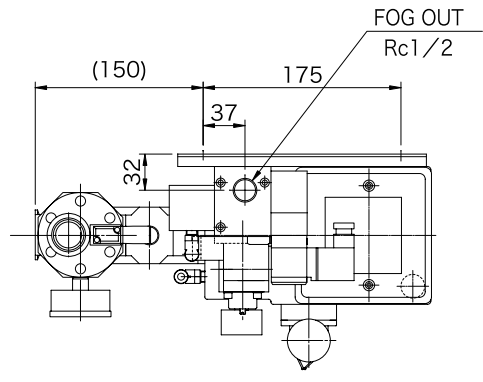

MCA-0BB3-*DB6

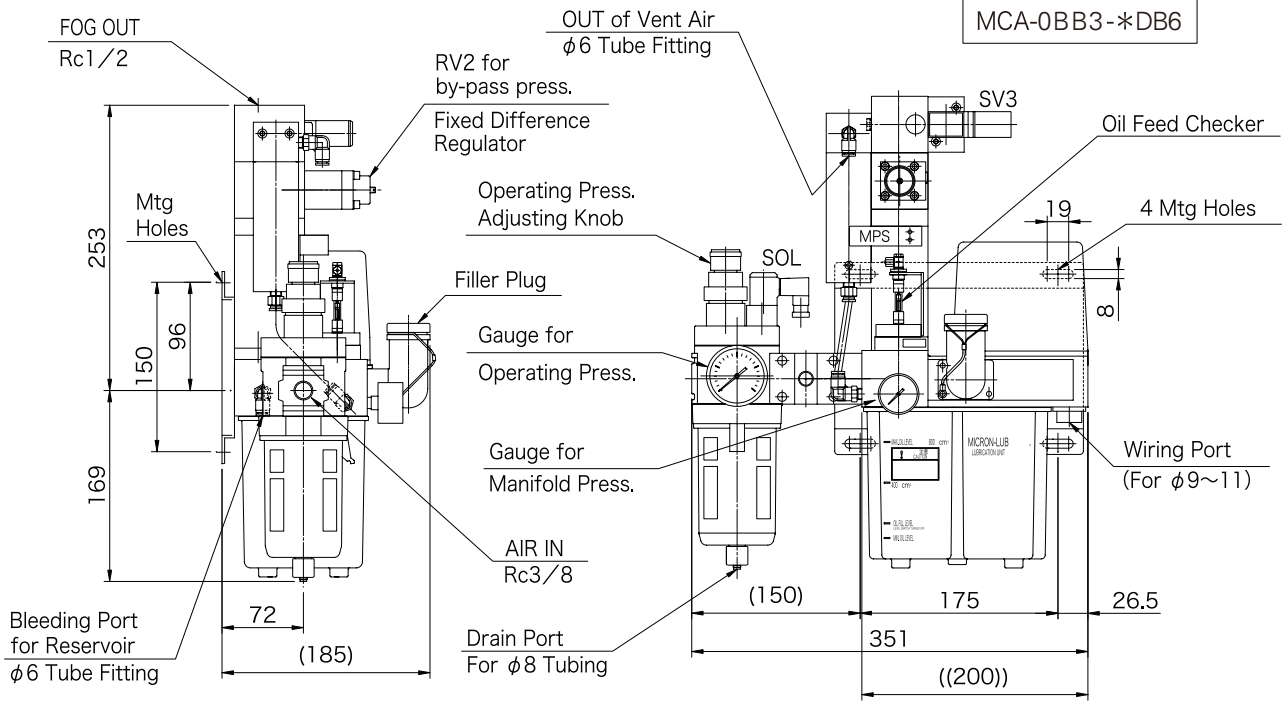

MCA-0BB3-*DA6

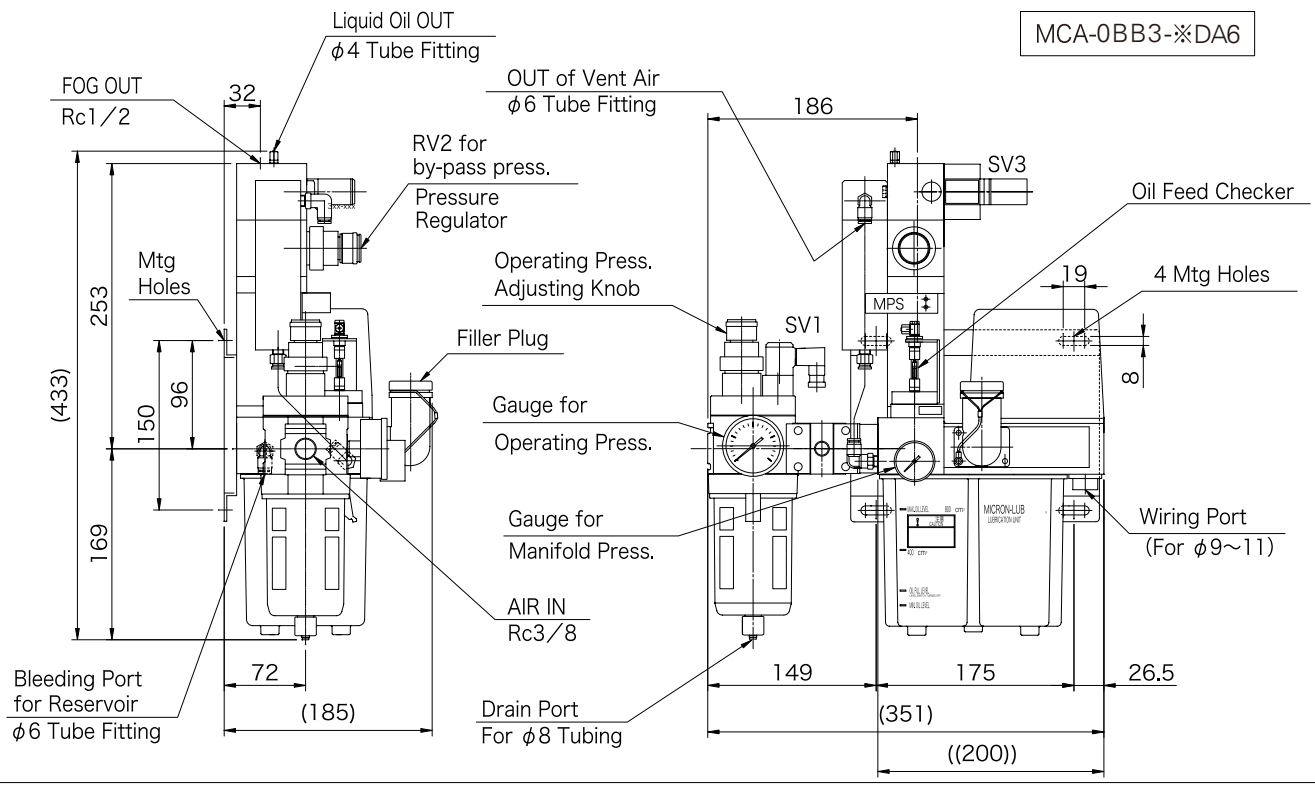

(By 3J-4128, H-8598B)

HYBRID LUBRICATION UNIT

OIL MIST LUBRICATION AND FORCED LUBRICATION MCB SERIES



SPECIFICATIONS

LUBRICATION SYSTEM	Hybrid lubrication (1) CPL Micron-lub lubrication (2) Intermittent constant oil lubrication
OIL TANK CAPACITY	6,000cm ³ (Nominal), 4,300cm ³ (Effective) Low oil level switch equipped
RECOMMENDED OIL	ISO VG32 ~ 68 with suitability for mist lubrication
AMBIENT TEMPERATURE	5 ~ 40°C
RATED VOLTAGE	AC-100V
MASS	16kg

EACH SPECIFICATIONS

CPL Micron Lubrication		Intermittent Constant Oil Lubrication	
Fluid	Clean compressed air*	Pump Type	Gear pump
Operating Pressure	0.15 ~ 0.35MPa	Oil Output	90cm ³ /Min. (50Hz)
Manifold Pressure	0.03 ~ 0.25MPa	Output Pressure	1.5MPa. Max.
Endurance Pressure	0.5MPa	Motor	Intermittent
Air Consumption	500dm ³ /Min. (ANR)	Oil Output Port	M10X1
Oil Amount / Shot	0.05cc	Elect. Consumption	0.2A (Motor)
Available Nos. of Shot	1 ~ 20 Shots/Min.		
Pipe Size	Air Supply Rc ³ / ₈ Fog Out Rc ¹ / ₂		
Elect. Consumption	70mA (Pump)		

* : Filtered with under 5 micron element and dried air.

HOW TO ORDER

MODEL NUMBER	Filter / Regulator with 2-Way Solenoid Valve	Micron-Lub Side Manifold Pres. Switch
MCB-B6L3-1D0A	Equipped	Not Equipped
MCB-B6L3-1D0B	Equipped	Equipped

The above models are equipped followings as standard option:

Oil level switch, pressure gauge for operating pressure, pressure gauge for manifold pressure, pressure gauge for oil output.

Pressure switch for oil pressure (P/NO: 92570) is on option.

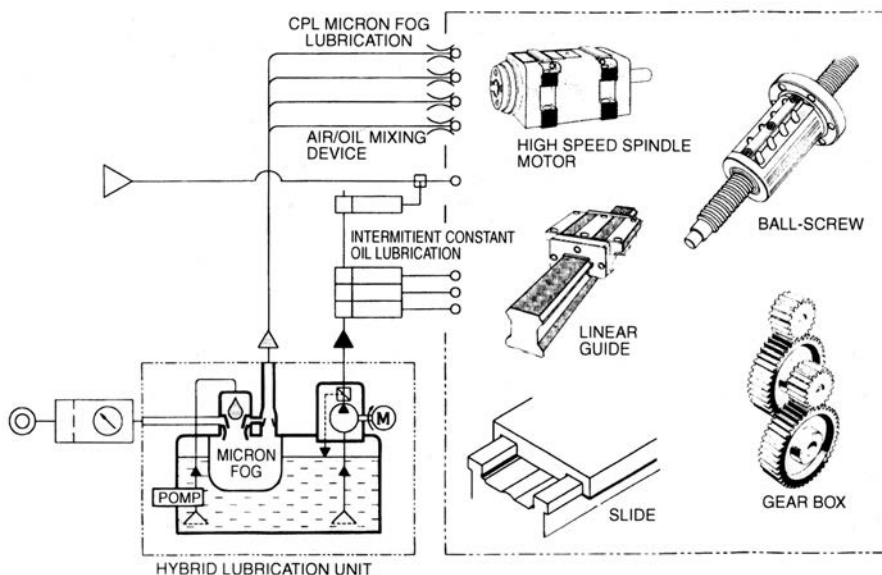

HYBRID LUBRICATION UNIT:

(ILLUSTRATION SHOWS COMMON RESERVOIR TYPE. 2 RESERVOIRS TYPE FOR CPL MICRON LUB LUBRICATION AND INTERMITTANT CONSTANT OIL LUBRICATION ARE AVAILABLE)

DIMENSIONS —mm—

Wiring of Terminal Block

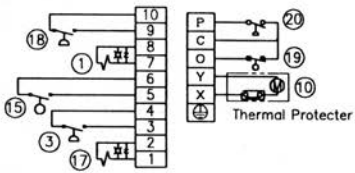

Micron-lub (ML) Section Oil Pump Unit (OP) Section

No	Parts
1	3-Port Valve for Pump
3	Pressure Switch for ML
10	Pump Driving Motor
15	Oil Level Switch for ML
17	Pilot Valve of D04 Unit
18	Manifold Pressure Sw for ML
19	Oil Level Switch for OP
20	Pressure Switch for OP

DWG-335-078

Air-In port of the models without D04 unit is on line marked ∇
 Drawing is for a double reservoir type.
 Single reservoir type equips with 1 oil gauge.

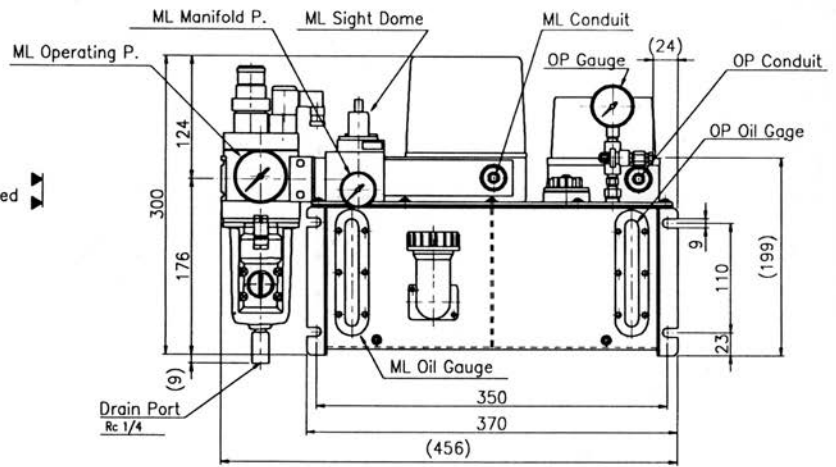
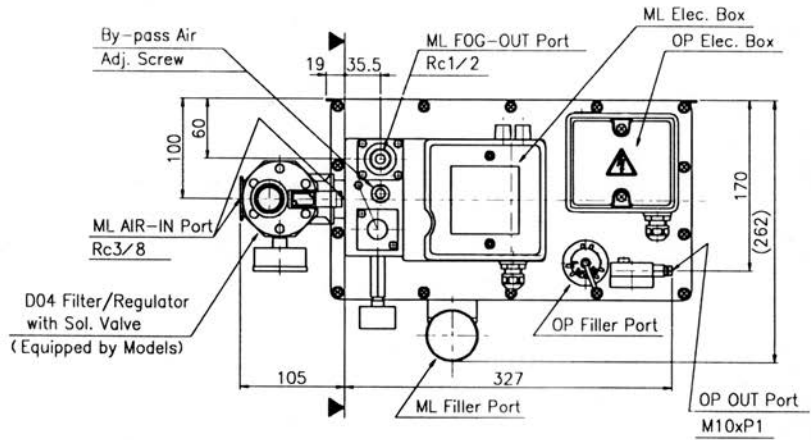

MEMO

A series of horizontal dotted lines for writing.

Please read the "Terms and Conditions" from the following URL before ordering or use.

<http://atc.azbil.com/products/bi/order.html>

[NOTE]

Specifications of the products are subject to change without notice. No part of this publication may be reproduced or duplicated without the prior written permission of Azbil TA Co., Ltd.

Azbil TA Co., Ltd.

AZBIL TA - Fluid Control Technology at Its Best.

※TACO CO., LTD. changed its name to Azbil TA Co., Ltd. on April 1, 2013.

Main Office address and Engineering Service network.

9-27-9 Takashimadaira, Itabashi-ku, Tokyo, JAPAN 175-0082

Tokyo Engineering Service	: TEL 03-3936-2311
Tohoku Engineering Service	: TEL 0244-36-8962
Kita-Kanto Engineering Service	: TEL 048-556-9511
Ebina Engineering Service	: TEL 046-233-6741
Nagoya Engineering Service	: TEL 052-322-1631
Osaka-Shiga Engineering Service	: TEL 077-553-0611
Hiroshima Engineering Service	: TEL 082-875-4041
Kyushu Engineering Service	: TEL 093-651-4955
Shanghai Contact Office (China)	: TEL +86-18964051952

Please ordering to the following agency or to our engineering service.

Azbil TA Co., Ltd. <http://atc.azbil.com/>

Catalogue:SP-054d(1000,Adpal)
Sept.1998.1st Edition
May 2013:Revision SP-054d