

Blow Type Application Examples

● Removal of static charges when taking out or storing wafers

Avoids electrostatic discharging when taking wafers out of their cassettes, and prevents the stored wafers from being attracted to the transfer arm.

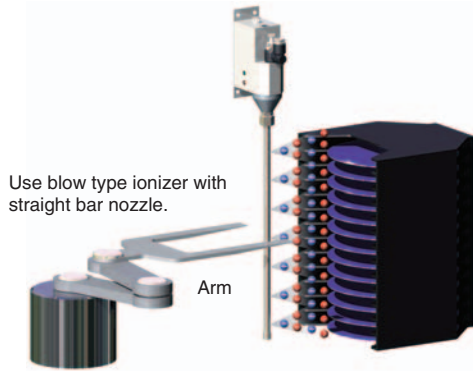

● Removal of static charges when conveying wafers

Prevents dust from being attracted to the surface of wafers. Prevents the internal patterns from being damaged.

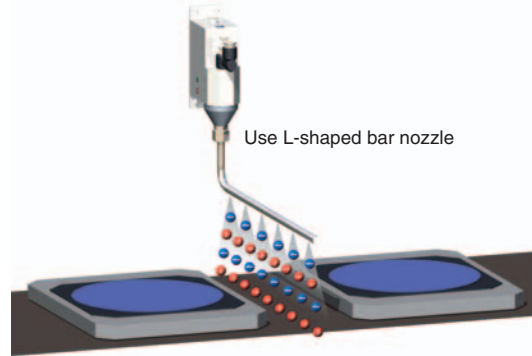

● Removal of static charges on parts when carried by a parts feeder

Static electricity is generated due to friction of parts while the parts feeder conveys them, and the parts stick to feeder's surface. Use the blow type ionizer to prevent parts from being stuck caused by static electricity. Also, simultaneous use with a fan type is effective against the static electricity removal.

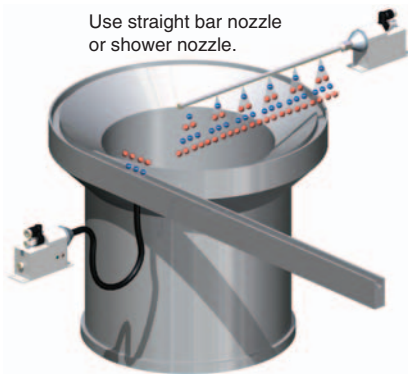

● Removal of static charges on wafers

Use blow type ionizers with shower nozzles that provides ionized air flow with a wide angle to remove static charges on wafers.

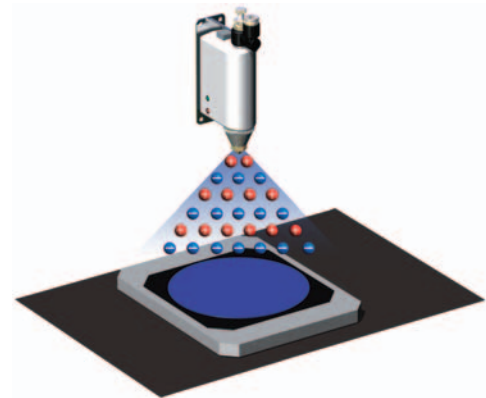

● Removal of static charges and particles on CDs and DVDs

Use 2-head types with bender nozzles to remove static charges and particles on CDs and DVDs from both sides.

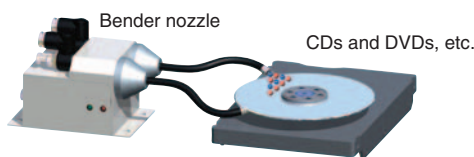

● Removal of static charges on wrap film

Use blow type Ionizers with U-shaped bar nozzles in confined space to remove static charges on both sides of the wrap film.

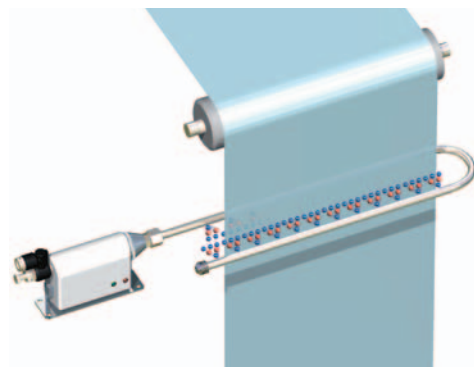

● **Removal of static charges on devices carried by pallets**

Use blow type Ionizers with straight bar nozzles to remove static charges on a wide carrying pallet.

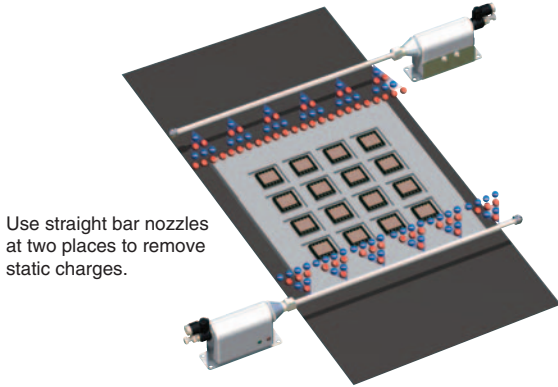

● **Removal of static charges in printing process**

Use 2-head type Ionizers with bender nozzles. Prevents faulty printing caused by static charges in ink jet printing process.

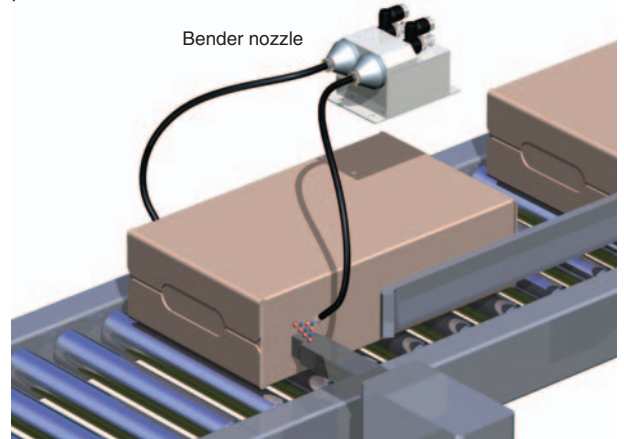

● **Removal of static charges in bottles (Removal of dust)**

Use a spiral bar nozzle to remove static charges inside a bottle.

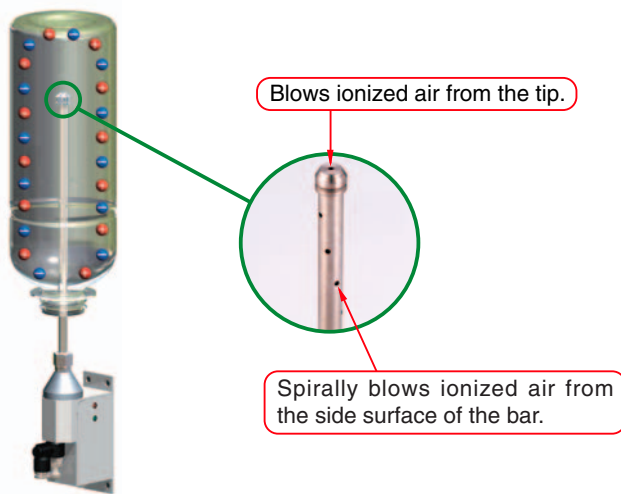

● **Removal of static charges on electronic parts**

Very low generation of electrical noise

- No damage to a device caused by induction electric field by the discharging needle.
 - Removal of static charges with pin point accuracy (It is possible to place the nozzle close to a device by using the tube.)
- Note: Select a tube in accordance with the degree of tube flexibility.

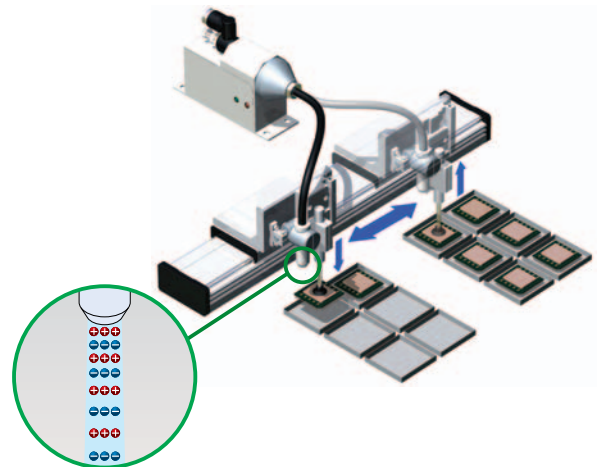

● **Removal of static charges on glass substrate**

Use 2-head type Ionizers with two straight bar nozzles to remove static charges on FPD glass.

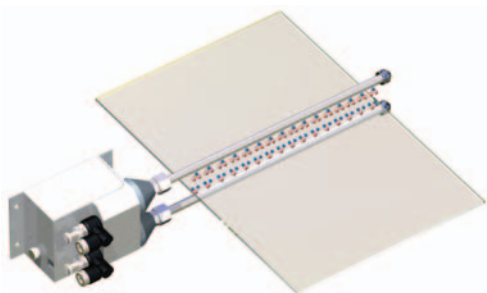

● **Removal of static charges in pipes (φ50 or less)**

By inserting the tube inside a pipe enables removal of static charges.



Select the nozzle for your application

● Shower nozzle

- Blows ionized air at 60° or 90° angles

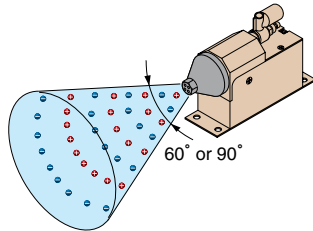

● Flat nozzle

- Blows ionized air at 90° angle, suitable for removal of static charges over relatively wide area.

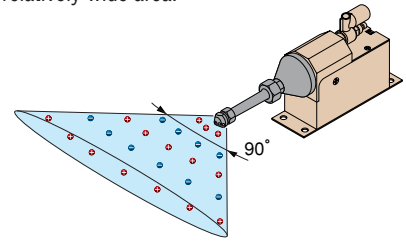

● Straight bar nozzle

- Removal of static charges over a wide area.
- 5 types of bar nozzles are applicable for 100 to 500 mm ionized air coverage.

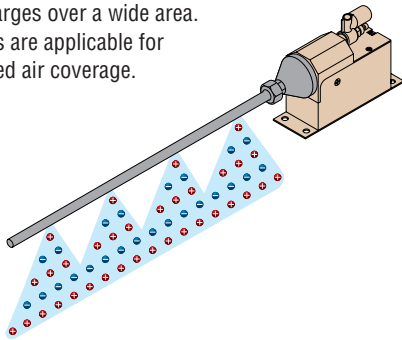

● Use of two straight bar nozzles

- Removal of static charges from both sides of film simultaneously.

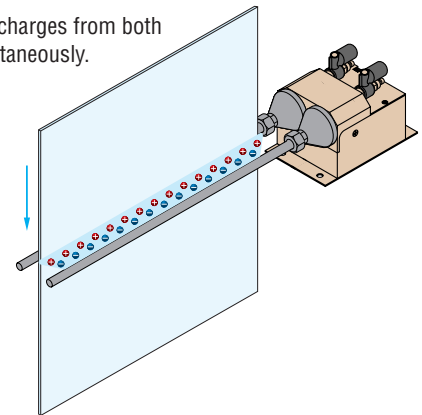

● L-shaped bar nozzle

- Space saving and suitable for locations where straight bar nozzles can't reach.
- 2 types of L-shaped bar nozzles are applicable for 100 and 200 mm ionized air coverage.

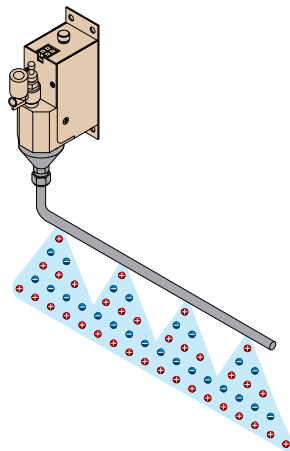

● U-shaped bar nozzle

- Removal of static charges from both sides simultaneously up to 100 mm wide film.

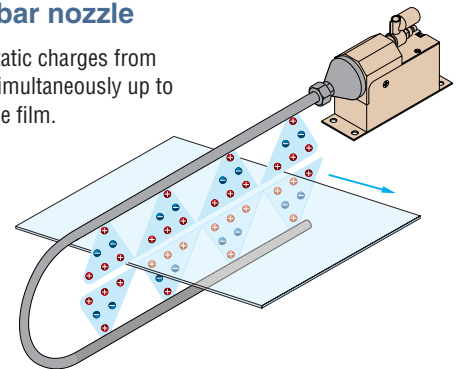

● Free-mounting L-shaped bar nozzle

- Enables the bar rotation to change the direction of the ionized air flow outlet.
- It is applicable for 100 and 200 mm ionized air coverage.

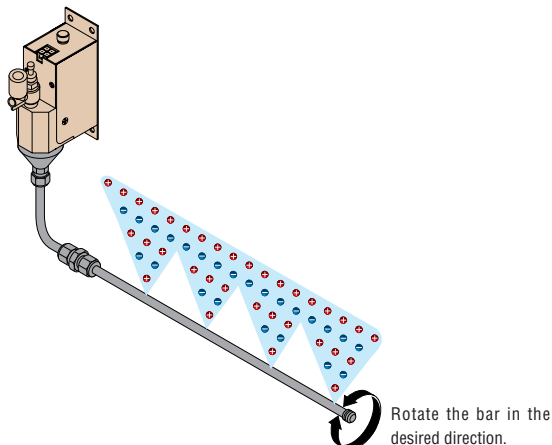

● Combining various nozzle units with bender nozzles

- Combining various nozzle units with the flexible tube enables static charge removal for various applications.

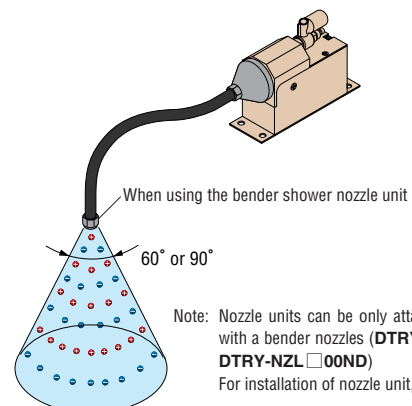

Note: Nozzle units can be only attached to the nozzles with a bender nozzles (DTRY-NZR□00ND and DTRY-NZL□00ND)
For installation of nozzle unit, see page 29.

Specifications

BLOW TYPE

Blow Type and Compact Blow Type

Model		DTRY-ELB01 (Main Unit for 1-head Type)	DTRY-ELB02 (Main Unit for 2-head Type)	DTRY-ELL01 (Main Unit for 1-head Type)
Power supply		24 VDC ± 5%		
Consumption current	mA	Approx. 100		
Output voltage	kV	Approx. 2 (High frequency type)		
Indicator LED	Power supply	While power is supplied, power indicator LED (Green) turns on.		
	Abnormality	When an abnormal discharge occurs, the abnormality indicator LED (Red) turns on.		
Power safety circuit		The contact point output NO/NC is selectable when an abnormal discharge occurs. ^{Note 1} (24 DVC 50 mA Max.)		The contact point output NO/NC is selectable when an abnormal discharge occurs. ^{Note 1} (24 DVC 50 mA Max.)
Outer dimensions	mm	92(L)×30(W)×54(H) (Main unit only)	92(L)×62(W)×54(H) (Main unit only)	65(L)×25(W)×47(H) (Main unit only)
Mass	g[oz.]	190 [6.70] (Main unit only)	300 [10.58] (Main unit only)	122 [4.30] (Main unit only)
Ion balance ^{Note 2}	V	±15		
Ozone generation amount	ppm	0.037 or less (When measured at 300 mm apart from the nozzle outlet with a standard nozzle and 0.25 MPa air at primary side.)		
Media ^{Note 3}		Air (vapor- and oil-removed clean air)		
Supply air flow rate	ℓ/min(ANR)	Approx. 100 (with DTRY-NZR01NS nozzle and 0.15 MPa air at primary side, per head.)		Approx. 50 (with DTRY-NZL01NS nozzle and 0.1 MPa air at primary side)
Operating air pressure range	MPa[psi.]	0.02 ~ 0.25 [3 ~ 36] (with DTRY-NZR01NS nozzle) 0.02 ~ 0.12 [3 ~ 17] (with DTRY-NZR02S nozzle) 0.02 ~ 0.12 [3 ~ 17] (with conductive urethane, Teflon or silicone tube) 0.05 ~ 0.25 [7 ~ 36] (with DTRY-NZR100ND ~ 500ND nozzles) 0.05 ~ 0.40 [7 ~ 58] (with DTRY-NZR20SW nozzle) 0.05 ~ 0.40 [7 ~ 58] (with DTRY-NZR21SW nozzle) 0.05 ~ 0.40 [7 ~ 58] (with DTRY-NZR01FT nozzle) 0.05 ~ 0.40 [7 ~ 58] (with DTRY-NZR200SP nozzle) 0.05 ~ 0.40 [7 ~ 58] (with DTRY-NZR100B ~ 500B nozzles) 0.05 ~ 0.40 [7 ~ 58] (with DTRY-NZR100L ~ 200L nozzles) 0.05 ~ 0.40 [7 ~ 58] (with DTRY-NZR100U nozzle) 0.05 ~ 0.40 [7 ~ 58] (with DTRY-NZR100FMT ~ 200FMT nozzles)		0.05 ~ 0.5 [7 ~ 73]
Operating ambient temperature	°C[°F]	0 ~ 40 [32 ~ 104] indoor (avoid a place subject to dew condensation)		
Accessories		1 pc. power and signal cable (2 m), 1 pc. ground wire (2 m), and 1 pc. contact point selector protection sticker		1 pc. power and signal cable (2 m), 1 pc. bracket, and 1 pc. contact point selector protection sticker

Notes 1: For output of abnormality output contact point, see page 23.

2: The ion balance value of the DTRY-ELL01 is the value when the air flow rate is 150 ℓ/min(ANR).

3: Always turn on the power supply with supplying air.

Remarks 1: When using two or more ionizers, mount them at least 10 mm apart. Closer mounting may cause a detrimental effect or detrimental ion balance.

2: Ion balance is measured by in-house test standard. Consult us for details.

Graphs of Static Charge Removing Characteristics

(when using the standard nozzle) ※ See pages 23~28 for Graphs of Static Charge Removing Characteristics when using the other nozzles.

Blow Type DTRY-ELB01

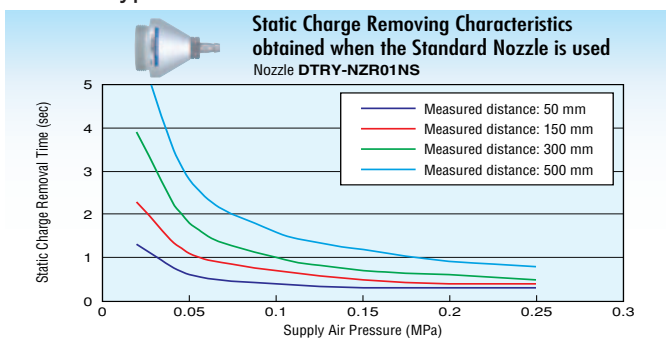

Compact Blow Type DTRY-ELL01

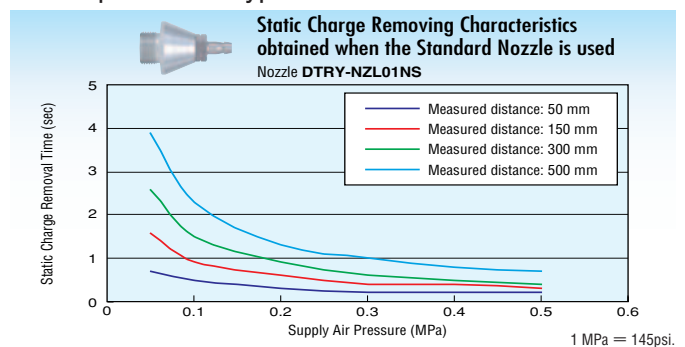

Controller

Model		DTRY-ELC11
Power supply		24 VDC ± 5%
Consumption current	mA	410
Outer dimensions	mm	222 (L) × 60 (W) × 135 (H) (Main unit only)
Mass	g[oz.]	830 [29.28] (Main unit only)
Media		Air
Max. flow rate	ℓ/min(ANR)	150 (0.7 MPa at primary-side pressure and 0.5 MPa at secondary-side pressure)
Operating pressure adjusting range	MPa[psi.]	0.02 ~ 0.5 [3 ~ 73]
Proof pressure	MPa[psi.]	1.5 [218]
Filter capacity	Filtering particle diameter μm	0.01
	Filtering efficiency %	99.99
Operating ambient temperature	°C[°F]	5 ~ 45 [41 ~ 113] indoor (avoid a place subject to dew condensation)
Accessories		1 pc. connection cable between controller and ionizer (1.5 m)

Note: Pay attention to the maximum flow rate and operating pressure adjusting range when using the controller. It may cause a shortage of the flow rate compared to the one obtained not using the controller.

Remark: The ionizer is a stand-alone unit. However, the use with the controller enables control of both power supply and air.

Order code

BLOW TYPE

Main Unit

- 1-head type
DTRY-ELB01



- 2-head type
DTRY-ELB02



Caution The main unit cannot be operated alone. Always use it with a nozzle.

Caution The discharging needles are covered with cover caps for protection. Remove the cap before installing the nozzle.

Nozzles for Blow Type

- Standard nozzle
DTRY-NZR01NS



- Flat nozzle
DTRY-NZR01FT



- Free-mounting L-shaped bar nozzles
DTRY-NZR100FMT
(Nominal size: 100 mm)
DTRY-NZR200FMT
(Nominal size: 200 mm)



- Bender nozzles
DTRY-NZR100ND (100 mm)
DTRY-NZR200ND (200 mm)
DTRY-NZR300ND (300 mm)
DTRY-NZR400ND (400 mm)
DTRY-NZR500ND (500 mm)



- Straight bar nozzles
DTRY-NZR100B (Nominal size: 100 mm)
DTRY-NZR200B (Nominal size: 200 mm)
DTRY-NZR300B (Nominal size: 300 mm)
DTRY-NZR400B (Nominal size: 400 mm)
DTRY-NZR500B (Nominal size: 500 mm)



- U-shaped bar nozzle
DTRY-NZR100U



- Stainless steel pipe nozzle (120 mm)
DTRY-NZR02S



- L-shaped bar nozzles
DTRY-NZR100L (Nominal size: 100 mm)
DTRY-NZR200L (Nominal size: 200 mm)



- Shower nozzles
DTRY-NZR20SW (60° type)
DTRY-NZR21SW (90° type)



- Spiral bar nozzle
DTRY-NZR200SP



Option

- Bracket
(For straight bar nozzle)
DTRY-ELQ02



Caution: Dedicated for the blow type

Common Options for Blow Type and Compact Blow Type

- Bender shower nozzle units
DTRY-ADN-SW60 (60° type)
DTRY-ADN-SW90 (90° type)



- Bender flat nozzle unit
DTRY-ADN-FT01



- Bender bar nozzle units
DTRY-ADN-100B (Nominal size: 100 mm)
DTRY-ADN-200B (Nominal size: 200 mm)



- Conductive urethane tube (500 mm)
DTRY-ADN-U



Outer diameter: $\phi 6$
Inner diameter: $\phi 4$

- Teflon tube (500 mm)
DTRY-ADN-F



Outer diameter: $\phi 7$
Inner diameter: $\phi 5$

- Silicone tube (500 mm)
DTRY-ADN-S



Outer diameter: $\phi 7$
Inner diameter: $\phi 4$

Note 1: The tube is a consumable item; periodic replacement is required.

: The **DTRY-ADN-S** and **DTRY-ADN-F** cannot be used for the earlier type standard nozzles **DTRY-NZR01S** and **DTRY-NZL01S**.

Remarks 1: Use Teflon tube for endurance-oriented, and silicon tube for flexibility-oriented.

2: 20 m or 100 m roll of conductive urethane tubes is available.

Order code: **U6A-B** (20 m)

U6A-B-100 (100 m)

COMPACT BLOW TYPE

Main Unit

- 1-head type
DTRY-ELL01



Caution The main unit cannot be operated alone. Always use it with a nozzle.

Caution The discharging needle is covered with the cover cap for protection. Remove the cap before installing the nozzle.

Nozzles for Compact Blow Type

- Standard nozzle
DTRY-NZL01NS



- Bender nozzles
DTRY-NZL100ND (100 mm)
DTRY-NZL200ND (200 mm)
DTRY-NZL300ND (300 mm)
DTRY-NZL400ND (400 mm)
DTRY-NZL500ND (500 mm)



- Stainless steel pipe nozzle (120 mm)
DTRY-NZL02S



- Shower nozzles
DTRY-NZL20SW (60° type)
DTRY-NZL21SW (90° type)

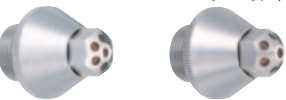

- Flat nozzle
DTRY-NZL01FT

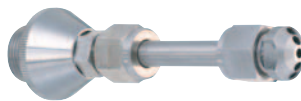

- Straight bar nozzles
DTRY-NZL100B (Nominal size: 100 mm)
DTRY-NZL200B (Nominal size: 200 mm)
DTRY-NZL300B (Nominal size: 300 mm)
DTRY-NZL400B (Nominal size: 400 mm)
DTRY-NZL500B (Nominal size: 500 mm)



- L-shaped bar nozzle
DTRY-NZL100L (Nominal size: 100 mm)



- Free-mounting L-shaped bar nozzles
DTRY-NZL100FMT (Nominal size: 100 mm)
DTRY-NZL200FMT (Nominal size: 200 mm)



- U-shaped bar nozzle
DTRY-NZL100U



- Spiral bar nozzle
DTRY-NZL200SP



Caution Dedicated use for DTRY-ELL01. These nozzles cannot be used for DTRY-LCE.

- Conductive urethane tube holder
DTRY-NZR31

For application examples, refer to page 8
Caution: Dedicated use for conductive urethane tube



- AC adapter
DTRY-ELC04

Rating
Input : 100 VAC to 240 VAC
50/60 Hz, 0.6A
Output: 24 VDC, 750mA



- Controller
DTRY-ELC11



- Tungsten discharging needle for replacement (supplied by a set of 5 needles)
DTRY-ELB11

Caution Dedicated for DTRY-ELL01, DTRY-ELB01 & 02.

- Dedicated tool for replacing the discharging needle
Note: Bit alone is available.
DTRY-ELB21

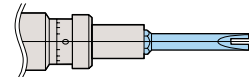

Shape of the bit inserting section

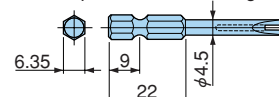

BLOW TYPE Dimensions (mm)

BLOW TYPE

Main Unit

● 1-head type DTRY-ELB01

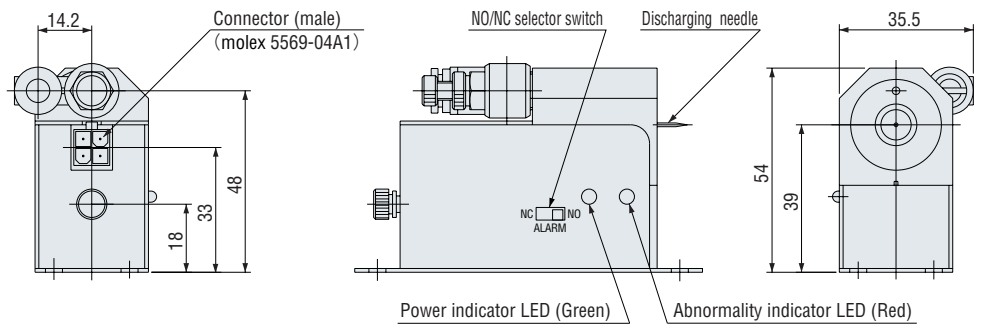
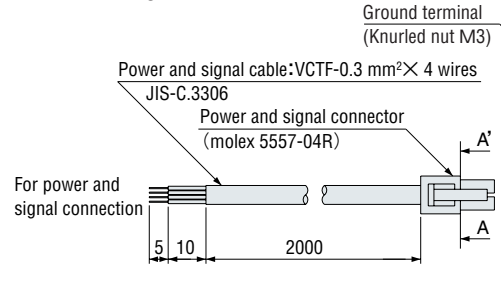
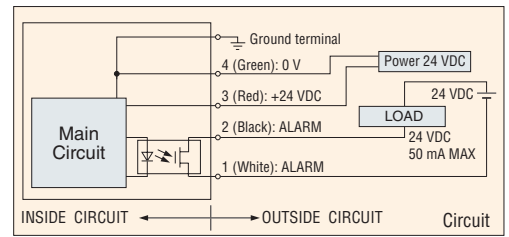
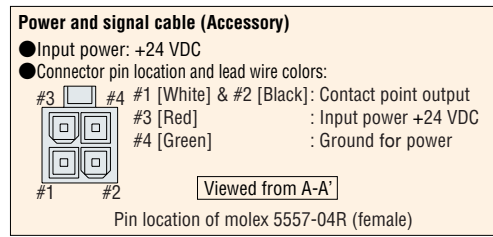

● 2-head type DTRY-ELB02

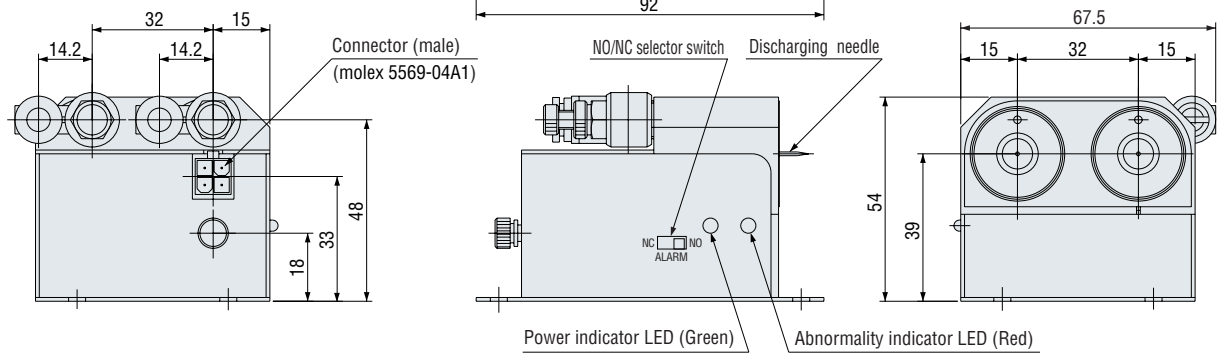
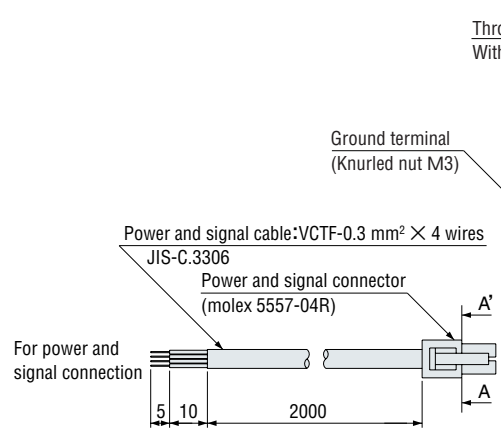
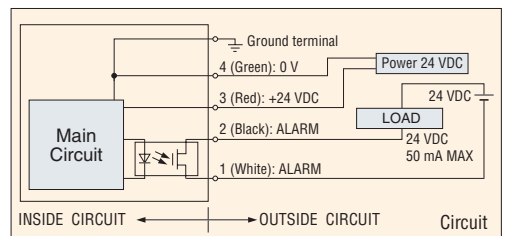
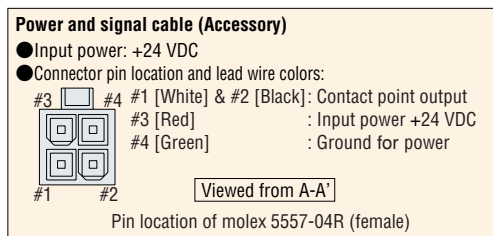

BLOW TYPE

Nozzles

● **Standard nozzle DTRY-NZR01NS**

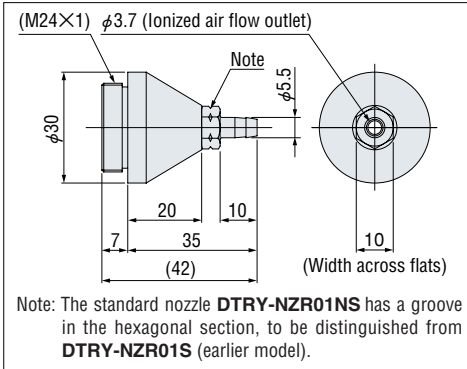

● **Stainless steel pipe nozzle DTRY-NZR02S**

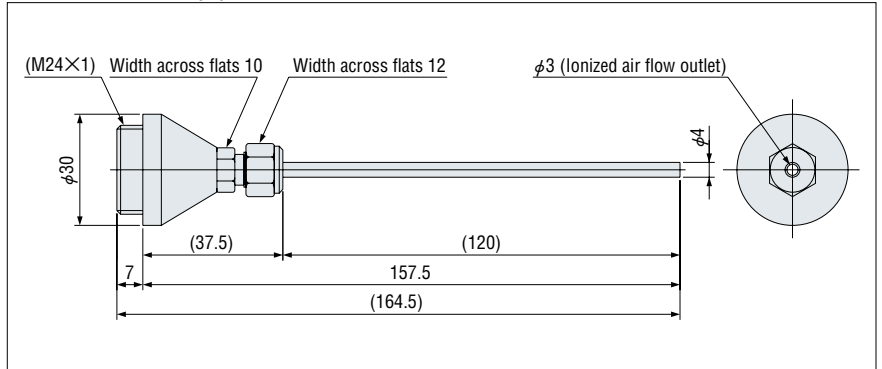

● **Shower nozzle (60° type) DTRY-NZR20SW**

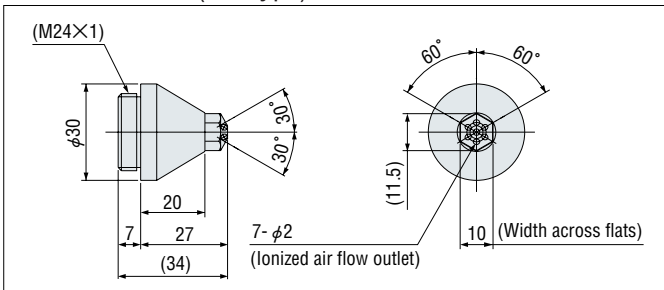

● **Shower nozzle (90° type) DTRY-NZR21SW**

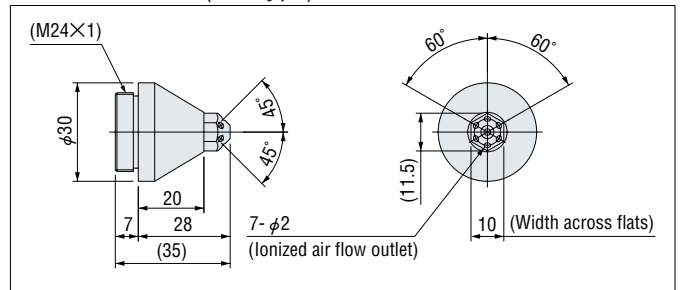

● **Flat nozzle DTRY-NZR01FT**

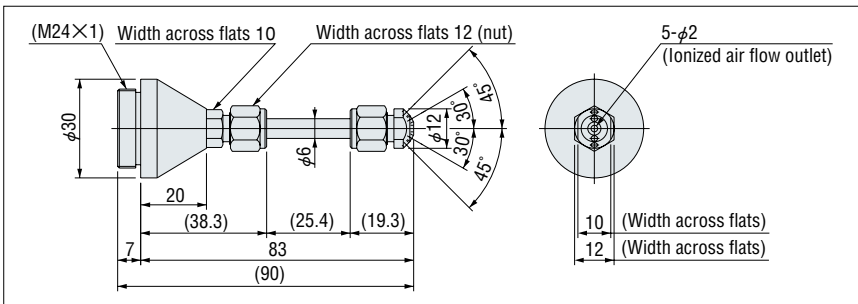

● **Straight bar nozzle DTRY-NZR□00B**

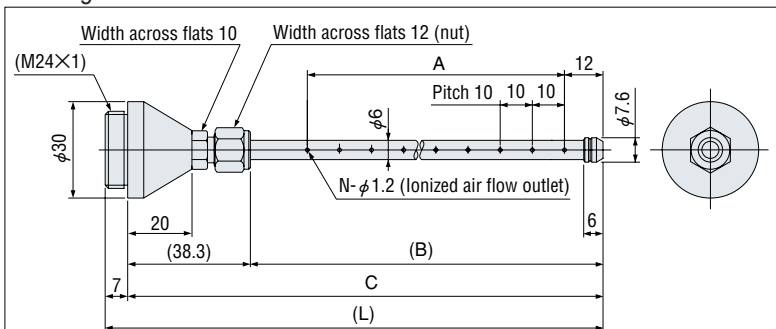

Model	A	B	C	L	N
DTRY-NZR100B	100	129.7	168	175	11
DTRY-NZR200B	200	229.7	268	275	21
DTRY-NZR300B	300	329.7	368	375	31
DTRY-NZR400B	400	429.7	468	475	41
DTRY-NZR500B	500	529.7	568	575	51

■ **Bracket for straight bar nozzle DTRY-ELQ02**

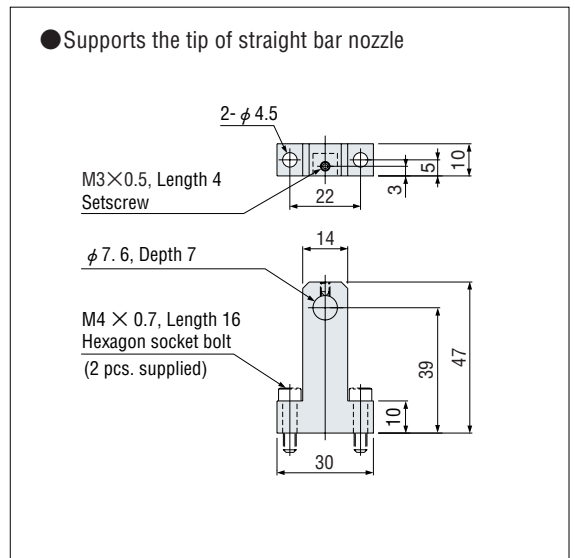

Remark: Loosen the nut to adjust the direction of the ionized air flow outlet.
 Note: Do not contact the nozzle with a grounded conductive object.
 The abnormality indicator LED may turn on.

BLOW TYPE

■ Nozzles

● Spiral bar nozzle DTRY-NZR200SP

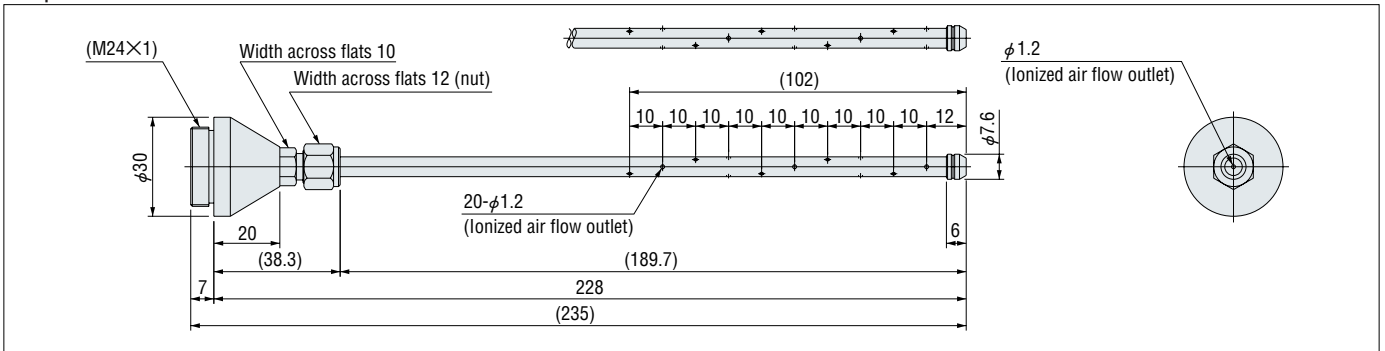

● U-shaped bar nozzle DTRY-NZR100U

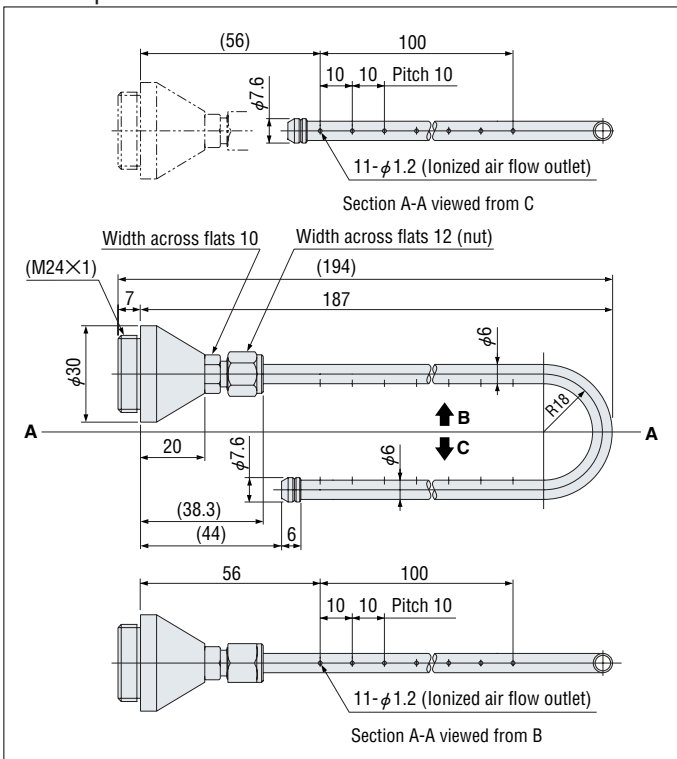

● L-shaped bar nozzle DTRY-NZR□00L

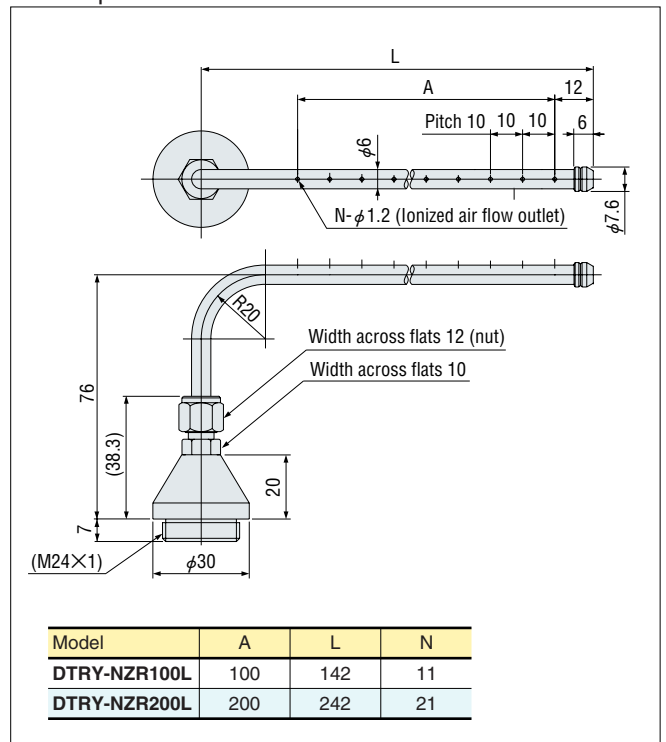

● Free-mounting L-shaped bar nozzle DTRY-NZR□00FMT

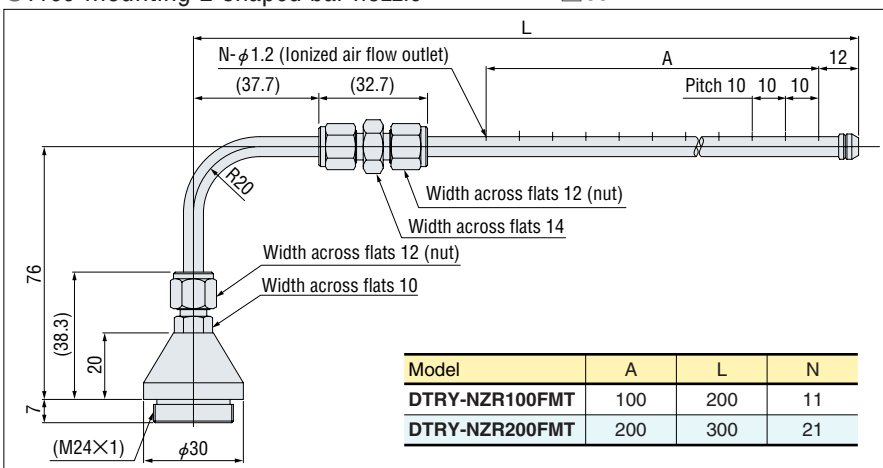

Remark: Loosen the nut to adjust the direction of the ionized air flow outlet.
 Note: Do not contact the nozzle with a grounded conductive object.
 The abnormality indicator LED may turn on.

BLOW TYPE

Nozzles

● Bender nozzle **DTRY-NZR□00ND**

Model	A	L
DTRY-NZR100ND	102	129
DTRY-NZR200ND	202	229
DTRY-NZR300ND	302	329
DTRY-NZR400ND	402	429
DTRY-NZR500ND	502	529

■ Optional nozzle units for bender nozzles. (use the unit at the tip of a flexible tube for changing a nozzle)

● Bender shower nozzle unit (60° type) **DTRY-ADN-SW60**

● Bender shower nozzle unit (90° type) **DTRY-ADN-SW90**

● Bender flat nozzle unit **DTRY-ADN-FT01**

● Bender bar nozzle unit **DTRY-ADN-□00B**

Model	A	B	L	N
DTRY-ADN-100B	100	129.7	158	11
DTRY-ADN-200B	200	229.7	258	21

Remark: Loosen the nut to adjust the direction of the ionized air flow outlet.
 Note: Do not contact the nozzle with a grounded conductive object.
 The abnormality indicator LED may turn on.

BLOW TYPE

COMPACT BLOW TYPE Dimensions (mm)

COMPACT BLOW TYPE

Main Unit

● 1-head type DTRY-ELL01

Power and signal cable (Accessory)

- Input power: +24 VDC
- Connector pin location and lead wire colors:
 - #1 [White] & #2 [Black]: Contact point output
 - #3 [Red]: Input power +24 VDC
 - #4 [Green]: Ground for power

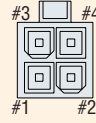

Viewed from A-A'

Pin location of molex 5557-04R (female)

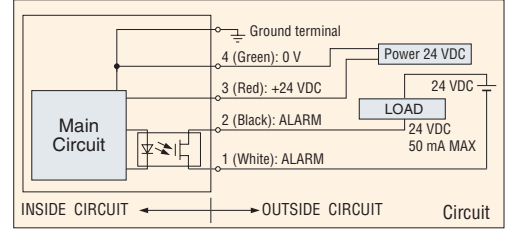

- Notes 1: ON/OFF of the power to the Ionizer should be done at the input side (+24 VDC side).
 2: Ground for power and ground terminal are connected inside.
 3: For output of abnormality output contact point, see page 29.

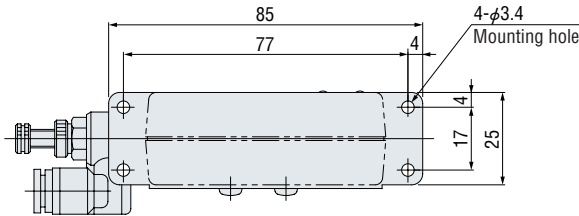
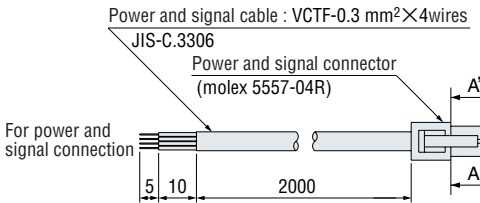
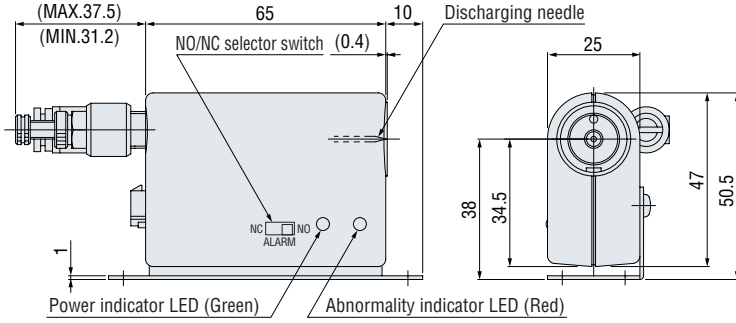
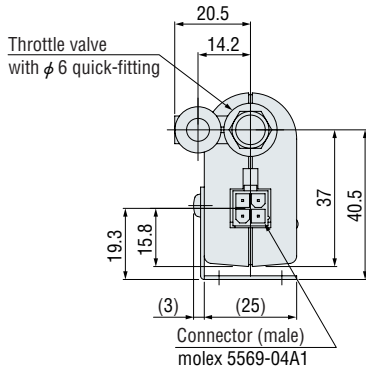

M3×0.5, Depth 7 (Ground terminal)
 Dual use as a tapped hole for mounting the main unit

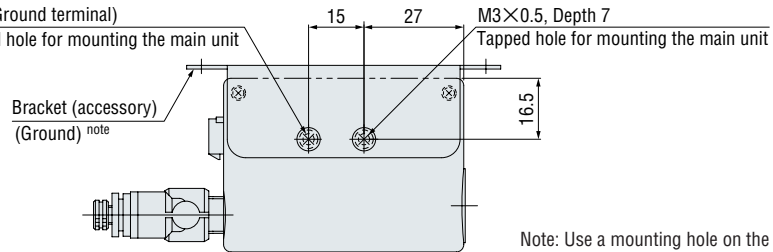

Note: Use a mounting hole on the bracket for grounding.

COMPACT BLOW TYPE

Nozzles

● Standard nozzle DTRY-NZL01NS

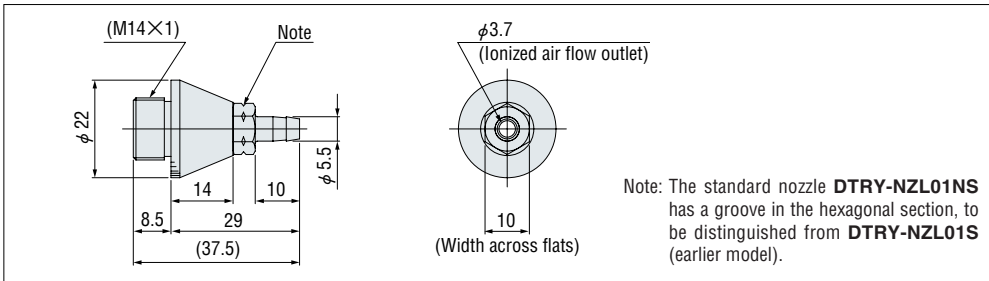

● Shower nozzle (60° type) DTRY-NZL20SW

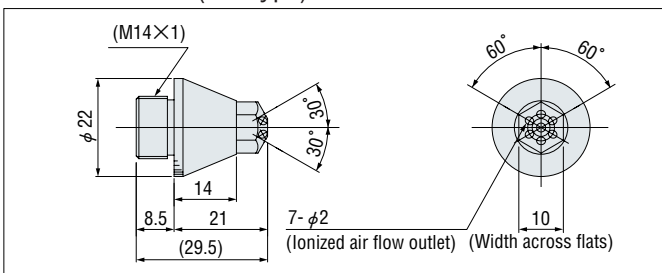

● Shower nozzle (90° type) DTRY-NZL21SW

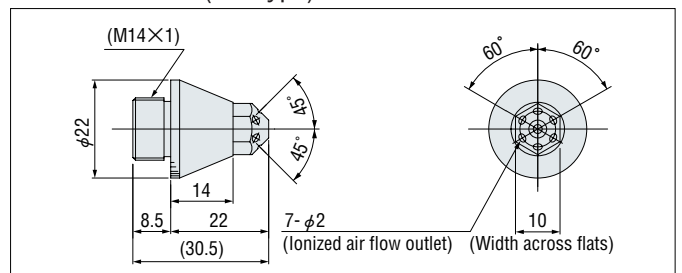

COMPACT BLOW TYPE

Nozzles

● Flat nozzle **DTRY-NZL01FT**

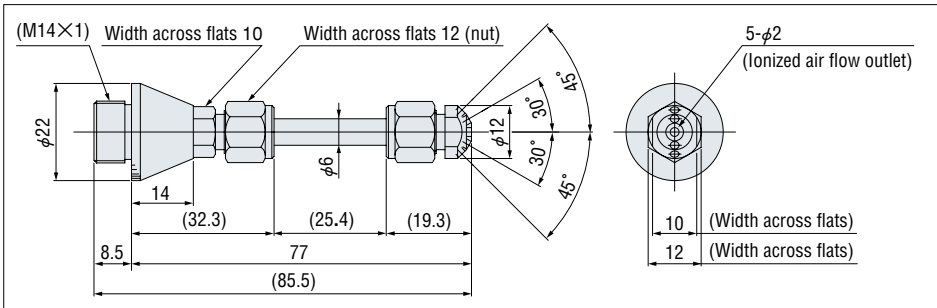

● Stainless steel pipe nozzle **DTRY-NZL02S**

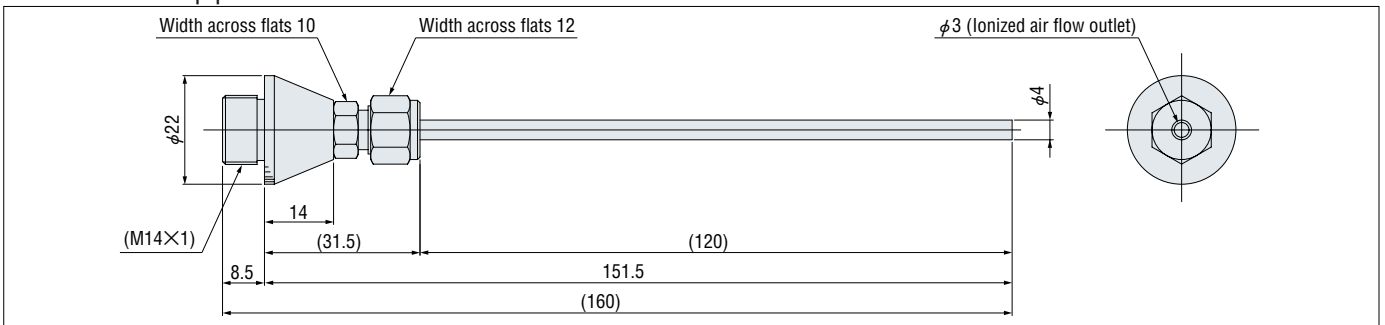

● Straight bar nozzle **DTRY-NZL□00B**

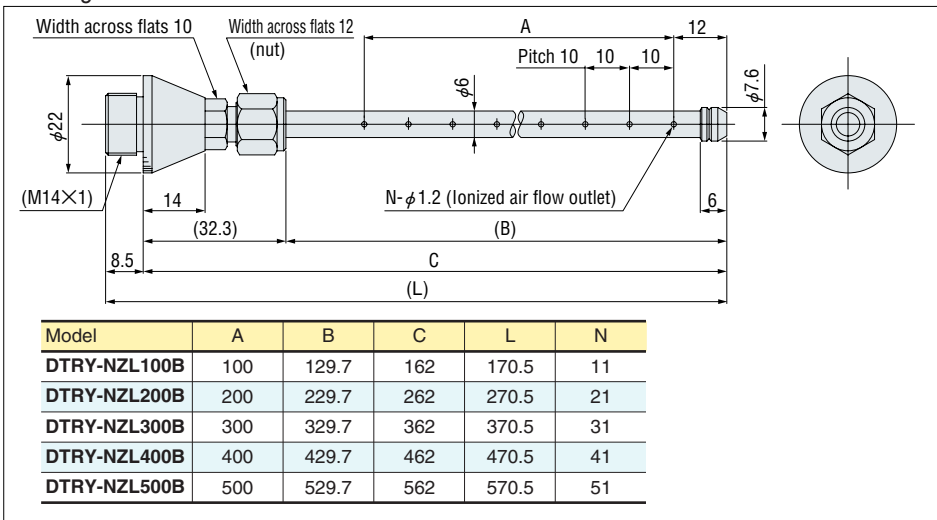

● Spiral bar nozzle **DTRY-NZL200SP**

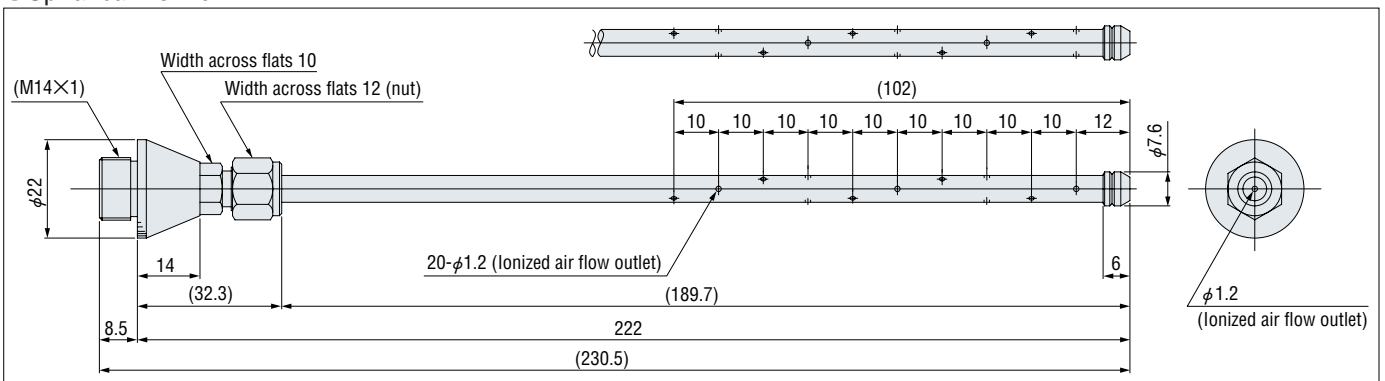

Remark: Loosen the nut to adjust the direction of the ionized air flow outlet.
 Note: Do not contact the nozzle with a grounded conductive object.
 The abnormality indicator LED may turn on.

COMPACT BLOW TYPE

Nozzles

● U-shaped bar nozzle DTRY-NZL100U

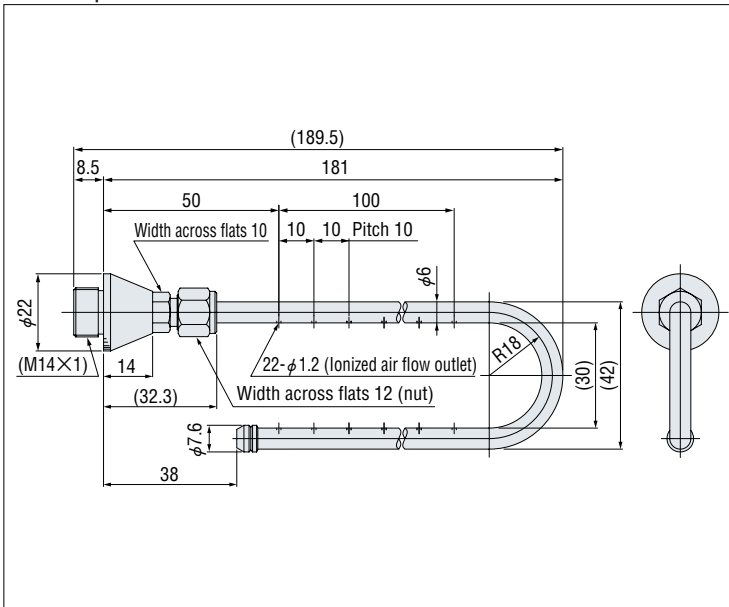

● L-shaped bar nozzle DTRY-NZL100L

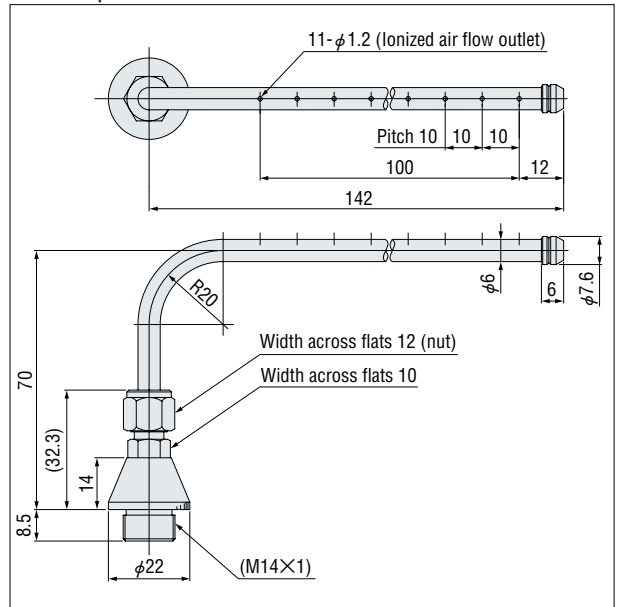

● Free-mounting L-shaped bar nozzle DTRY-NZL□00FMT

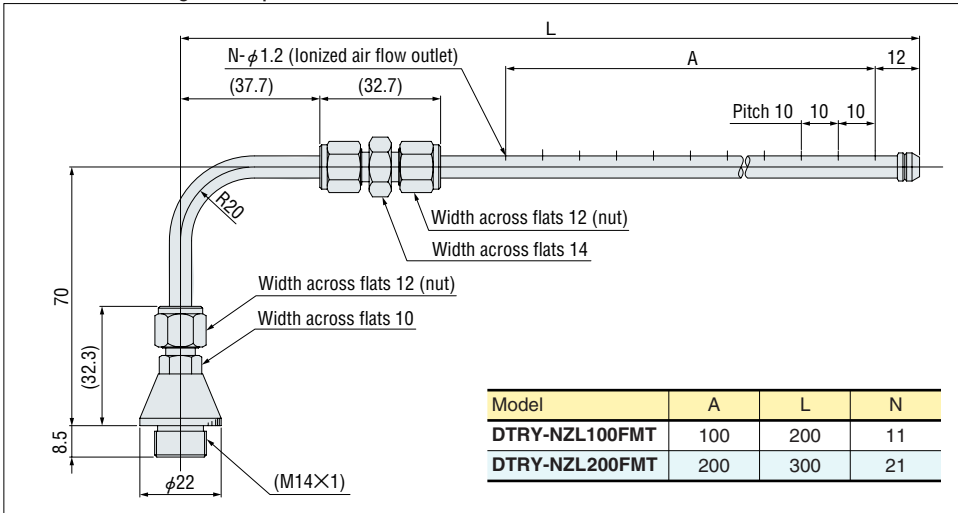

● Bender nozzle DTRY-NZL□00ND

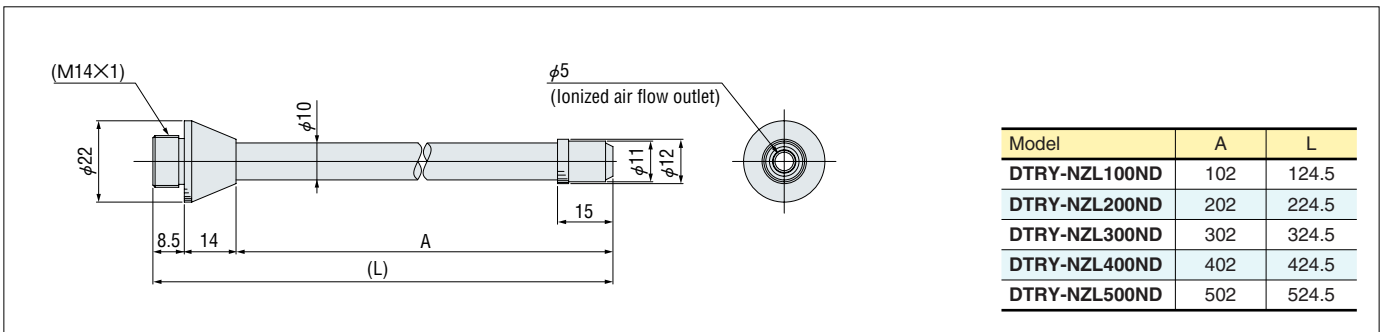

Remark: Loosen the nut to adjust the direction of the ionized air flow outlet.
 Note: Do not contact the nozzle with a grounded conductive object.
 The abnormality indicator LED may turn on.

COMPACT BLOW TYPE

■ Optional nozzle units for bender nozzle (use the unit at the tip of a flexible tube for changing a nozzle)

BLOW TYPE

● Bender shower nozzle unit (60° type) **DTRY-ADN-SW60**

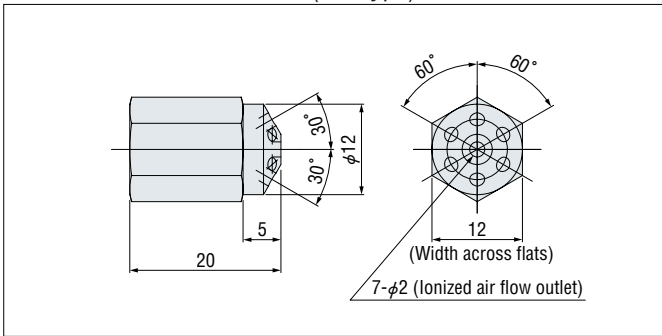

● Bender shower nozzle unit (90° type) **DTRY-ADN-SW90**

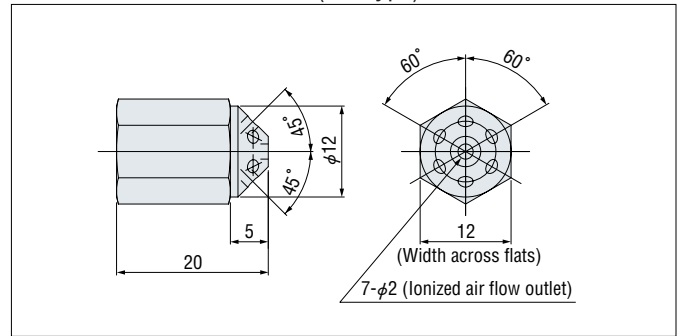

● Bender flat nozzle unit **DTRY-ADN-FT01**

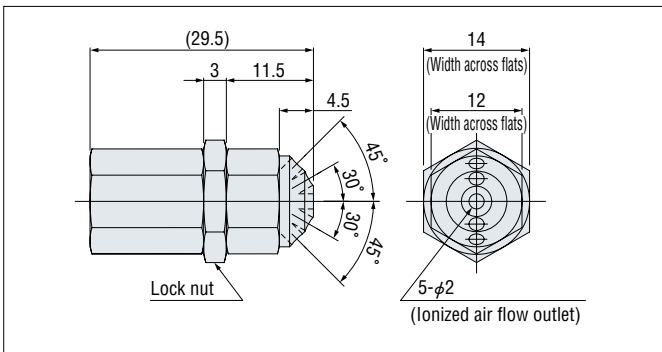

● Bender bar nozzle unit **DTRY-ADN-□00B**

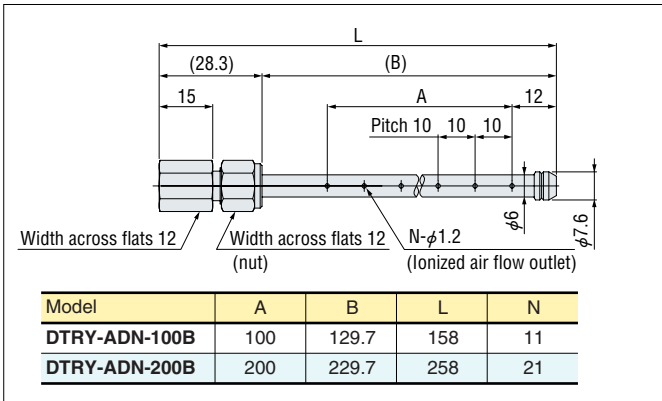

Remark: Loosen the nut to adjust the direction of the ionized air flow outlet.
 Note: Do not contact the nozzle with a grounded conductive object.
 The abnormality indicator LED may turn on.

Dimensions of Common Options for **BLOW TYPE** and **COMPACT BLOW TYPE** (mm)

TUBES

● Conductive urethane tube **DTRY-ADN-U**

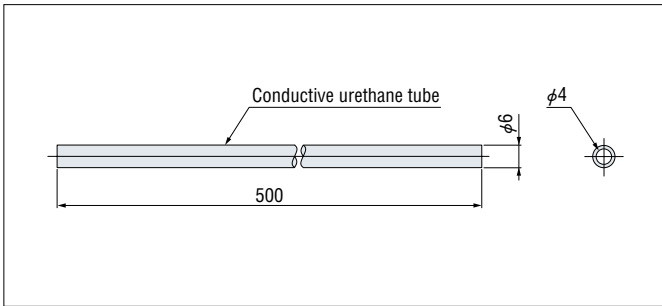

● Teflon tube **DTRY-ADN-F**

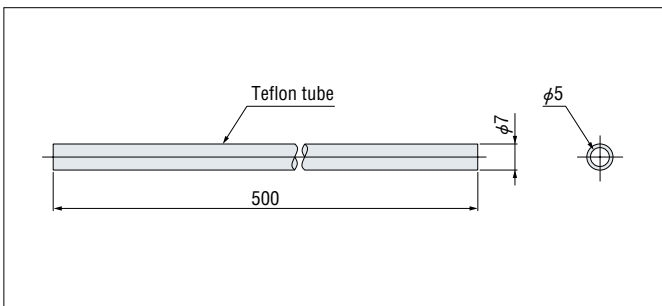

Note: The **DTRY-ADN-F** cannot be used for the earlier standard nozzles **DTRY-NZR01S** and **DTRY-NZL01S**.

● Silicone tube **DTRY-ADN-S**

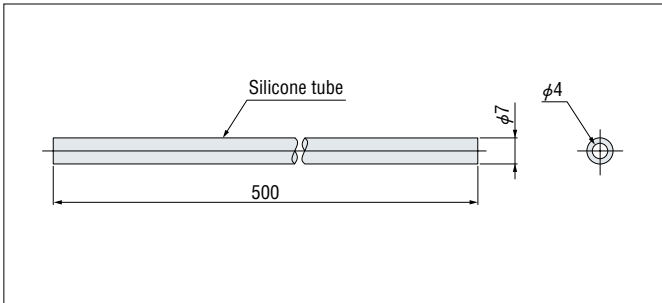

Note: The **DTRY-ADN-S** cannot be used for the earlier standard nozzles **DTRY-NZR01S** and **DTRY-NZL01S**.

■ Conductive urethane tube holder **DTRY-NZR31**

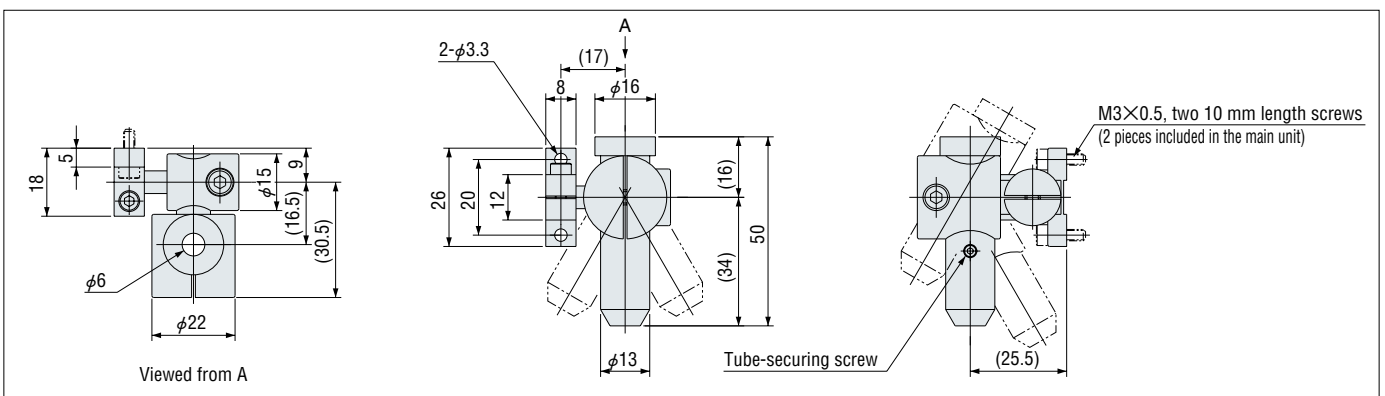

Note: The tube holder is the dedicated model for the conductive urethane tube **DTRY-ADN-U**. It cannot be used with the Teflon tube **DTRY-ADN-F** and the silicone tube **DTRY-ADN-S**.

CONTROLLER (For Blow Type and Compact Blow Type)

● DTRY-ELC11

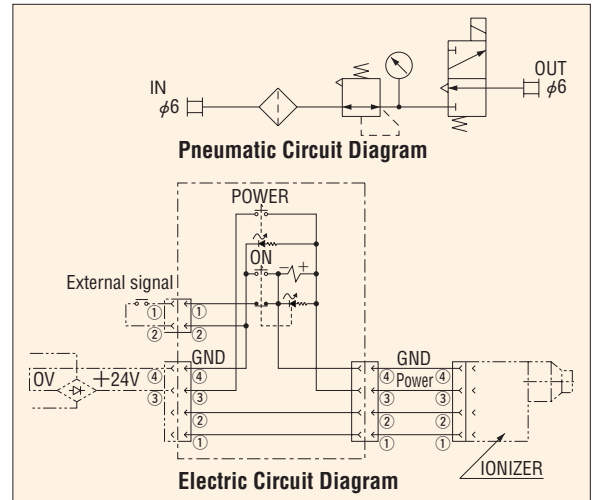
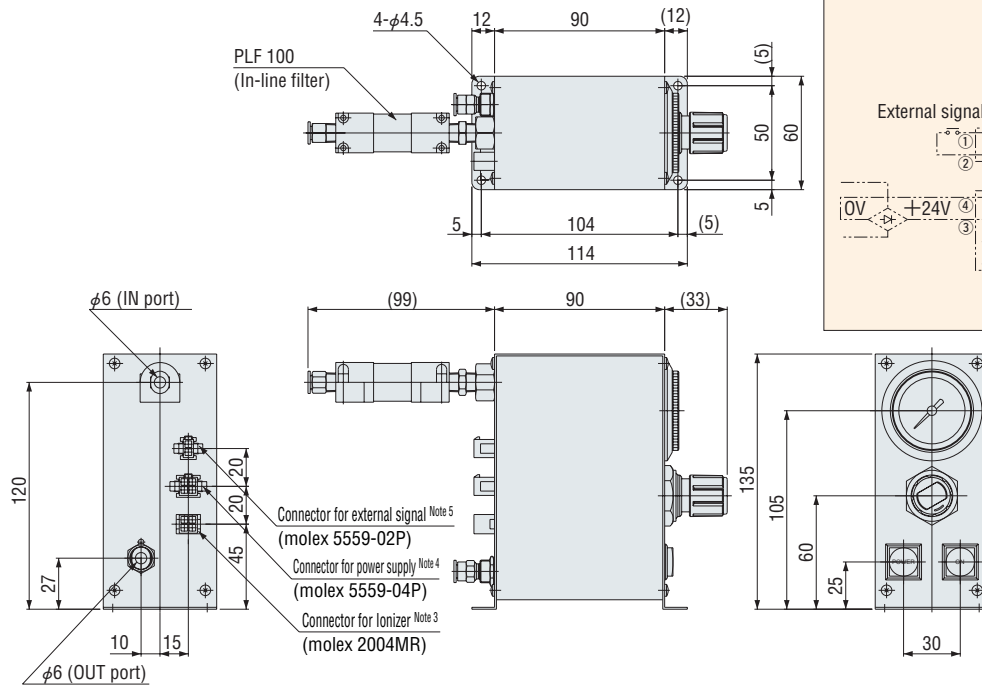

Notes:

1. The Controller is for the Blow Type Ionizer.
2. Provide 24 VDC power with 410 mA or larger.
For an AC adapter, use the **DTRY-ELC04**.
3. The cable used to connect the controller and the Ionizer is included in the product.
4. For a power supply cable, use the power and signal cable in the Ionizer accessories.
5. Separately purchase a cable for external signals.
6. Ground the controller power supply and the Ionizer separately.

Graphs of Static charge Removing Characteristics (Blow Type)

The following graphs show static charge removing characteristics obtained when using the blow type ionizer, DTRY-ELB01 (1-head type) with typical nozzles. Using the proper item to the proper place enables static charge removal with superior ion balance.

Notes 1: The static charge removing characteristics are measured by in-house test standard using the charged plate monitor of 20 pF, □150 mm.

2: The static charge removal time means decaying time from ±1000 V to ±100 V.

Photo shows a full-size

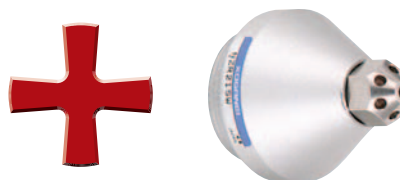

Various Nozzles

※ For the graph of static charge removing characteristics obtained when using the standard nozzle DTRY-NZR01NS, see page 10.

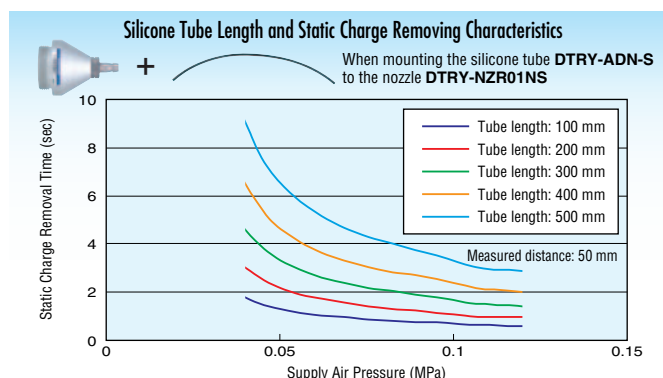
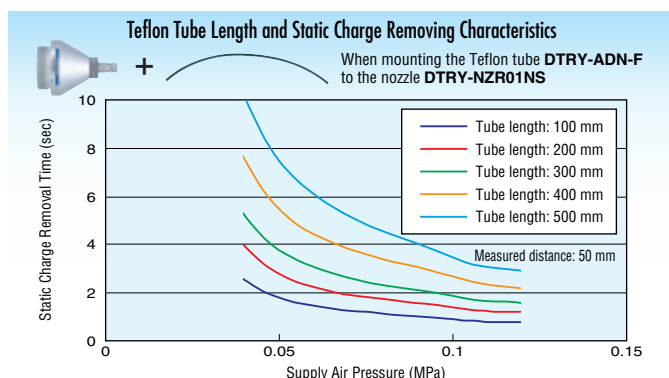
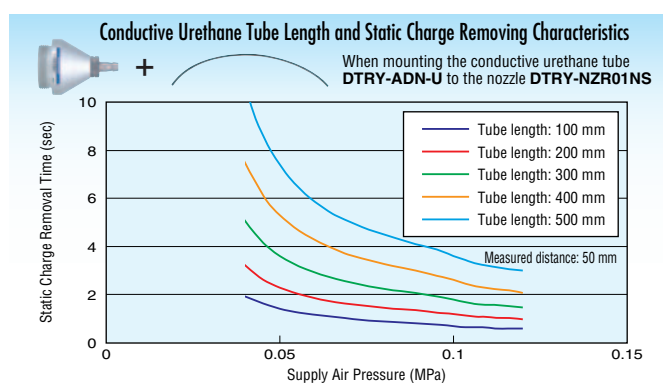
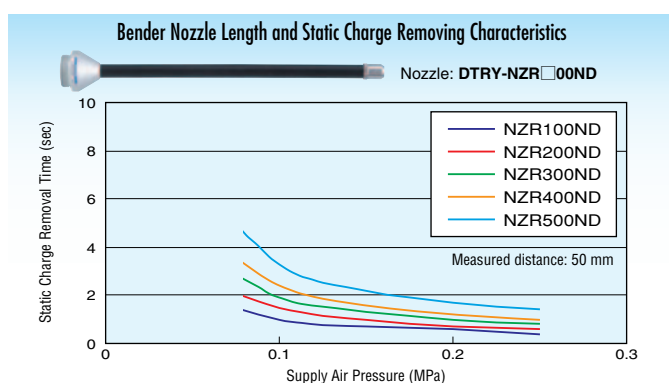

Graphs of Static charge Removing Characteristics

BLOW TYPE

Static Charge Removing Characteristics obtained when the Nozzle with Stainless Steel Pipe is used

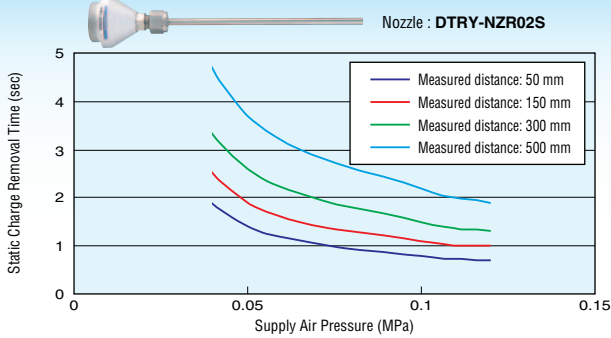

Static Charge Removing Characteristics obtained when Shower Nozzle (60° type) is used

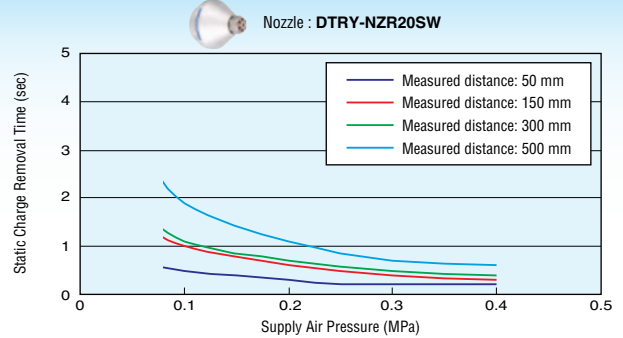

Static Charge Removing Characteristics obtained when Shower Nozzle (90° type) is used

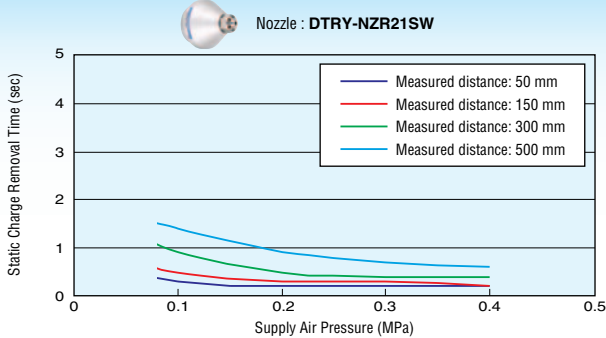

Static Charge Removing Characteristics obtained when the Flat Nozzle is used

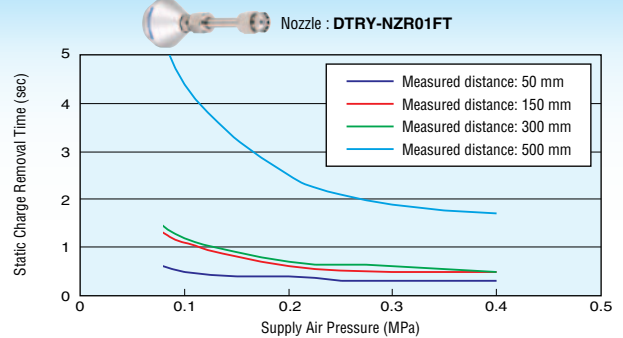

Static Charge Removing Characteristics obtained when the Spiral Bar Nozzle is used

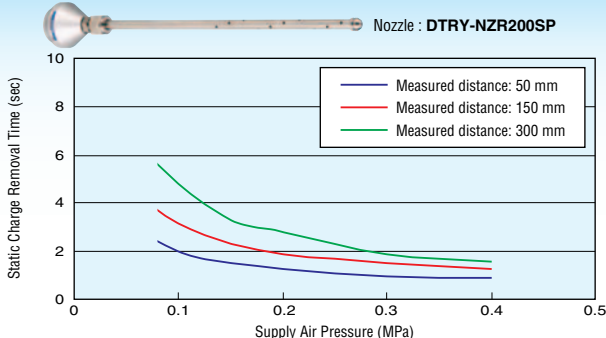

Static Charge Removing Characteristics obtained when the Straight Bar Nozzle (100 mm) is used

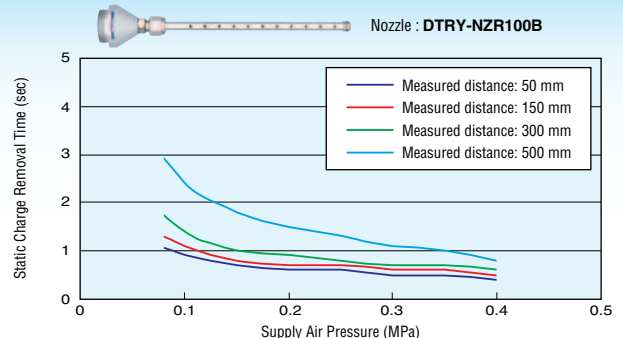

Static Charge Removing Characteristics obtained when the Straight Bar Nozzle (200 mm) is used

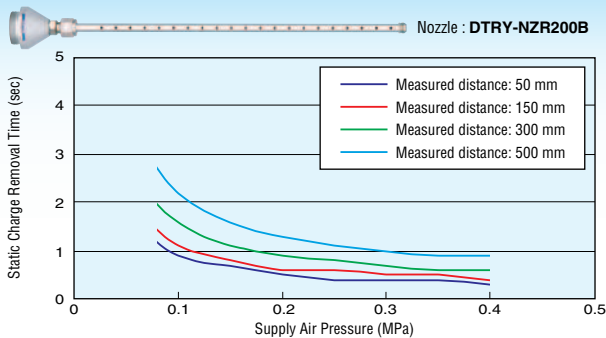

Static Charge Removing Characteristics obtained when the Straight Bar Nozzle (300 mm) is used

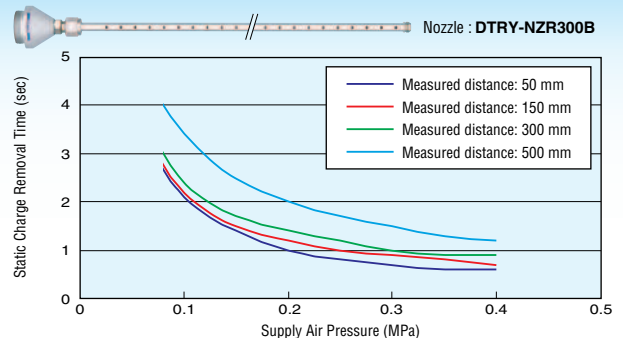

Static Charge Removing Characteristics obtained when the Straight Bar Nozzle (400 mm) is used

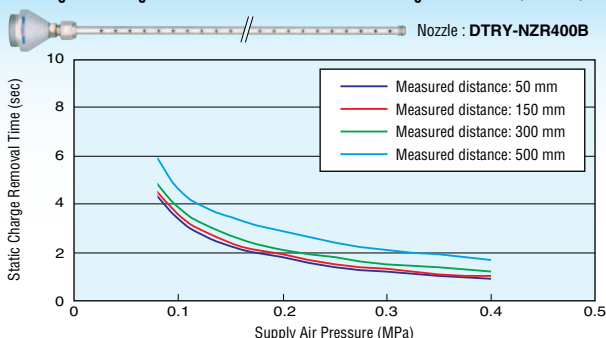

Static Charge Removing Characteristics obtained when the Straight Bar Nozzle (500 mm) is used

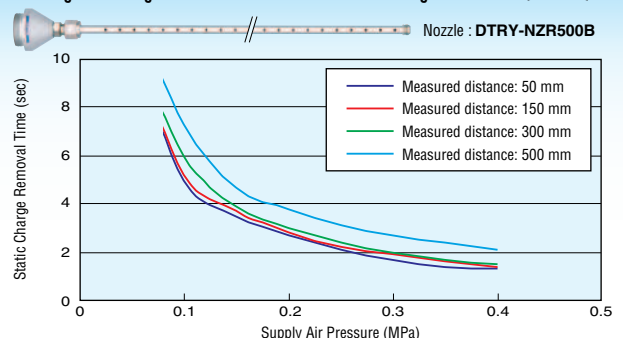

Graphs of Static charge Removing Characteristics

Static Charge Removing Characteristics obtained when the L-shaped Bar Nozzle (100 mm) is used

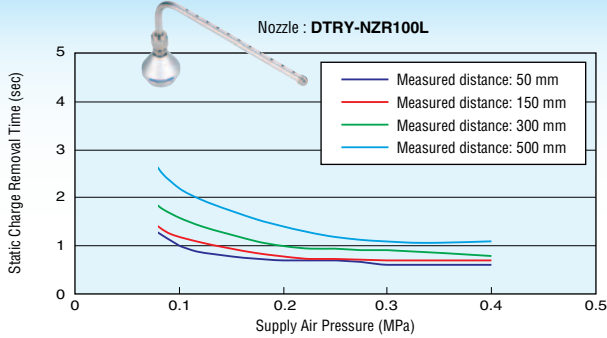

Static Charge Removing Characteristics obtained when the L-shaped Bar Nozzle (200 mm) is used

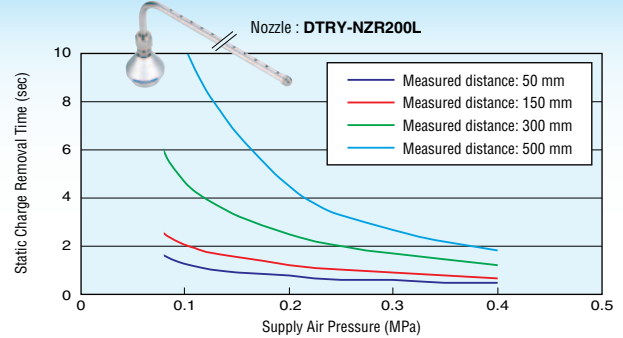

Static Charge Removing Characteristics obtained when the Free-mounting L-shaped bar nozzle (100 mm) is used

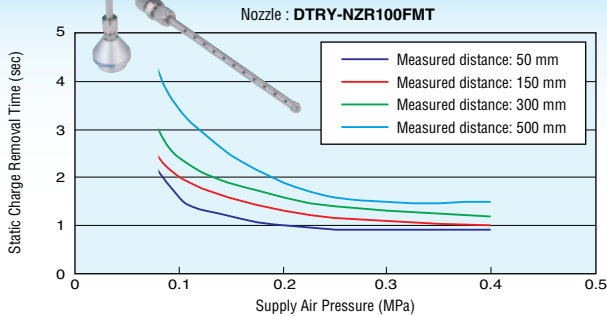

Static Charge Removing Characteristics obtained when the Free-mounting L-shaped bar nozzle (200 mm) is used

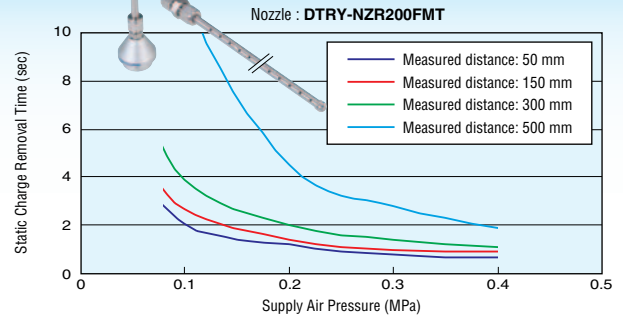

Static Charge Removing Characteristics obtained when the U-shaped Bar Nozzle is used

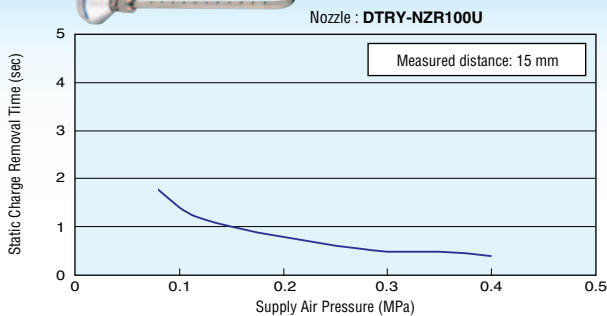

Bender Nozzle Length and Static Charge Removing Characteristics (Shower Nozzle 60° Type)

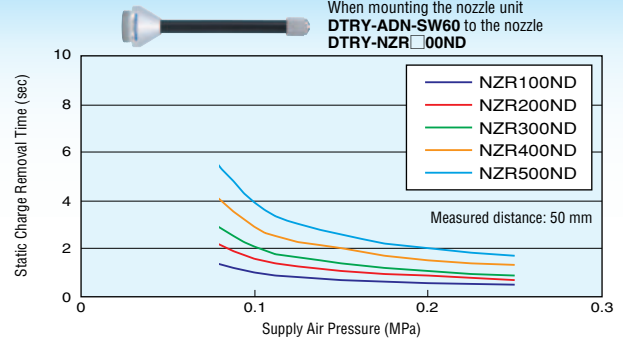

Bender Nozzle Length and Static Charge Removing Characteristics (Shower Nozzle 90° Type)

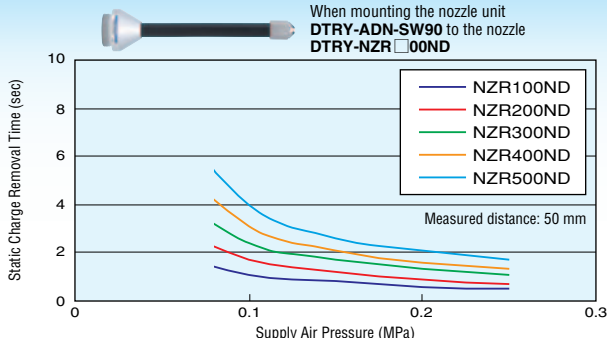

Bender Nozzle Length and Static Charge Removing Characteristics (Flat Nozzle)

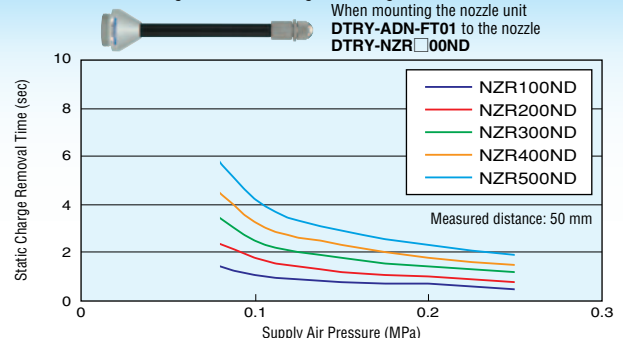

Bender Nozzle Length and Static Charge Removing Characteristics (Straight Bar Nozzle 100 mm)

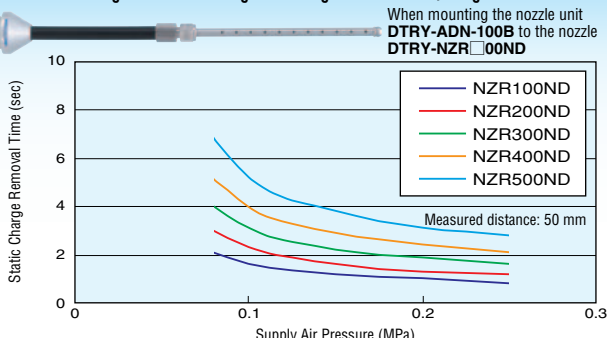

Bender Nozzle Length and Static Charge Removing Characteristics (Straight Bar Nozzle 200 mm)

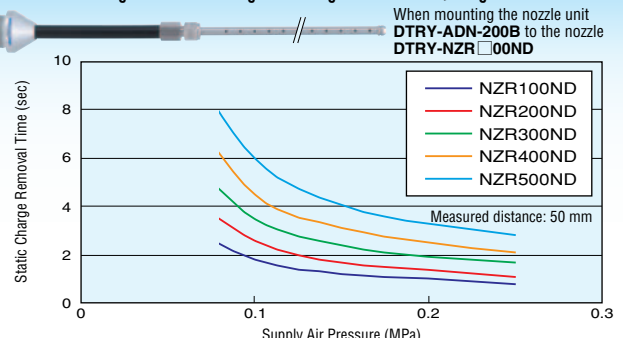

1 MPa = 145psi.