

35H-3 3.5MPa HYDRAULIC CYLINDER

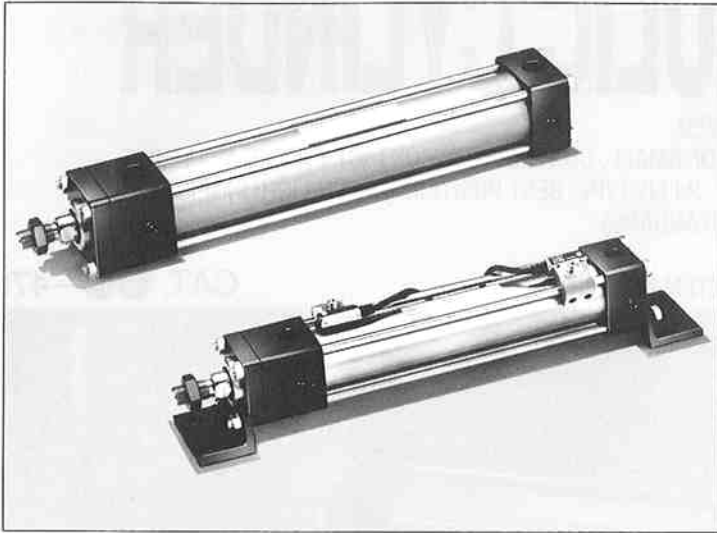

3.5MPa DOUBLE ACTING HYDRAULIC CYLINDER WITH BORE $\phi 32 \sim \phi 160$

- For switch set, $\phi 32 \sim \phi 100$ has been standardized.
- For magnetic proximity switch, the selection of small, contact • non-contact type is available. For non-contact switch, the setting of 2-wire, 2-LED type, best position (green lighting) is easy. WR • WS type switch is also mountable. (Semi-standard)
- The standard piston seal is U seal.
- For cushion structure, the metal cushion system is adopted.

CYLINDER SPECIFICATIONS

Type	Fundamental type		Switch set (Magnetic proximity type)	
Code	35H-3		35H-3R	
Piston seal	U-seal	Slipper seal (Semi-standard)	U-seal	Slipper seal (Semi-standard)
Cylinder bore mm	$\phi 32 \cdot \phi 40 \cdot \phi 50 \cdot \phi 63 \cdot \phi 80 \cdot \phi 100 \cdot \phi 125 \cdot \phi 160$		$\phi 32 \cdot \phi 40 \cdot \phi 50 \cdot \phi 63 \cdot \phi 80 \cdot \phi 100$	
Max. operating pressure	3.5MPa			
Proof test pressure	5MPa			
Min. operating pressure	0.1MPa			
Speed range	8 ~ 300mm/s	0.1 ~ 300mm/s	8 ~ 300mm/s	0.1 ~ 300mm/s
Temperature range	- 10 ~ + 80°C (Ambient and oil temp.) (But, unfrozen)		- 10 ~ + 70°C (Ambient and oil temp.) (But, unfrozen)	
Structure of cushioning	Metal cushion			
Recommendable fluid	Petroleum-based fluid (In case of the use of other fluids, refer to the table for adaptation of fluids.)			
Tolerance for thread	ISO 965/3			
Tolerance of stroke	Max. 250mm ^{+1.0} ₀ Max. 251 ~ 1000mm ^{+1.4} ₀ 1001 ~ 2000mm ^{+1.8} ₀			
Mounting style	SD, LA, LB, FA, FB, CA, CB, TA, TC			
Accessories	Boots	Standard: Nylon tarpaulin Semi-standard: Chloroprene • Conex		
	Rod end attachments	Rod end eye (T type) • Rod end clevis with pin (Y type) • F joint (F type) ($\phi 32 \sim \phi 100$)		
	Others	CB bracket • TA/TC bracket		

Note) • Hydraulic pressure that is generated in cylinder due to the inertia of load shall be set at less than the maximum allowable pressure.

- The cylinder body is not applied to the cutting oil-proof specifications.
- Conex of boots is the registered trade mark of Teijin, Ltd.
- Slipper seal is the registered trade mark of Japan Bulker Industry Co.
- In case of the use of switch, the switch set cylinder shall be used.

STANDARD STROKE FABRICATION RANGE Unit: mm

Type	Bore	$\phi 32 \cdot \phi 40$	$\phi 50 \cdot \phi 63$	$\phi 80$	$\phi 100$	$\phi 125 \cdot \phi 160$
Fundamental		1000	1200	1600	1600	1800
Switch set		1000	1200	1600	1600	—

Note) • The above-mentioned is the maximum stroke to be fabricated as standard.
 • The buckling of piston rod shall be separately studied.
 • For stroke more than the above table, consult us.

LENGTH OF CUSHION STROKE Unit: mm

Cylinder bore	Cushion stroke (Length of cushion ring)
$\phi 32 \sim \phi 63$	16
$\phi 80 \sim \phi 125$	20
$\phi 160$	23

Note) • The length of cushion stroke to be used at stroke end.
 • It shall be noted that the cushion effect is weakened in case that it is suspended at over 5mm before without using at stroke end. In such case, contact us separately.

PROMPT STROKE Unit: mm

Bore	Stroke	Prompt stroke					
		50	100	150	200	250	300
$\phi 32$		○	○	○	○	○	○
$\phi 40$		○	○	○	○	○	○
$\phi 50$		○	○	○	○	○	○
$\phi 63$		○	○	○	○	○	○
$\phi 80$		○	○	○	○	○	○

3.5MPa HYDRAULIC CYLINDER **35H-3**

MAGNETIC PROXIMITY SWITCH SPECIFICATIONS (WITH CONTACT)

Code	With cord (1.5m)	AX101	AX111	—	—	—	SR401	—
	With cord (5m)	AX105	AX115	—	—	AX125	SR405	WR505 · WR515
	With connector (AC type)	—	—	AX11A	—	—	—	—
	With connector (DC type)	—	—	—	AX11B	—	—	—
Load voltage range	AC : 5 ~ 120V DC : 5 ~ 30V		AC : 5 ~ 120V DC : 5 ~ 30V		AC : 5 ~ 120V DC : 5 ~ 50V		AC80 ~ 220V	
Load current range	AC : 5 ~ 20mA DC : 5 ~ 40mA		AC : 5 ~ 20mA DC : 5 ~ 40mA		AC : 5 ~ 20mA DC : 5 ~ 40mA		2 ~ 300mA	
Maximum open/close capacity	AC : 2VA DC : 1.5W						30VA	
Inner drop voltage	TYP : 2V (at 10mA) 3V or less (at 40mA)				0V		2V or less	
Current leak	0mA		10µA or less		0mA		1mA or less	
Working time			1ms or less					
Return time			1ms or less				1ms or less	
Insulation resistance	100 MΩ or more at 500 MV DC (between case and cord)							
Voltage-proof	AC1500V 1 min (between case and cord)							
Shock resistance	294m/s ² (30G)(Non-repetition)							
Vibration-proof	Total amplitude 1.5mm, 10 ~ 55Hz (1 sweep, 1 min) 2 hours in X, Y, and Z directions				Shock 10G, 50 ~ 200Hz 2 hours in		Lateral oscillation 1.5mm 10 to 55Hz (1 sweep for 1 min) 2 hours in X, Y, and Z directions	
Ambient temperature	-10 ~ +70°C (at non-freezing condition)				-10+60°C (free of freeze)			
Wiring method	0.3mm ² 2-core Outer diameter 4mm Oil-proof cabtyre cord				0.5mm ² 2-cores Outer dia. φ6mm Oil-proof cabtyre cord		0.3mm ² 2-cores Outer dia. φ4mm Oil-proof cabtyre cord	
Protective structure	IP67 (IEC standards), JIS C0920 (dusts-proof, immersion-proof type)				With code : IP67 (IEC standards), JIS C0920 (dusts-proof type) With connector : IP64 (IEC standards), JIS C0920 (dusts-proof type)		IP67G (JEN standards)(oil-proof type)	
Contact protective circuit	Note) None		Equipped		Note) None		Equipped	
Indicating lamp	LED (red lamp lights up during ON)				None		Neon lamp (Lights at OFF)	
Electric circuit								
Applied load	Small relay • Programmable Controller				IC circuit, small relay, programmable controller		Small relay • Programmable Controller Small solenoid pilot lamp	

- Notes ● When using induction load devices (small relay, etc.), be sure to provide the protective circuit (SK-100).
● For the cord length and connector pin position of the connector type, refer to the dimensional drawings.

MAGNETIC PROXIMITY SWITCH SPECIFICATIONS (WITH NO CONTACT)

Code	With cord (1.5m)	AX201	AX211	—
	With cord (5m)	AX205	AX215	WS215 · WS225
Load voltage range	DC : 5 ~ 30V			DC : 10 ~ 30V
Load current range	DC : 5 ~ 40mA			DC : 6 ~ 7mA
Inner drop voltage	3V or less (at 40mA)			4V or lower
Current leak				1mA or less
Working time	1ms or less			—
Return time				1ms or less
Insulation resistance	100 MΩ or more at 500 MV DC (between case and cord)			
Voltage-proof	AC1500V 1 min (between case and cord)			
Shock resistance	490m/s ² (50G) (Non-repetition)			
Vibration-proof	Total amplitude 0.6mm, 10 ~ 200Hz (log sweep 1 hour) X, Y, Z each direction			
Ambient temperature	-10 ~ +70°C (at non-freezing condition)			-10 ~ +60°C (free of freeze)
Wiring method	0.3mm ² 2-core Outer diameter 4mm Oil-proof cabtyre cord			
Protective structure	IP67 (IEC standards), JIS C0920 (dusts-proof, immersion-proof type)			IP67G (JEN standards)(oil-proof type)
Contact protective circuit	Equipped			
Indicating lamp	LED (red lamp lights up during ON)		Working position : red/green LED lights up Most suitable position : green LED lights up	
Electric circuit				
Applied load	Small relay • Programmable Controller			

35H-3 3.5MPa HYDRAULIC CYLINDER

MIN. STROKE OF SWITCH SET CYLINDER

Unit: mm

Bore mm	Mounting code Switch Q'ty Switch type	Except TC type						TC type					
		1 switch mounted			2 switches mounted			1 switch mounted			2 switches mounted		
		AX·AZ	WR·WS	SR	AX·AZ	WR·WS	SR	AX·AZ	WR·WS	SR	AX·AZ	WR·WS	SR
φ32		25	55 (40)	35	25	55 (40)	35	55	85 (70)	65	105	165 (140)	130
φ40		25	55 (40)	35	25	55 (40)	35	55	85 (70)	65	105	165 (140)	130
φ50		25	55 (40)	35	25	55 (40)	35	55	85 (70)	65	105	165 (140)	130
φ63		20	55 (40)	35	20	55 (40)	35	55	85 (70)	65	105	165 (140)	130
φ80		20	55 (40)	35	20	55 (40)	35	55	85 (75)	70	105	165 (145)	135
φ100		20	55 (40)	35	20	55 (40)	35	60	90 (80)	75	110	165 (150)	140

- Note) ● For TC type with 1 switch mounted, it is a cylinder stroke in the case that TC type attachments are set at those except the center.
 ● For the minimum PH dimension of TC type for mounting switch, refer to the dimensional drawings of TC type.
 ● Concerning WR·WS, the dimension of () is the minimum stroke in which WR515, WS225 are available.

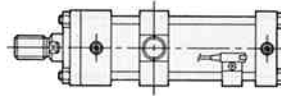
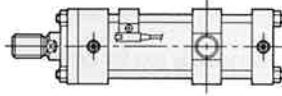

ALLOWABLE FLUID, SEAL MATERIAL

Code	Seal material	Allowable fluid				
		Petroleum-based fluid	Water-Glycol fluid	Phosphate-Ester fluid	Water in oil fluid	Oil in water fluid
1	Nitrile rubber	○	○	×	○	○
3	Fluoric rubber	○	×	○	○	○
6	HNBR (NEM)	○	◎	×	◎	◎
8	Slipper seal	○	○	×	○	○

- Note) 1. ◎ ○ Allowable × Unallowable
 2. ◎ indicates seal materials recommended in case that importance is attached to abrasion-proof.

In case of the use of fluids other than petroleum-based fluids, refer to the table for adaptation of fluids and seal material.

- Slipper seal is the registered trade mark of Bulker Industry Co.

WEIGHT TABLE

Unit: kgf

Bore mm	Fundamental type-Switchset 35H-3-35H-3R		Additional switch weight						Mounting accessories weight							Bracket weight		Rod end attachment weight			
	Basic weight (SD)	Additional weight per 1mm of stroke	1 piece						LA	LB	FA	FB	CA	CB	TA	TC	CB bracket	TA/TC bracket	Eye (T type)	Clevis (Y type) with pin	F joint (F type)
			AX·AZ		WR·WS	SR															
φ32	1.17	0.0041	0.05	0.13			0.04	0.5	0.1	0.22	0.12	0.19	0.17	0.24	0.12	0.12	0.051	0.30	0.48	0.42	0.15
φ40	1.77	0.0045			0.19	0.23					0.25	0.32	0.18	0.15	0.193	0.48	0.60	1.2	0.16	0.34	0.19
φ50	2.56	0.0078			0.28	0.36					0.41	0.50	0.26	0.30	0.193	0.56	0.60	1.2	0.22	0.35	0.41
φ63	3.98	0.0094			0.29	0.46					0.56	0.64	0.40	0.38	0.193	0.70	0.60	1.2	0.22	0.35	0.41
φ80	7.55	0.0122			0.66	0.86					1.40	1.56	1.02	0.82	0.193	1.15	1.61	1.6	0.76	1.01	1.41
φ100	11.44	0.020	0.07	0.14	0.06				0.96	1.60	1.96	2.25	1.28	1.38	0.405	3.10	3.24	3.81	1.30	1.76	2.68
φ125	18.58	0.033	—	—	—	—	—	—	1.42	2.24	3.76	4.24	4.24	4.42	0.576	4.80	6.37	6.62	3.19	4.36	—
φ160	35.03	0.049	—	—	—	—	—	—	2.60	5.68	7.76	8.78	8.05	8.91	1.125	6.10	13.74	12.64	4.29	5.82	—

Calculation formula: Cylinder weight (kgf) = Basic weight + Additional switch weight + Mounting accessories weight + Additional weight per 1mm of stroke × Cylinder stroke mm

Calculation example: Switch set cylinder bore φ80mm, 2-YS type switches (cord length 5m), LA type, Cylinder stroke 200mm.
 $7.55 + 0.1 \times 2 + 0.66 + 0.0122 \times 200 = 10.85\text{kg}$

3.5MPa HYDRAULIC CYLINDER **35H-3**

TYPE OUTLINE•CODE

FUNDAMENTAL TYPE



CODE

35H-3 1 LA 50 B 100 - T - J

Series ① ② ③ ④ ⑤ ⑧ ⑨

Note) The above is the case of with cushion at both sides•port position (A) and cushion needle position (B). But, for the case of no cushion (N), it is the port position (A)•cushion needle position 0.

SWITCH SET

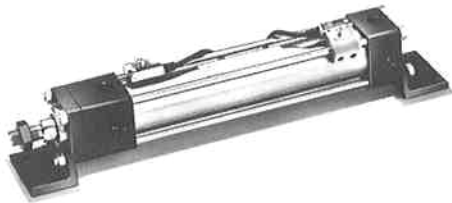

CODE

35H-3R 1 LB 50 B 100 - AH 2 - T - J

Series ① ② ③ ④ ⑤ ⑥ ⑦ ⑧ ⑨

Note) The above is the case of with cushion at both sides•port position (A) and cushion needle position (B). But, for the case of no cushion (N), it is the port position (A)•cushion needle position 0.

ORDER OUTLINE

- Standard specifications
 - With cushion at both sides
 - Port position (A), cushion needle position (B)
 - Seal material is U seal (nitrile rubber).
- The following are available as semi-standard.
 - With boots
 - Modification of TC mounting position (dimensional symbol PH)
 - Modification of piston rod end (dimensional symbol W•WF•A•KK)
 - Piston seal is modified to slipper seal (speed 8mm/s or less)
 - Plated cylinder body (hard chrome-plated 2/100mm)
 - Magnetic proximity switch WR•WS•SR•SS
- Standard position of ports is (A) and that of cushion needles is (B). In case of positional modification, indicate "Symbol" as shown in "Dimensional drawings."

35H-3R 1LB50B100-B C AH2-J

Series Port position (A•B•C•D) Cushion needle position (A•B•C•D•0)

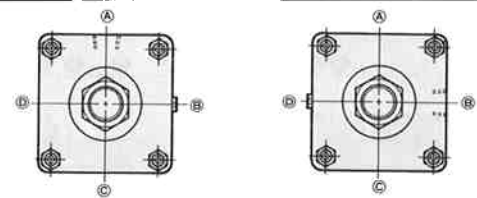

Case of A B

Case of B D

- In case of TA type, the standard position of port and cushion is (A) and (C) for head cover, (A) and (B) for cap.
 - In case of "no cushion," position of cushion needles is indicated as 0.
- Order method in case of with bracket.

35H-3R 1 CB 50B100-AH2-B-J

With bracket Mounting style CB type•TA type•TC type

Switch set cylinder is delivered without mounting switch on cylinder body.

SYMBOL EXPLANATION

①	Seal material	
	1	U seal (Nitrile rubber)
	(3)	U seal (Fluoric rubber)
	(6)	U seal (HNBR)
②	Mounting style (SD•LA•LB•FA•FB•CA•CB•TA•TC)	
	(8)	Slipper seal (Nitrile rubber + Fluoric resin 3UB)
③	Cushioning	
	B	Cap and head cover cushioned
	H	Cap cushioned
	R	Head cover cushioned
	N	No cushion
④	Cylinder stroke (mm)	

- Parenthesized are semi-standard.
- In switch symbols, only switch body WR505•WS215 and straight box connector (F-SB) are set for (5)•(2). For (7)•(4), switch body, straight box connector (F-SB) and flexible tube (code: F-05 length 4.8m) are set.

⑥	Switch symbol		
	With contact	AF	AX101 (With code 1.5m)
		AG	AX105 (With code 5m)
		AH	AX111 (With code 1.5m)
		AJ	AX115 (With code 5m)
		AE	AX125 (With code 5m)
		AK	AX11A (With code 0.5m)
		AL	AX11B (With code 0.5m)
		(5)	WR505 (With code 5m) (Water-proof type)
		(7)	WR505 (With code 5m) (Water-proof/flexible tube attached)
		(6)	WR515 (With code 5m)
	(H)	SR401 (With code 1.5m)	
	(S)	SR405 (With code 5m)	
	With no contact	BE	AX201 (With code 1.5m)
		BF	AX205 (With code 5m)
CE		AX211 (With code 1.5m)	
CF		AX215 (With code 5m)	
(2)		WS215 (With code 5m) (Water-proof type)	
(4)	WS215 (With code 5m) (Water-proof/flexible tube attached)		
(3)	WS225 (With code 5m)		
⑦	Quantity of switches		
	Rod end code		
	T	Rod end eye (T Type)	
⑧	Y	Rod end clevis (Y Type)	
	F	Self aligning rod end coupler (F Type)	
⑨	With boots		
	J	Nylon tarpaulin	
	(JN)	Chloroprene	
	(JK)	CONEX	

35H-3 3.5MPa HYDRAULIC CYLINDER

DIMENSIONAL DRAWINGS/SD TYPE (BASIC TYPE)

Unit: mm

FUNDAMENTAL TYPE

35H-3 Seal material SD Bore B Stroke

Series

• There are check valves for 2 surfaces of 4 outer circumference surfaces of cap and head cover except port and cushion surfaces. Check valve is concurrently used with air vent.

SWITCH SET

35H-3R Seal material SD Bore B Stroke - Switch

Series

• YR type (With contact) • YS type (With no contact/2-wire, 2-LED type)

• WR type (With contact) • WS type (With no contact/2-wire, 2-LED type) (Water-proof type)

• UX dimension is the best position for mounting switch when stroke end is detected.
 • All dimensions of cylinder are the same as those for fundamental type.
 • For minimum stroke of switch set cylinder, refer to "Cylinder specifications."
 • For the switch mounting method, refer to "Setting Method of Switch Detecting Position" of the Mounting Outline.

DIMENSIONAL TABLE

Symbol	A	B	B ₁	BB	D	DD	E	EE	F	FP	H	h	J	K	KK	LF	MM
φ32	24	φ30	19	7	13	M6 × 1	□ 44	Rc 1/4	10	34	30	7	38	25	M12 × 1.25	103	φ16
φ40	24	φ30	19	7	13	M6 × 1	□ 50	Rc 3/8	10	34	30	7	38	25	M12 × 1.25	103	φ16
φ50	36	φ34	24	7	19	M6 × 1	□ 62	Rc 3/8	10	34	30	11	38	25	M18 × 1.5	103	φ22
φ63	36	φ34	24	9	19	M8 × 1.25	□ 76	Rc 3/8	10	34	33	11	38	25	M18 × 1.5	106	φ22
φ80	48	φ42	32	10	24	M10 × 1.25	□ 94	Rc 1/2	16	43	31	14	45	32	M24 × 2	124	φ28
φ100	60	φ50	41	12	30	M12 × 1.5	□114	Rc 1/2	16	43	31	17	45	32	M30 × 2	124	φ36
φ125	84	φ60	60	16	41	M16 × 1.5	□138	Rc 1/2	20	47	37	22	45	32	M42 × 2	134	φ45
φ160	96	φ72	70	19	50	M20 × 1.5	□178	Rc 3/4	25	54	42	26	50	38	M48 × 2	155	φ56

Symbol	P	RN			RR	RV			RY			UX					W	ZB	ZJ
		AX-AZ	WR-WS	SR		AX-AZ	WR-WS	SR	AX-AZ	WR-WS	SR	With contact		With no contact					
Bore																			
φ32	58	7	5	5	□ 33	34	37	37	68	74	74	5	0	2	5	5	15	125	118
φ40	58	5	5	4	□ 37	36	41	40	72	82	80	5	0	2	5	5	15	125	118
φ50	58	4	3	4	□ 47	41	46	45	82	92	90	5	0	2	5	5	15	125	118
φ63	61	3	3	4	□ 56	47	51	51	94	102	102	6	1	3	6	6	15	130	121
φ80	67	3	1	3	□ 70	54	59	59	108	118	118	4	0	2	4	4	19	153	143
φ100	67	4	1	1	□ 89	63	68	68	126	136	136	4	0	2	4	4	23	159	147
φ125	73	—	—	—	□110	—	—	—	—	—	—	—	—	—	—	—	25	175	159
φ160	84	—	—	—	□142	—	—	—	—	—	—	—	—	—	—	—	29	203	184

3.5MPa HYDRAULIC CYLINDER 35H-3

DIMENSIONAL DRAWINGS/LA TYPE (SIDE LUGS MOUNTING)

Unit: mm

35H-3 Seal material LA Bore B Stroke

Series

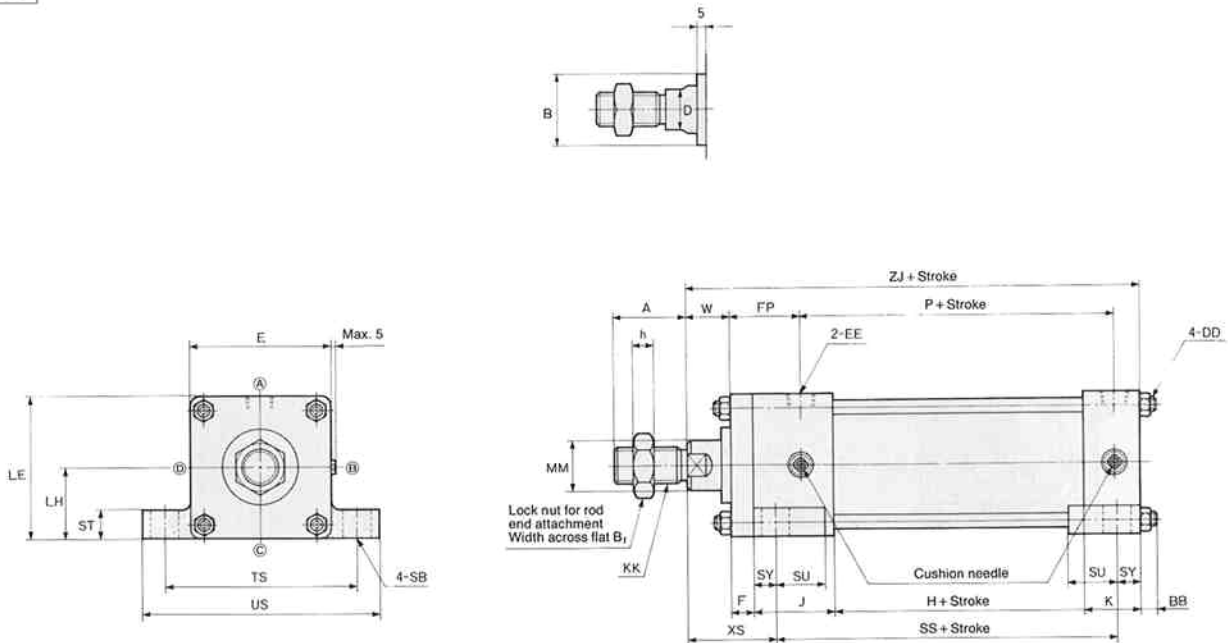

- There are check valves for 2 surfaces of 4 outer circumference surfaces of cap and head cover except port and cushion surfaces. Check valve is concurrently used with air vent.
- For other dimensions, refer to SD type (basic type).
- For dimension of switch set cylinder, refer to SD type (basic type).
- For dimension of cylinder with boot, refer to "Accessories."

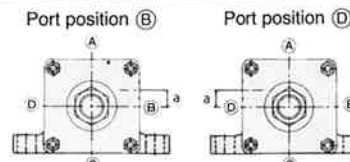

Note) Dimension of a for port position (B) or (D).

Bore Symbol	φ32	φ40	φ50	φ63	φ80	φ100	φ125	φ160
a	5	6	6	0	0	0	0	0

• It is also the same as for switch set cylinder.

DIMENSIONAL TABLE

Bore Symbol	A	B	B ₁	BB	D	DD	E	EE	F	FP	H	h	J	K	KK
φ32	24	φ30	19	7	13	M6 × 1	□ 44	Rc ¹ / ₄	10	34	30	7	38	25	M12 × 1.25
φ40	24	φ30	19	7	13	M6 × 1	□ 50	Rc ³ / ₈	10	34	30	7	38	25	M12 × 1.25
φ50	36	φ34	24	7	19	M6 × 1	□ 62	Rc ³ / ₈	10	34	30	11	38	25	M18 × 1.5
φ63	36	φ34	24	9	19	M8 × 1.25	□ 76	Rc ³ / ₈	10	34	33	11	38	25	M18 × 1.5
φ80	48	φ42	32	10	24	M10 × 1.25	□ 94	Rc ¹ / ₂	16	43	31	14	45	32	M24 × 2
φ100	60	φ50	41	12	30	M12 × 1.5	□114	Rc ¹ / ₂	16	43	31	17	45	32	M30 × 2
φ125	84	φ60	60	16	41	M16 × 1.5	□138	Rc ¹ / ₂	20	47	37	22	45	32	M42 × 2
φ160	96	φ72	70	19	50	M20 × 1.5	□178	Rc ³ / ₄	25	54	42	26	50	38	M48 × 2

Bore Symbol	LE	LH	MM	P	SB	SS	ST	SU	SY	TS	US	W	XS	ZJ
φ32	44	22 ^{-0.300} / _{-0.384}	φ16	58	φ9	73	8	18	10	69	84	15	35	118
φ40	50	25 ^{-0.300} / _{-0.384}	φ16	58	φ12	73	8	24	10	80	100	15	35	118
φ50	62	31 ^{-0.310} / _{-0.410}	φ22	58	φ12	73	12	24	10	92	112	15	35	118
φ63	76	38 ^{-0.310} / _{-0.410}	φ22	61	φ12	76	12	24	10	108	128	15	35	121
φ80	94	47 ^{-0.320} / _{-0.420}	φ28	67	φ14	82	19	32	13	128	150	19	48	143
φ100	114	57 ^{-0.340} / _{-0.450}	φ36	67	φ18	72	24	27	18	154	182	23	57	147
φ125	138	69 ^{-0.360} / _{-0.480}	φ45	73	φ22	70	29	23	22	189	224	25	67	159
φ160	178	89 ^{-0.380} / _{-0.520}	φ56	84	φ26	82	42	26	24	236	278	29	78	184

35H-3 3.5MPa HYDRAULIC CYLINDER

DIMENSIONAL DRAWINGS/LB TYPE (END ANGLES MOUNTING)

Unit: mm

35H-3 Seal material LB Bore B Stroke

Series

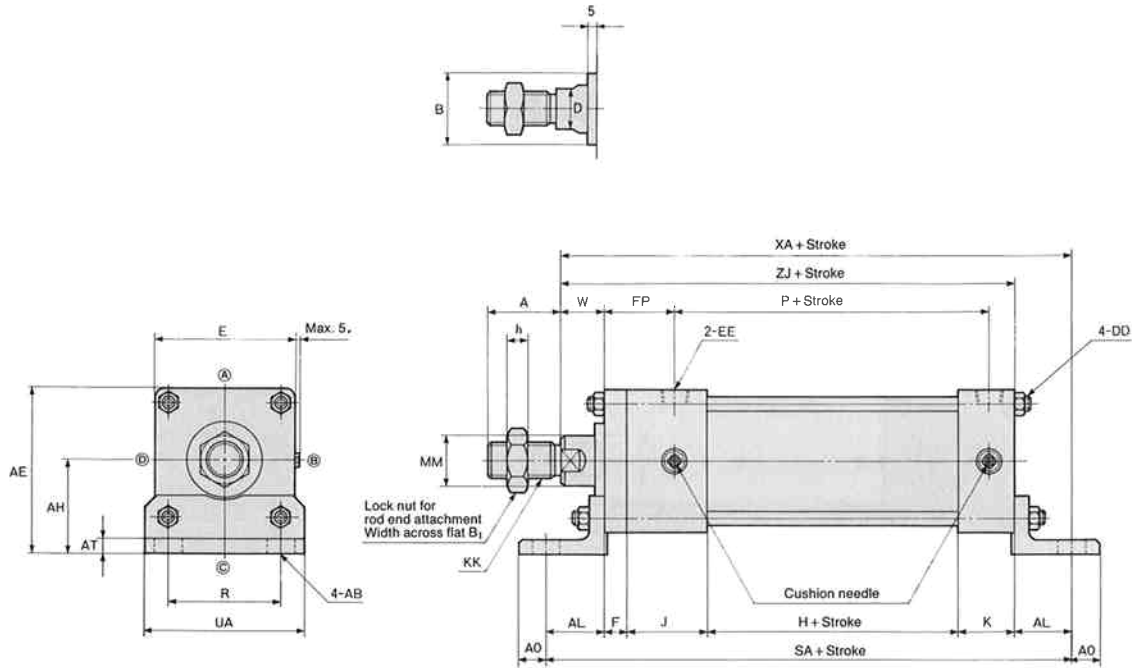

- There are check valves for 2 surfaces of 4 outer circumference surfaces of cap and head cover except port and cushion surfaces. Check valve is concurrently used with air vent.
- For other dimensions, refer to SD type (basic type).
- For dimension of switch set cylinder, refer to SD type (basic type).
- For dimension of cylinder with boot, refer to "Accessories."

DIMENSIONAL TABLE

Bore	Symbol	A	AB	AE	AH	AL	AO	AT	B	B ₁	D	DD	E	EE	F	FP
φ32		24	φ9	55	33	23	10	5	φ30	19	13	M6 × 1	□ 44	Rc ¹ / ₄	10	34
φ40		24	φ12	60	35	25	12	5	φ30	19	13	M6 × 1	□ 50	Rc ³ / ₈	10	34
φ50		36	φ12	72	41	26	12	6	φ34	24	19	M6 × 1	□ 62	Rc ³ / ₈	10	34
φ63		36	φ12	86	48	28	12	6	φ34	24	19	M8 × 1.25	□ 76	Rc ³ / ₈	10	34
φ80		48	φ14	106	59	34	14	8	φ42	32	24	M10 × 1.25	□ 94	Rc ¹ / ₂	16	43
φ100		60	φ18	127	70	40	18	9	φ50	41	30	M12 × 1.5	□114	Rc ¹ / ₂	16	43
φ125		84	φ22	155	86	47	22	10	φ60	60	41	M16 × 1.5	□138	Rc ¹ / ₂	20	47
φ160		96	φ26	200	111	58	26	15	φ72	70	50	M20 × 1.5	□178	Rc ³ / ₄	25	54

Bore	Symbol	H	h	J	K	KK	MM	P	R	SA	UA	W	XA	ZJ
φ32		30	7	38	25	M12 × 1.25	φ16	58	33	149	54	15	141	118
φ40		30	7	38	25	M12 × 1.25	φ16	58	37	153	60	15	143	118
φ50		30	11	38	25	M18 × 1.5	φ22	58	47	155	70	15	144	118
φ63		33	11	38	25	M18 × 1.5	φ22	61	56	162	80	15	149	121
φ80		31	14	45	32	M24 × 2	φ28	67	70	192	97	19	177	143
φ100		31	17	45	32	M30 × 2	φ36	67	89	204	120	23	187	147
φ125		37	22	45	32	M42 × 2	φ45	73	95	228	138	25	206	159
φ160		42	26	50	38	M48 × 2	φ56	84	128	271	178	29	242	184

3.5MPa HYDRAULIC CYLINDER 35H-3

DIMENSIONAL DRAWINGS/FA TYPE (HEAD FLANGE MOUNTING)

Unit: mm

35H-3 Seal material FA Bore B Stroke

Series

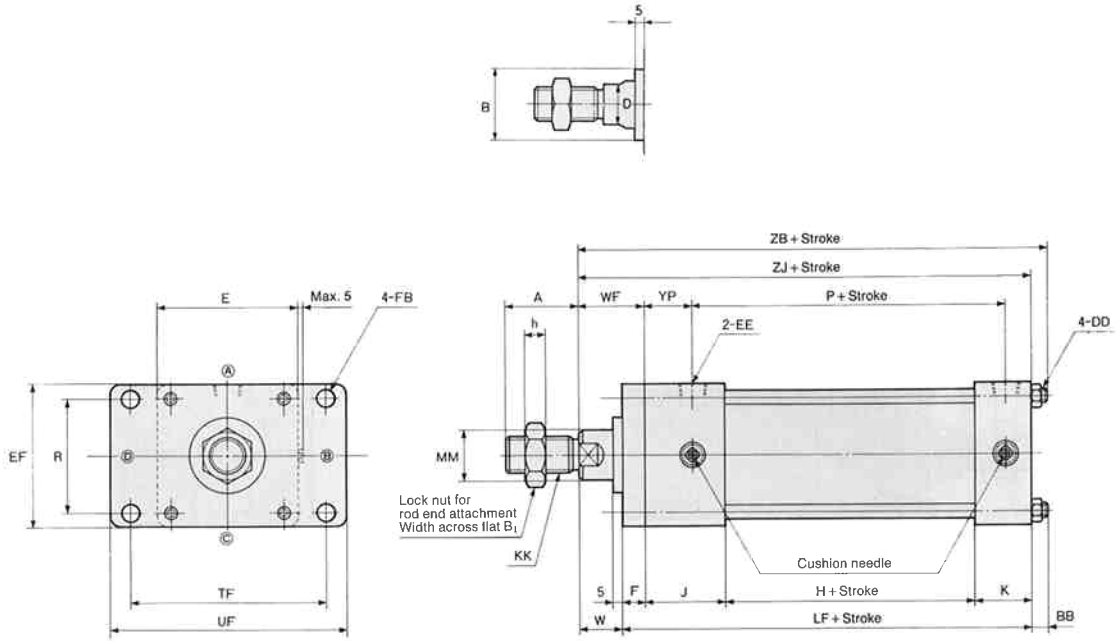

- There are check valves for 2 surfaces of 4 outer circumference surfaces of cap and head cover except port and cushion surfaces. Check valve is concurrently used with air vent.
- For other dimensions, refer to SD type (basic type).
- For dimension of switch set cylinder, refer to SD type (basic type).
- For dimension of cylinder with boot, refer to "Accessories."

DIMENSIONAL TABLE

Bore	Symbol	A	B	B ₁	BB	D	DD	E	EE	EF	F	FB	H	h	J	K
φ32		24	φ30	19	7	13	M6 × 1	□ 44	Rc ¹ / ₄	47	10	φ7	30	7	38	25
φ40		24	φ30	19	7	13	M6 × 1	□ 50	Rc ³ / ₈	52	10	φ7	30	7	38	25
φ50		36	φ34	24	7	19	M6 × 1	□ 62	Rc ³ / ₈	65	10	φ9	30	11	38	25
φ63		36	φ34	24	9	19	M8 × 1.25	□ 76	Rc ³ / ₈	76	10	φ9	33	11	38	25
φ80		48	φ42	32	10	24	M10 × 1.25	□ 94	Rc ¹ / ₂	95	16	φ12	31	14	45	32
φ100		60	φ50	41	12	30	M12 × 1.5	□114	Rc ¹ / ₂	115	16	φ14	31	17	45	32
φ125		84	φ60	60	16	41	M16 × 1.5	□138	Rc ¹ / ₂	138	20	φ18	37	22	45	32
φ160		96	φ72	70	19	50	M20 × 1.5	□178	Rc ³ / ₄	178	25	φ22	42	26	50	38

Bore	Symbol	KK	LF	MM	P	R	TF	UF	W	WF	YP	ZB	ZJ
φ32		M12 × 1.25	103	φ16	58	33	58	72	15	25	24	125	118
φ40		M12 × 1.25	103	φ16	58	36	70	84	15	25	24	125	118
φ50		M18 × 1.5	103	φ22	58	47	86	104	15	25	24	125	118
φ63		M18 × 1.5	106	φ22	61	56	98	116	15	25	24	130	121
φ80		M24 × 2	124	φ28	67	70	119	143	19	35	27	153	143
φ100		M30 × 2	124	φ36	67	84	140	166	23	39	27	159	147
φ125		M42 × 2	134	φ45	73	110	176	212	25	45	27	175	159
φ160		M48 × 2	155	φ56	84	142	225	270	29	54	29	203	184

35H-3 3.5MPa HYDRAULIC CYLINDER

DIMENSIONAL DRAWINGS/FB TYPE (CAP FLANGE MOUNTING)

Unit: mm

35H-3 Seal material FB Bore B Stroke

Series

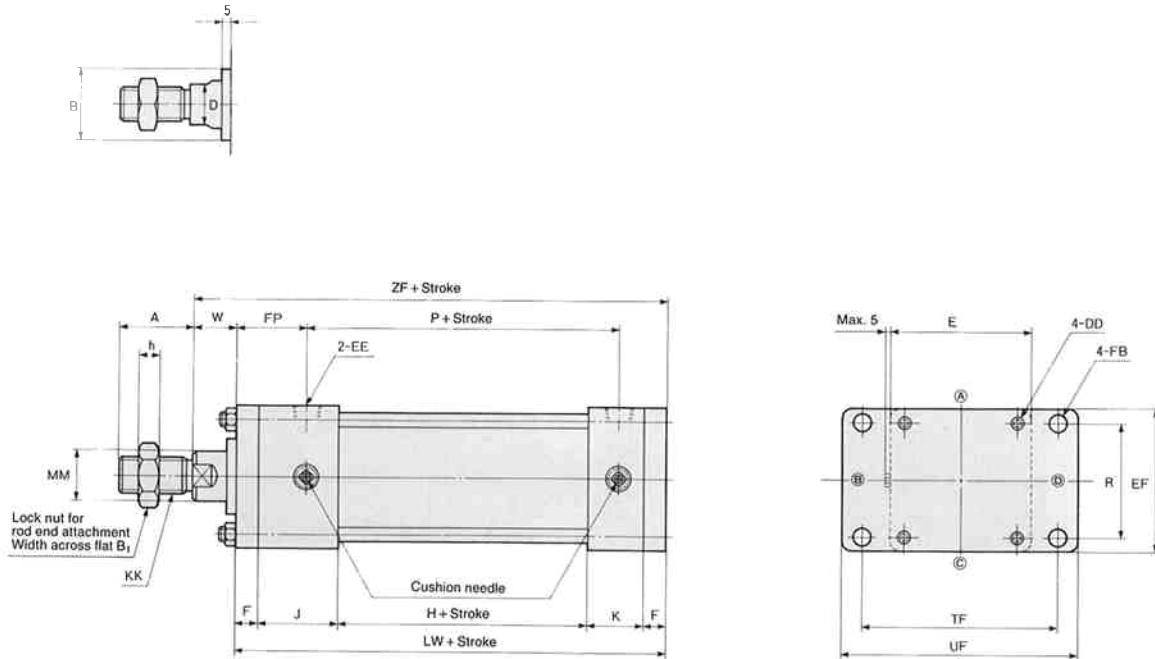

- There are check valves for 2 surfaces of 4 outer circumference surfaces of cap and head cover except port and cushion surfaces. Check valve is concurrently used with air vent.
- For other dimensions, refer to SD type (basic type).
- For dimension of switch set cylinder, refer to SD type (basic type).
- For dimension of cylinder with boot, refer to "Accessories."

DIMENSIONAL TABLE

Bore	Symbol	A	B	B ₁	D	DD	E	EE	EF	F	FB	FP	H	h
φ32		24	φ30	19	13	M6 × 1	□ 44	Rc ¹ / ₄	47	10	φ7	34	30	7
φ40		24	φ30	19	13	M6 × 1	□ 50	Rc ³ / ₈	52	10	φ7	34	30	7
φ50		36	φ34	24	19	M6 × 1	□ 62	Rc ³ / ₈	65	10	φ9	34	30	11
φ63		36	φ34	24	19	M8 × 1.25	□ 76	Rc ³ / ₈	76	10	φ9	34	33	11
φ80		48	φ42	32	24	M10 × 1.25	□ 94	Rc ¹ / ₂	95	16	φ12	43	31	14
φ100		60	φ50	41	30	M12 × 1.5	□114	Rc ¹ / ₂	115	16	φ14	43	31	17
φ125		84	φ60	60	41	M16 × 1.5	□138	Rc ¹ / ₂	138	20	φ18	47	37	22
φ160		96	φ72	70	50	M20 × 1.5	□178	Rc ³ / ₄	178	25	φ22	54	42	26

Bore	Symbol	J	K	KK	LW	MM	P	R	TF	UF	W	ZF
φ32		38	25	M12 × 1.25	113	φ16	58	33	58	72	15	128
φ40		38	25	M12 × 1.25	113	φ16	58	36	70	84	15	128
φ50		38	25	M18 × 1.5	113	φ22	58	47	86	104	15	128
φ63		38	25	M18 × 1.5	116	φ22	61	56	98	116	15	131
φ80		45	32	M24 × 2	140	φ28	67	70	119	143	19	159
φ100		45	32	M30 × 2	140	φ36	67	84	140	166	23	163
φ125		45	32	M42 × 2	154	φ45	73	110	176	212	25	179
φ160		50	38	M48 × 2	180	φ56	84	142	225	270	29	209

3.5MPa HYDRAULIC CYLINDER 35H-3

DIMENSIONAL DRAWINGS/CA TYPE (CAP EYE MOUNTING)

Unit: mm

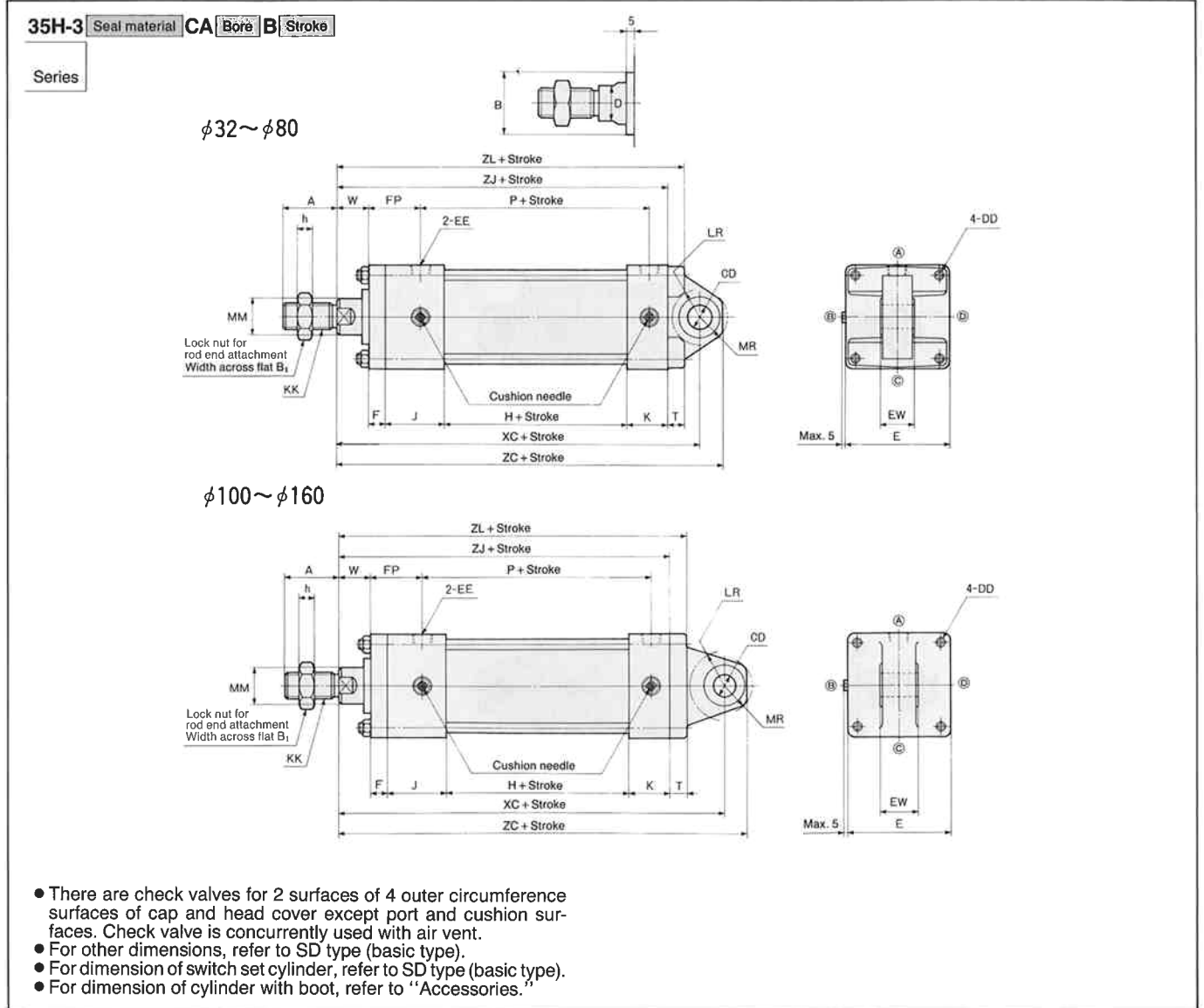

DIMENSIONAL TABLE

Bore	Symbol	A	B	B ₁	CD	D	DD	E	EE	EW	F	FP	H	h	J
$\phi 32$		24	$\phi 30$	19	$\phi 12H9$	13	M6 × 1	□ 44	Rc ¹ / ₄	16 ⁰ _{-0.070}	10	34	30	7	38
$\phi 40$		24	$\phi 30$	19	$\phi 14H9$	13	M6 × 1	□ 50	Rc ³ / ₈	20 ⁰ _{-0.084}	10	34	30	7	38
$\phi 50$		36	$\phi 34$	24	$\phi 14H9$	19	M6 × 1	□ 62	Rc ³ / ₈	20 ⁰ _{-0.084}	10	34	30	11	38
$\phi 63$		36	$\phi 34$	24	$\phi 14H9$	19	M8 × 1.25	□ 76	Rc ³ / ₈	20 ⁰ _{-0.084}	10	34	33	11	38
$\phi 80$		48	$\phi 42$	32	$\phi 20H9$	24	M10 × 1.25	□ 94	Rc ¹ / ₂	32 ⁰ _{-0.100}	16	43	31	14	45
$\phi 100$		60	$\phi 50$	41	$\phi 25H9$	30	M12 × 1.5	□ 114	Rc ¹ / ₂	40 ⁰ _{-0.100}	16	43	31	17	45
$\phi 125$		84	$\phi 60$	60	$\phi 32H9$	41	M16 × 1.5	□ 138	Rc ¹ / ₂	45 ⁰ _{-0.100}	20	47	37	22	45
$\phi 160$		96	$\phi 72$	70	$\phi 36H9$	50	M20 × 1.5	□ 178	Rc ³ / ₄	50 ⁰ _{-0.100}	25	54	42	26	50

Bore	Symbol	K	KK	LR	MM	MR	P	T	W	XC	ZC	ZJ	ZL
$\phi 32$		25	M12 × 1.25	R17	$\phi 16$	R14	58	8	15	137	149	118	126
$\phi 40$		25	M12 × 1.25	R17	$\phi 16$	R16	58	8	15	137	151	118	126
$\phi 50$		25	M18 × 1.5	R19	$\phi 22$	R16	58	10	15	137	151	118	128
$\phi 63$		25	M18 × 1.5	R19	$\phi 22$	R16	61	13	15	140	154	121	134
$\phi 80$		32	M24 × 2	R26	$\phi 28$	R22	67	18	19	175	195	143	161
$\phi 100$		32	M30 × 2	R32	$\phi 36$	R30	67	16	23	200	225	147	163
$\phi 125$		32	M42 × 2	R42	$\phi 45$	R36	73	19	25	226	258	159	178
$\phi 160$		38	M48 × 2	R45	$\phi 56$	R42	84	24	29	261	297	184	208

35H-3 3.5MPa HYDRAULIC CYLINDER

DIMENSIONAL DRAWINGS/CB TYPE (CAP CLEVIS MOUNTING) WITH PIN

Unit: mm

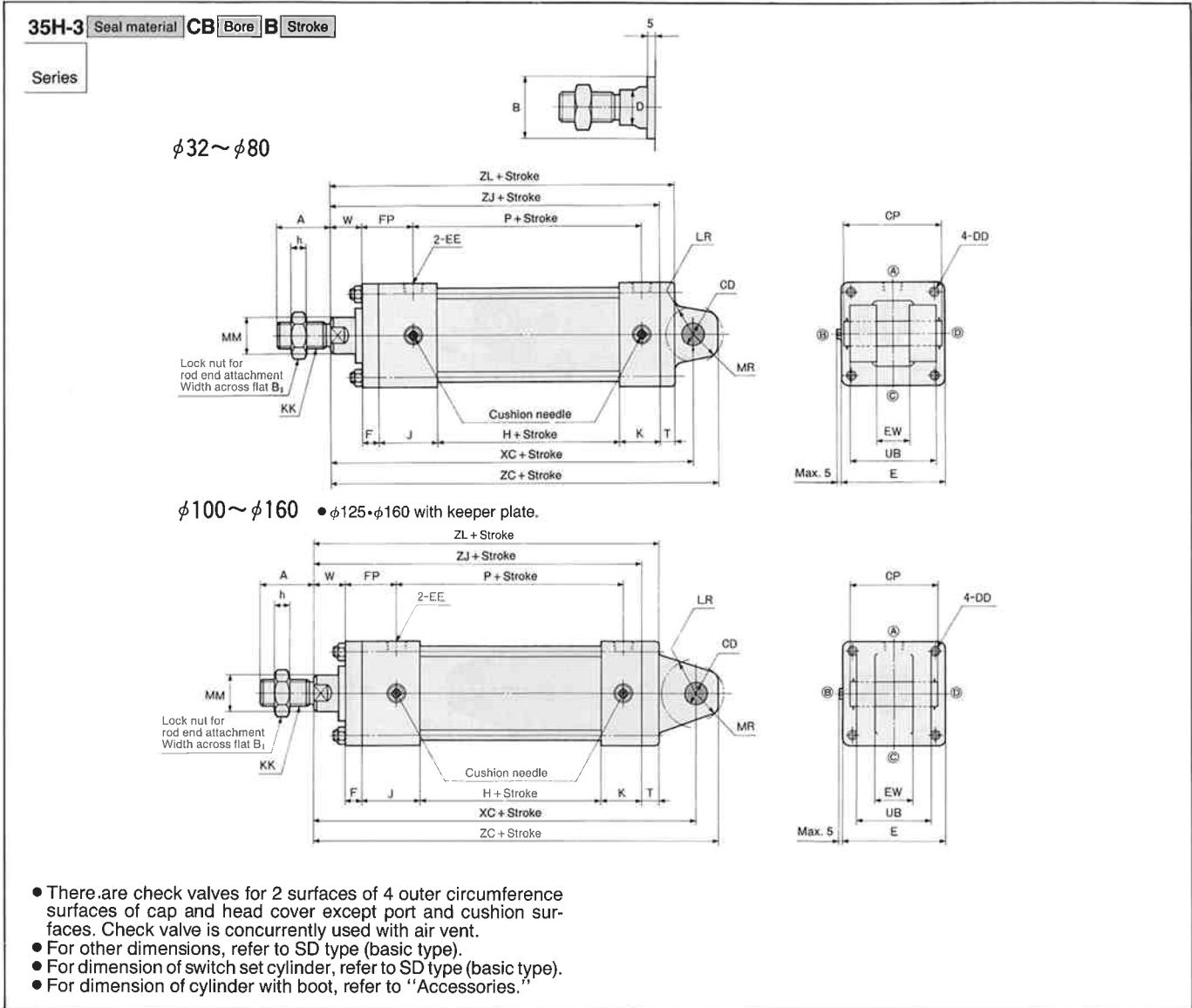

DIMENSIONAL TABLE

Bore	Symbol	A	B	B ₁	CD	CP	D	DD	E	EE	EW	F	FP	H	h	J
$\phi 32$		24	$\phi 30$	19	$\phi 12 \frac{H9}{f8}$	46	13	M6 × 1	□ 44	Rc ¹ / ₄	16 ^{+0.7} / _{+0.5}	10	34	30	7	38
$\phi 40$		24	$\phi 30$	19	$\phi 14 \frac{H9}{f8}$	58	13	M6 × 1	□ 50	Rc ³ / ₈	20 ^{+0.7} / _{+0.5}	10	34	30	7	38
$\phi 50$		36	$\phi 34$	24	$\phi 14 \frac{H9}{f8}$	66	19	M6 × 1	□ 62	Rc ³ / ₈	20 ^{+0.7} / _{+0.5}	10	34	30	11	38
$\phi 63$		36	$\phi 34$	24	$\phi 14 \frac{H9}{f8}$	66	19	M8 × 1.25	□ 76	Rc ³ / ₈	20 ^{+0.7} / _{+0.5}	10	34	33	11	38
$\phi 80$		48	$\phi 42$	32	$\phi 20 \frac{H9}{f8}$	78	24	M10 × 1.25	□ 94	Rc ¹ / ₂	32 ^{+0.7} / _{+0.5}	16	43	31	14	45
$\phi 100$		60	$\phi 50$	41	$\phi 25 \frac{H9}{f8}$	94	30	M12 × 1.5	□ 114	Rc ¹ / ₂	40 ^{+0.7} / _{+0.5}	16	43	31	17	45
$\phi 125$		84	$\phi 60$	60	$\phi 32 \frac{H9}{f8}$	105	41	M16 × 1.5	□ 138	Rc ¹ / ₂	45 ^{+0.7} / _{+0.5}	20	47	37	22	45
$\phi 160$		96	$\phi 72$	70	$\phi 36 \frac{H9}{f8}$	115	50	M20 × 1.5	□ 178	Rc ³ / ₄	50 ^{+0.7} / _{+0.5}	25	54	42	26	50

Bore	Symbol	K	KK	LR	MM	MR	P	T	UB	W	XC	ZC	ZJ	ZL
$\phi 32$		25	M12 × 1.25	R18	$\phi 16$	R15	58	8	32	15	137	150	118	126
$\phi 40$		25	M12 × 1.25	R18	$\phi 16$	R15	58	8	44	15	137	150	118	126
$\phi 50$		25	M18 × 1.5	R19	$\phi 22$	R17	58	8	52	15	137	152	118	126
$\phi 63$		25	M18 × 1.5	R19	$\phi 22$	R17	61	8	52	15	140	155	121	129
$\phi 80$		32	M24 × 2	R32	$\phi 28$	R23	67	11	64	19	175	196	143	154
$\phi 100$		32	M30 × 2	R32	$\phi 36$	R30	67	16	80	23	200	225	147	163
$\phi 125$		32	M42 × 2	R42	$\phi 45$	R36	73	19	90	25	226	258	159	178
$\phi 160$		38	M48 × 2	R45	$\phi 56$	R42	84	24	100	29	261	297	184	208

3.5MPa HYDRAULIC CYLINDER 35H-3

DIMENSIONAL DRAWINGS/TA TYPE (HEAD TRUNNION MOUNTING)

Unit: mm

35H-3 Seal material **TA** Bore **B** Stroke

Series

- For TA type, the position of cushion needle and air vent of head cover is structurally set at ©.
- In case of the interference of mounting bracket and switch of TA type, the switch mounting face shall be changed. (Upper face mounting)
- For other dimensions, refer to SD type (basic type).
- For dimension of switch set cylinder, refer to SD type (basic type).
- For dimension of cylinder with boot, refer to "Accessories."

DIMENSIONAL TABLE

Bore	Symbol	A	B	B ₁	BB	D	DD	E	EE	F	FP	H	h	J	K
φ32		24	φ30	19	7	13	M6 × 1	□ 44	Rc ¹ / ₄	10	34	30	7	38	25
φ40		24	φ30	19	7	13	M6 × 1	□ 50	Rc ³ / ₈	10	34	30	7	38	25
φ50		36	φ34	24	7	19	M6 × 1	□ 62	Rc ³ / ₈	10	34	30	11	38	25
φ63		36	φ34	24	9	19	M8 × 1.25	□ 76	Rc ³ / ₈	10	34	33	11	38	25
φ80		48	φ42	32	10	24	M10 × 1.25	□ 94	Rc ¹ / ₂	16	43	31	14	45	32
φ100		60	φ50	41	12	30	M12 × 1.5	□114	Rc ¹ / ₂	16	43	31	17	45	32
φ125		84	φ60	60	16	41	M16 × 1.5	□138	Rc ¹ / ₂	20	47	37	22	45	32
φ160		96	φ72	70	19	50	M20 × 1.5	□178	Rc ³ / ₄	25	54	42	26	50	38

Bore	Symbol	KK	MM	P	TD	TL	TM	TR	UM	W	XG	ZB	ZJ
φ32		M12 × 1.25	φ16	58	φ16e9	16	44	R1	76	15	44	125	118
φ40		M12 × 1.25	φ16	58	φ25e9	25	50	R1.6	100	15	44	125	118
φ50		M18 × 1.5	φ22	58	φ25e9	25	63	R1.6	113	15	44	125	118
φ63		M18 × 1.5	φ22	61	φ25e9	25	76	R1.6	126	15	44	130	121
φ80		M24 × 2	φ28	67	φ25e9	25	95	R1.6	145	19	57	153	143
φ100		M30 × 2	φ36	67	φ32e9	32	114	R2.5	178	23	61	159	147
φ125		M42 × 2	φ45	73	φ36e9	36	144	R2.5	216	25	67	175	159
φ160		M48 × 2	φ56	84	φ45e9	45	184	R3	274	29	79	203	184

35H-3 3.5MPa HYDRAULIC CYLINDER

DIMENSIONAL DRAWINGS/TC TYPE (INTERMEDIATE TRUNNION MOUNTING)

Unit: mm

35H-3 Seal material TC Bore B Stroke

Series

$\phi 32 \sim \phi 80$

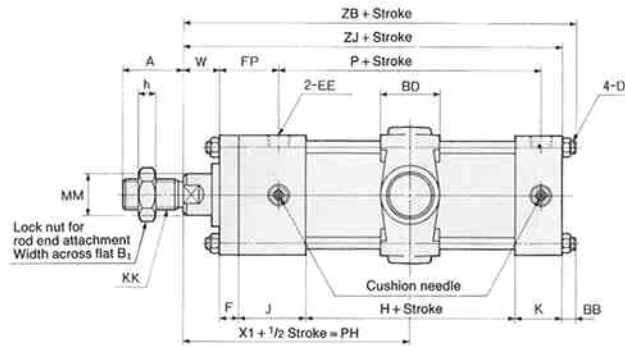
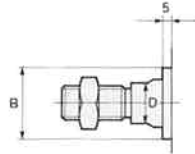
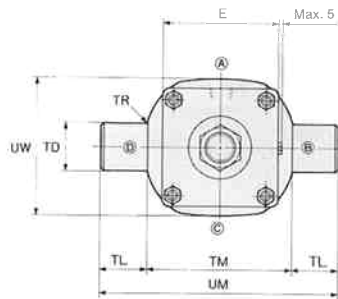

$\phi 100 \sim \phi 160$

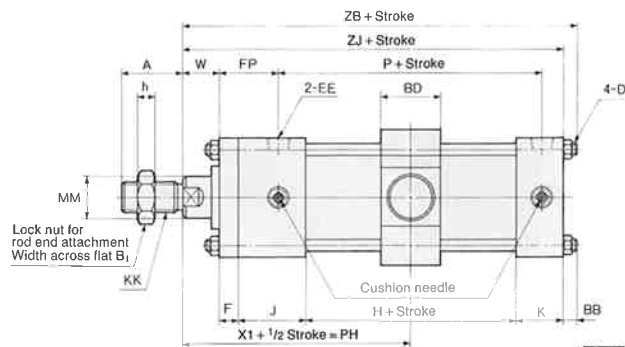
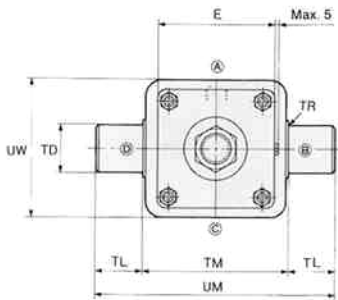

- There are check valves for 2 surfaces of 4 outer circumference surfaces of cap and head cover except port and cushion surfaces. Check valve is concurrently used with air vent.
- For other dimensions, refer to SD type (basic type).
- For dimension of switch set cylinder, refer to SD type (basic type).
- For dimension of cylinder with boot, refer to "Accessories."
- In case of boot, the PH dimension shall be instructed as the W dimension is changed.

MINIMUM PH DIMENSION OF SWITCH SET CYLINDER Unit: mm

Bore	Switch	YR-YS	WR-WS	SR-SS
$\phi 32$		133	163	143
$\phi 40$		133	163	143
$\phi 50$		133	163	143
$\phi 63$		136	166	146
$\phi 80$		148.5	179.5	163.5
$\phi 100$		155	191	170



- As shown in the above drawing, the minimum PH dimension of switch set cylinder is the dimension. When trunnion is moved to the rod side as much as possible in case that switch is set the rod side.

DIMENSIONAL TABLE

Bore	Symbol	A	B	B ₁	BB	BD	D	DD	E	EE	F	FP	H	h	J	K
$\phi 32$		24	$\phi 30$	19	7	30	13	M6 × 1	□ 44	Rc ¹ / ₄	10	34	30	7	38	25
$\phi 40$		24	$\phi 30$	19	7	30	13	M6 × 1	□ 50	Rc ³ / ₈	10	34	30	7	38	25
$\phi 50$		36	$\phi 34$	24	7	30	19	M6 × 1	□ 62	Rc ³ / ₈	10	34	30	11	38	25
$\phi 63$		36	$\phi 34$	24	9	30	19	M8 × 1.25	□ 76	Rc ³ / ₈	10	34	33	11	38	25
$\phi 80$		48	$\phi 42$	32	10	35	24	M10 × 1.25	□ 94	Rc ¹ / ₂	16	43	31	14	45	32
$\phi 100$		60	$\phi 50$	41	12	40	30	M12 × 1.5	□ 114	Rc ¹ / ₂	16	43	31	17	45	32
$\phi 125$		84	$\phi 60$	60	16	53	41	M16 × 1.5	□ 138	Rc ¹ / ₂	20	47	37	22	45	32
$\phi 160$		96	$\phi 72$	70	19	58	50	M20 × 1.5	□ 178	Rc ³ / ₄	25	54	42	26	50	38

Bore	Symbol	KK	MM	P	Min. PH	TD	TL	TM	TR	UM	UW	W	XI	ZB	ZJ
$\phi 32$		M12 × 1.25	$\phi 16$	58	78	$\phi 16e9$	16	55	R1	87	52	15	78	125	118
$\phi 40$		M12 × 1.25	$\phi 16$	58	78	$\phi 25e9$	25	63	R1.6	113	59	15	78	125	118
$\phi 50$		M18 × 1.5	$\phi 22$	58	78	$\phi 25e9$	25	76	R1.6	126	71	15	78	125	118
$\phi 63$		M18 × 1.5	$\phi 22$	61	78	$\phi 25e9$	25	88	R1.6	138	86	15	79.5	130	121
$\phi 80$		M24 × 2	$\phi 28$	67	98	$\phi 25e9$	25	114	R1.6	164	104	19	95.5	153	143
$\phi 100$		M30 × 2	$\phi 36$	67	104	$\phi 32e9$	32	140	R2.5	204	132	23	99.5	159	147
$\phi 125$		M42 × 2	$\phi 45$	73	117	$\phi 36e9$	36	166	R2.5	238	160	25	108.5	175	159
$\phi 160$		M48 × 2	$\phi 56$	84	133	$\phi 45e9$	45	214	R3	304	208	29	125	203	184

3.5MPa HYDRAULIC CYLINDER 35H-3

ACCESSORIES/BRACKET

Unit: mm

CB BRACKET

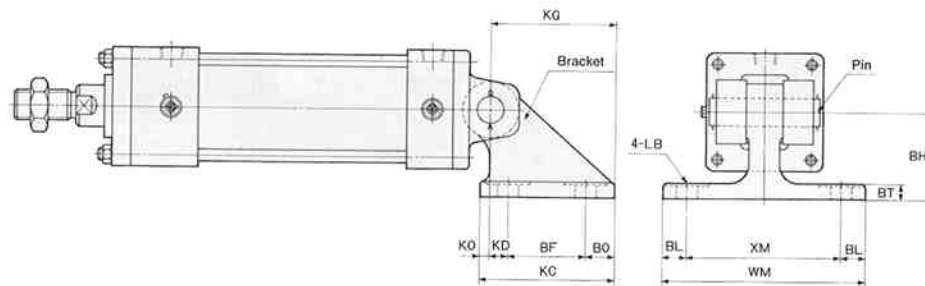

- For dimension of cylinder body, refer to CB type.

DIMENSIONAL TABLE

Bore	Symbol	Parts code	BF	BH	BL	BO	BT	KC	KD	KG	KO	LB	WM	XM
φ32		BCA-12-H	40	35	10	10	8	60	5	55	5	φ9	85	65
φ40		BCA-14-H	40	45	12.5	15	8	70	10	65	5	φ11	105	80
φ50														
φ63														
φ80		BCA-20-H	65	60	15	15	12	95	5	85	10	φ14	135	105
φ100		BCA-25-H	75	70	18.5	18.5	16	112	13.5	107	5	φ18	162	125
φ125		BCA-32-H	90	80	25	22.5	29	135	22.5	135	—	φ22	200	150
φ160		BCA-36-H	125	100	25	27.5	38	180	27.5	180	—	φ26	250	200

TA BRACKET

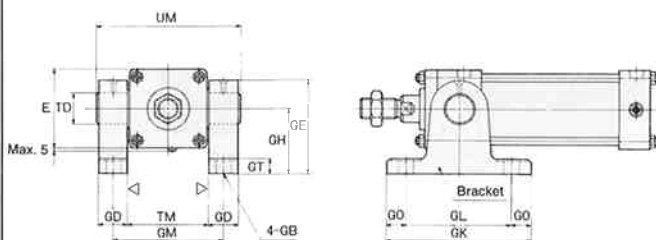

TC BRACKET

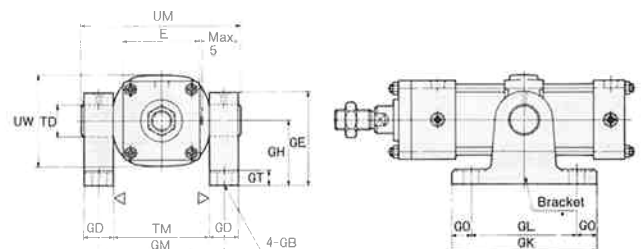

- TA-TC brackets shall be put in TA-TC attachments from the finishing side and the used.
- For dimension of cylinder body, refer to TA type.

- For dimension of cylinder body, refer to TC type.

DIMENSIONAL TABLE

Bore	Symbol	Parts code	E	GB	GD	GE	GH	GK	GL	GM		GO	GT	TD	TM		UM		UW
										TA type	TC type				TA type	TC type	TA type	TC type	
φ32		BTA-16-H	□ 44	φ9	15	56	40	80	60	59	70	10	12	φ16 ^{H9/e9}	44	55	76	87	52
φ40		BTA-25-H	□ 50	φ12	23	72	50	110	80	73	86	15	12	φ25 ^{H9/e9}	50	63	100	113	59
φ50	□ 62		φ12	23	72	50	110	80	86	99	15	12	φ25 ^{H9/e9}	63	76	113	126	71	
φ63	□ 76		φ12	23	72	50	110	80	99	111	15	12	φ25 ^{H9/e9}	76	88	126	138	86	
φ80		BTA-25-1-H	□ 94	φ14	23	92	70	120	85	118	137	17.5	14	φ25 ^{H9/e9}	95	114	145	164	104
φ100		BTA-32-H	□ 114	φ18	34	112	80	175	135	148	174	20	22	φ32 ^{H9/e9}	114	140	178	204	132
φ125		BTA-36-1-H	□ 138	φ22	36	128	85	205	160	180	202	22.5	26	φ36 ^{H9/e9}	144	166	216	238	160
φ160		BTA-45-1-H	□ 178	φ26	45	158	105	245	190	229	259	27.5	36	φ45 ^{H9/e9}	184	214	274	304	208

35H-3 3.5MPa HYDRAULIC CYLINDER

ACCESSORIES/ROD END ATTACHMENT

Unit: mm

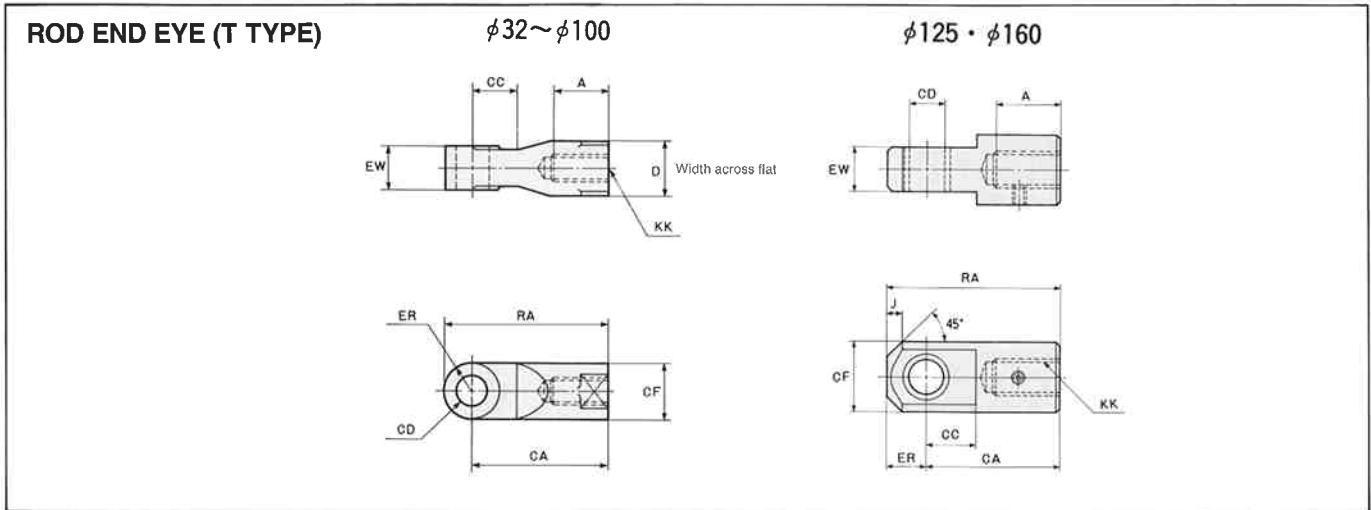

DIMENSIONAL TABLE

Bore	Symbol	Parts code	A	CA	CC	CD	CF	D	ER	EW	J	KK	RA
$\phi 32$		RTA-12-1-H	25	55	20	$\phi 12H9$	$\phi 24$	24	R12	$16_{-0.1}^0$	—	M12 \times 1.25	67
$\phi 40$		RTA-12-H	25	60	20	$\phi 14H9$	$\phi 24$	24	R12	$20_{-0.1}^0$	—	M12 \times 1.25	72
$\phi 50$		RTA-18-H	37	64	18	$\phi 14H9$	$\phi 28$	30	R14	$20_{-0.1}^0$	—	M18 \times 1.5	78
$\phi 63$													
$\phi 80$		RTA-24-H	49	100	30	$\phi 20H9$	$\phi 38$	41	R19	$32_{-0.1}^0$	—	M24 \times 2	119
$\phi 100$		RTA-30-H	61	110	37	$\phi 25H9$	$\phi 48$	50	R24	$40_{-0.1}^0$	—	M30 \times 2	134
$\phi 125$		RTA-42-2-H	67	132	40	$\phi 32H9$	$\phi 70$	—	32	$45_{-0.1}^0$	15	M42 \times 2	164
$\phi 160$		RTA-48-1-H	78	150	45	$\phi 36H9$	$\phi 79$	—	36	$50_{-0.1}^0$	19	M48 \times 2	186

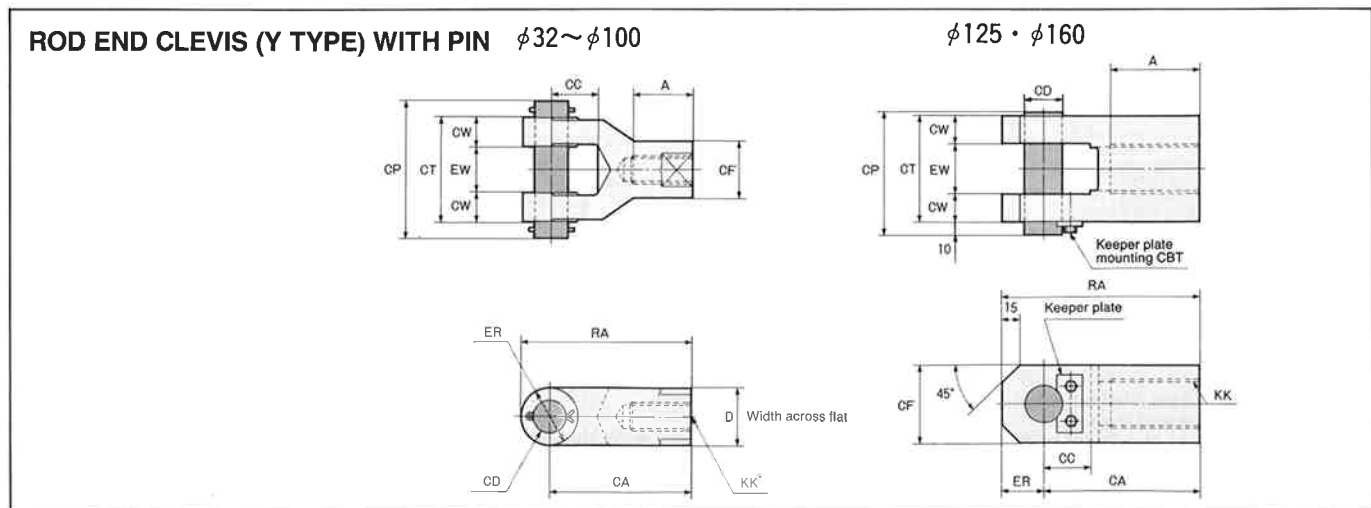

DIMENSIONAL TABLE

Bore	Symbol	Parts code	A	CA	CC	CD	CF	CP	CT	CW	D	ER	EW	KK	RA
$\phi 32$		RYA-12-2-H	25	55	20	$\phi 12_{+0.018}^{H9}$	$\phi 24$	46	32	8	24	R12	$16_{+0.5}^{+1.5}$	M12 \times 1.25	67
$\phi 40$		RYA-12-1-H	25	60	20	$\phi 14_{+0.018}^{H9}$	$\phi 24$	58	44	12	24	R12	$20_{+0.5}^{+1.5}$	M12 \times 1.25	72
$\phi 50$		RYA-18-H	37	64	18	$\phi 14_{+0.018}^{H9}$	$\phi 28$	58	44	12	30	R14	$20_{+0.5}^{+1.5}$	M18 \times 1.5	78
$\phi 63$															
$\phi 80$		RYA-24-H	49	100	28	$\phi 20_{+0.018}^{H9}$	$\phi 38$	78	64	16	41	R19	$32_{+0.5}^{+1.5}$	M24 \times 2	119
$\phi 100$		RYA-30-H	61	110	35	$\phi 25_{+0.018}^{H9}$	$\phi 48$	94	80	20	50	R24	$40_{+0.5}^{+1.5}$	M30 \times 2	134
$\phi 125$		RYA-42-2-H	75	132	40	$\phi 32_{+0.018}^{H9}$	65	105	90	22.5	—	35	$45_{+0.5}^{+1.5}$	M42 \times 2	167
$\phi 160$		RYA-48-H	86	150	45	$\phi 36_{+0.018}^{H9}$	70	115	100	25	—	40	$50_{+0.5}^{+1.5}$	M48 \times 2	190

3.5MPa HYDRAULIC CYLINDER 35H-3

ACCESSORIES/ROD END ATTACHMENTS

Unit: mm

F JOINT (F TYPE)

$\phi 32 \sim \phi 100$

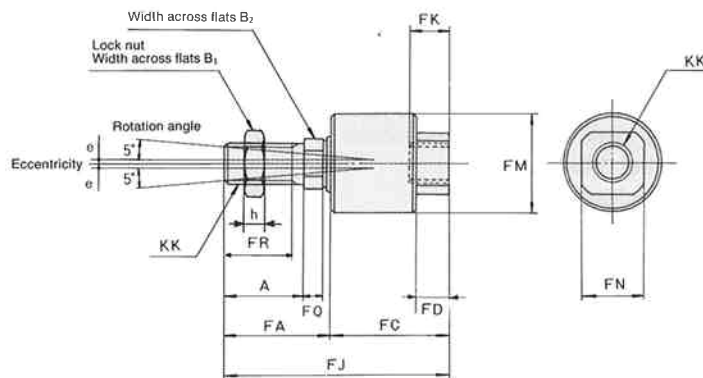

- Note) ● The insertion of F joint into socket shall not exceed the dimension of screw dia. (After insertion and thrust, it shall be turned back with one or two rotation to fix with lock nut.) The excessive insertion may cause the working inferiority.
● It shall not be used concurrently with CA•CB•TA•TB attachments.

DIMENSIONAL TABLE

Bore	Symbol	Parts code	A	B ₁	B ₂	e	FA	FC	FD	FJ	FK	FM	FN	FQ	FR	h	KK	
$\phi 32$		RFH-12	24	19	13	1	33	36.5	11	69.5	13.5	$\phi 32$	19	7	20.5	7	M12 × 1.25	
$\phi 40$																		
$\phi 50$		RFH-18	35	24	19	1.5	46	46	13	92	16	$\phi 40$	24	8	31	11	M18 × 1.5	
$\phi 63$																		
$\phi 80$		RFH-24-2	46	32	24	2.5	62	67	18	129	24	$\phi 64$	36	12	41	14	M24 × 2	
$\phi 100$		RFH-30-2	58	41	32	2.5	78	83	21	161	30	$\phi 76$	46	14	52	17	M30 × 2	

ACCESSORIES/WITH BOOT

Unit: mm

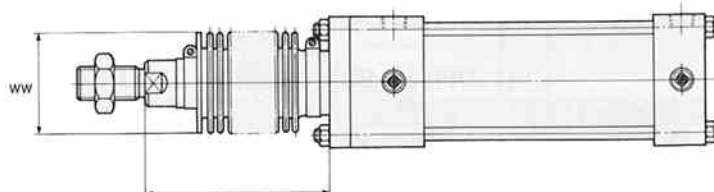

Nylon tarpaulin ($\phi 32 \sim \phi 63 \frac{1}{3} \text{ Stroke} + X$)
Chloroprene ($\phi 80 \sim \phi 160 \frac{1}{4} \text{ Stroke} + X$)
CONEX ($\phi 32 \sim \phi 63 \frac{1}{2.5} \text{ Stroke} + X$)
($\phi 80 \sim \phi 160 \frac{1}{3} \text{ Stroke} + X$)

- Count fractions under decimal.
- For other dimensions, refer to dimensional drawings for mounting style.

DIMENSIONAL TABLE

Bore	Symbol	WW	X
$\phi 32$		$\phi 36$	50
$\phi 40$		$\phi 40$	50
$\phi 50$		$\phi 45$	55
$\phi 63$		$\phi 45$	55
$\phi 80$		$\phi 60$	65
$\phi 100$		$\phi 71$	65
$\phi 125$		$\phi 80$	65
$\phi 160$		$\phi 100$	70

Material	Standard		Semi-standard
	Nylon tarpaulin	Chloroprene	Conex
Heat-proof	80°C	130°C	200°C

Note) It shall be noted that rod gland differs from fundamental type cylinder in case of with boots. For heat proof, the heat proof temperature of boots is indicated. CONEX is the registered trade mark of Teijin, Ltd. Boots are mounted to cylinder for delivery.

ROD END LOCK NUT PARTS CODE

Bore	Code
$\phi 32$	LNA-12F-H
$\phi 40$	LNA-12F-H
$\phi 50$	LNA-18F-H
$\phi 63$	LNA-18F-H
$\phi 80$	LNA-24F-H
$\phi 100$	LNA-30F-H
$\phi 125$	LNA-42F-H
$\phi 160$	LNA-48F-H