

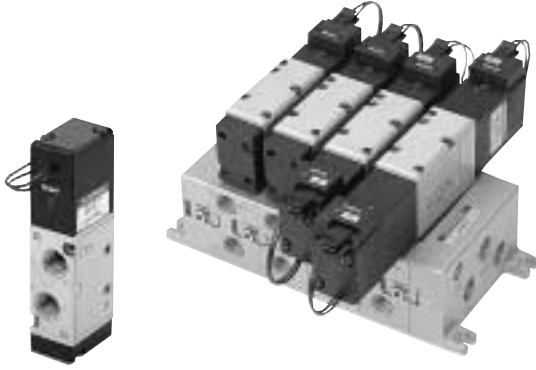

CAD drawing data catalog
is available.



KOGANEI

VALVES GENERAL CATALOG

SOLENOID VALVES 240 SERIES INDEX

Features	631
Basic Models and Configuration	633
Specifications	635
Solenoid Valve, Air-piloted Valve Order Codes	637
Manifold Order Codes	638
Manifold for Serial Transmission System Order Codes	639
Operating Principles and Major Parts	640
Dimensions of Solenoid Valve	641
Dimensions of Manifold	646
Dimensions of Serial Transmission System	649
Made to Order	651
Handling Instructions and Precautions	656

SOLENOID VALVES 240 SERIES



Caution

Before use, be sure to read the "Safety Precautions" on p. 31.

Multiple Application Systems for

240 SERIES SOLENOID VALVES

Koganei, which has always supplied products compatible with customer needs, has recently developed the 240 series valves in response to worksite requirements. The 240 series valves are suitable for operating mid-sized cylinders of bore sizes 63mm [2.480in.] to 100mm [3.937in.], and offer every required function. In addition to 5-port 2-position types, closed center and exhaust center 3-position valves are included in the product range. Serial transmission modules, which are compatible with connecting directly to various manufacturers' PCs, are also included in the product variations. The series realizes optimum system design, offering space saving as well as reducing wiring and piping work.

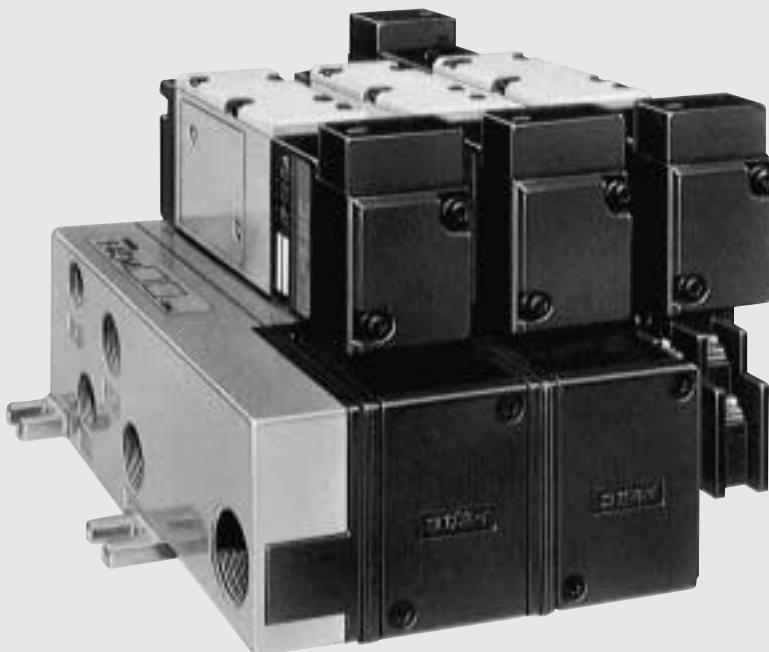

One-touch connect/disconnect **Plug-In Connector for Wiring Connections**

● A plug-in connector is available for wiring connections between the solenoid valve and sub-base, as well as between the solenoid valve and manifold, so that you can remove the solenoid valve without disturbing the wiring portion.

Easy to increase or decrease the number of manifold units **Stacking Type Manifold**

● You can increase or decrease the number of manifold units easily due to the individual manifold construction using each solenoid valve mounted unit.
● You can stock manifold bases as single units, thereby offering you a reduction in stocking costs.

Easy Operation at Worksite.

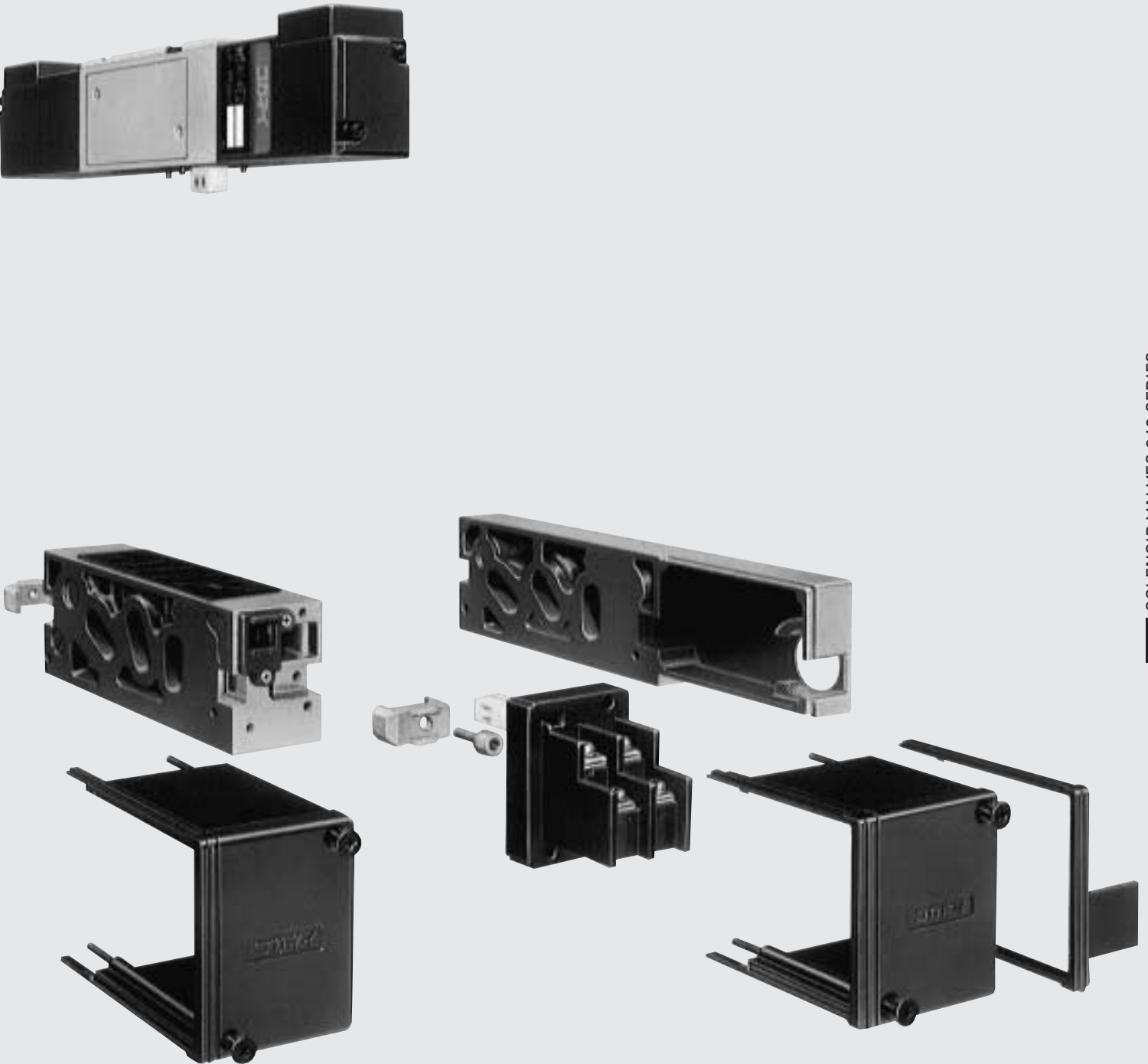

SOLENOID VALVES 240 SERIES

You can select port direction and supply pressure according to your requirements.









The Bottom Ports on the Manifold Increase Versatility.

- You can use the bottom ports on the manifold for piping.
- By using the port isolator between manifold station ports, you can supply multiple pressures on 1 manifold assembly.

Compatible with control by sequencers and PCs Low Power Consumption and Highly Reliable Solenoid

- By using a low power consumption solenoid, 1.6W at DC24V and 65mA, improved reliability and low heat generation are achieved.
- A serial transmission system, which offers distributed system control from a PC, is available and offers a cost reduction when considering the complete pneumatic control system.

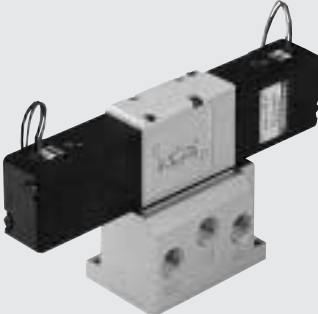
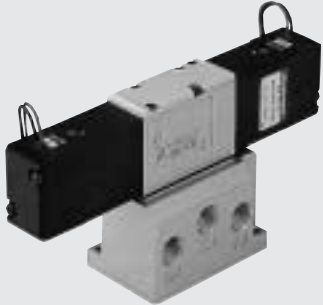
Single unit

		5-port			
Direct piping		2-position		3-position	
		Single solenoid	Double solenoid	Closed center	Exhaust center
					
		240-4E1	240-4E2	243-4E2	243-4E2-13
Standard sub-base piping		2-position		3-position	
		Single solenoid	Double solenoid	Closed center	Exhaust center
					
		A240-4E1-25 A240-4E1-27	A240-4E2-25 A240-4E2-27	A243-4E2-25 A243-4E2-27	A243-4E2-13-25 A243-4E2-13-27
Plug-in sub-base piping		2-position		3-position	
		Single solenoid	Double solenoid	Closed center	Exhaust center
					
		W240-4E1-26 W240-4E1-28	W240-4E2-26 W240-4E2-28	W243-4E2	W243-4E2-13
			These are dedicated valves for the manifold.		

Manifold

Manifold for mounting 5-port valves

240M□F—F type 1 (P), 3 (R2), 5 (R1) manifold

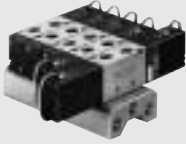

240M□A—A type (all ports) manifold

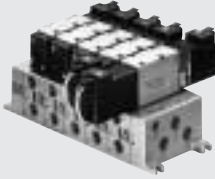

240M□B—B type (bottom ported all ports) manifold

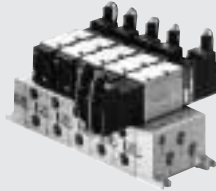

240M□AW—AW type (plug-in and all ports) manifold

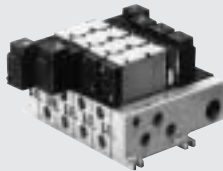

240M□BW—BW type (plug-in and bottom ported all ports) manifold

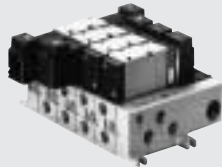

240M□AS□—AW type (side piping and compatible with serial transmission module) manifold

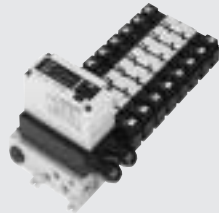

240M□BS□—BW type (bottom piping and compatible with serial transmission module) manifold

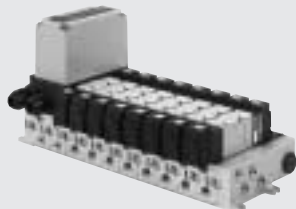

SOLENOID VALVES

240 SERIES

Specifications

Basic model	Solenoid specifications			
	Single solenoid	Double solenoid	3-position double solenoid	
Item	For direct piping For F type manifold	240-4E1	240-4E2	243-4E2
	For standard type sub-base For A type, B type manifolds	A240-4E1	A240-4E2	A243-4E2
	For pug-in type sub-base For AW, BW type manifolds	W240-4E1	W240-4E2	W243-4E2
Media	Air			
Operation type	Internal pilot type			
Number of positions, Number of ports	2 positions, 5 ports		3 positions, 5 ports	
Valve function	—		Closed center (standard) or Exhaust center (optional)	
Effective area [Cv]	mm ²	16 [0.88] (11.3 [0.62]) ^{Note 1}	15 [0.83] (11 [0.61]) ^{Note 1}	
Port size	P, A, B, R: Rc1/4 R: Rc1/8 (P, A, B, R: Rc1/4 PR: Rc1/8) ^{Note 2}			
Lubrication	Not required			
Operating pressure range MPa [kgf/cm ²] [psi.]	0.17~0.7 {1.7~7.1} [25~102]			
Proof pressure MPa [kgf/cm ²] [psi.]	1.05 {10.7} [152]			
Response time ms	DC24V	25/35	20/20	25/55
ON/OFF	AC100V, AC200V	25/25	20/20	25/45
Operating temperature range (atmosphere and media) °C [°F]	5~50 [41~122]			
Shock resistance m/s ² [G]	Lateral direction	1373.0 [140.0]		
	Axial direction	451.1 [46.0]	264.8 [27.0]	588.4 [60.0]
Mounting direction	Any			
Maximum operating frequency Hz	5			
Minimum time to energize ms	—		50	—
Mass g [oz.]	160 [5.64] (350 [12.35]) ^{Note 3} 400 [14.11] ^{Note 4}	230 [8.11] (420 [14.81]) ^{Note 3} 470 [16.58] ^{Note 4}	260 [9.17] (450 [15.87]) ^{Note 3} 500 [17.64] ^{Note 4}	

Notes: 1. Effective area for A240-4E□, W240-4E□. 2. Port size of sub-base.
3. Mass of A240-4E□ with sub-base. 4. Mass of W240-4E□ with sub-base.

Remarks: For optional specifications and order codes, see p.637~639.

Solenoid Specifications

Rated voltage		AC100V	AC200V	DC24V	
Item	Type	Shading type		Flywheel diode incorporated for surge suppression	
Operating voltage range	V	90~132 (100 ⁺³² / ₋₁₀ %)		180~264 (200 ⁺³² / ₋₁₀ %)	
Current (when rated voltage is applied)	Frequency Hz	50	60	50	60
	Starting mA (r.m.s.)	34	32	17	16
Allowable leakage current	Energizing mA (r.m.s.)	22	20	11	10
	mA	4		2	
Insulation resistance	MΩ	Over 100			
Wiring type	Standard type	Standard			
	Optional	Grommet type: 300mm [11.8in.] Plug connector type Straight connector -PS: 300mm [11.8in.]※ -PSN: Without lead wire (connector, contacts included) L connector -PL: 300mm [11.8in.]※ -PLN: Without lead wire (connector, contacts included) ※1000 [39in.], 3000mm [118in.] also available as options. Specify separately when ordering -1L: 1000, -3L: 3000.			
Surge suppression	Plug-in type	Terminal type (Sub-base comes with conduit cover, and manifold with terminal cover)			
	Color of lead wire	Yellow	White	Red (+), Black (-)	
Color of LED indicator (optional)	Yellow	Green	Red		

Manifold Specifications and Port Size

Manifold model	Specifications	Port size		Applicable valve model	Remarks
240M□F	1(P), 3(R2), 5(R1) manifold piping 4(A), 2(B) valve piping	1 (P)	Rc1/4	240-4E1 240-4E2 243-4E2	Piping not allowed on the PR port.
		4 (A), 2 (B)			
		3 (R2), 5 (R1)			
240M□A	All port manifold piping	1 (P)	Rc1/4	A240-4E1 A240-4E2 A243-4E2	
		4 (A), 2 (B)			
		3 (R2), 5 (R1)			
240M□AW	All port manifold piping plug-in type	PR	Rc1/8	W240-4E1 W240-4E2 W243-4E2	
		1 (P)			
		4 (A), 2 (B) 3 (R2), 5 (R1)			
240M□B	All port manifold piping bottom ported	End plate and side port	Rc1/4	A240-4E1 A240-4E2 A243-4E2	By using port isolators, the 1(P), 4(A), 2(B), 3(R2) and 5(R1) ports can be selected on either the end plate, side piping or bottom piping (the PR port is available only on the end plate).
		1 (P)			
		4 (A), 2 (B) 3 (R2), 5 (R1)			
		Bottom port	Rc1/8		
		1 (P)			
		4 (A), 2 (B) 3 (R2), 5 (R1)			
240M□BW	All port manifold piping bottom ported plug-in type	End plate and side port	Rc1/4	W240-4E1 W240-4E2 W243-4E2	By using port isolators, the 1(P), 4(A), 2(B), 3(R2) and 5(R1) ports can be selected on either the end plate, side piping or bottom piping (the PR port is available only on the end plate).
		1 (P)			
		4 (A), 2 (B) 3 (R2), 5 (R1)			
		Bottom port	Rc1/8		
		1 (P)			
		4 (A), 2 (B) 3 (R2), 5 (R1)			

For order codes, see p.637~639.

Manifold Mass

Manifold model	Mass calculation of each unit (n=number of units)	Mounting valve							Block-off plate		
		240-4E1	240-4E2	243-4E2	A240-4E1	A240-4E2	A243-4E2	W240-4E1		W240-4E2	W243-4E2
240M□F	(69×n)+69 [(2.43×n)+2.43]	160 [5.64]	230 [8.11]	260 [9.17]	—	—	—	—	—	—	30 [1.06]
240M□A	(167×n)+217 [(5.89×n)+7.65]	—	—	—	160 [5.64]	230 [8.11]	260 [9.17]	—	—	—	
240M□AW	(199×n)+270 [(7.02×n)+9.52]	—	—	—	—	—	—	160 [5.64]	230 [8.11]	260 [9.17]	
240M□B	(167×n)+217 [(5.89×n)+7.65]	—	—	—	160 [5.64]	230 [8.11]	260 [9.17]	—	—	—	
240M□BW	(199×n)+270 [(7.02×n)+9.52]	—	—	—	—	—	—	160 [5.64]	230 [8.11]	260 [9.17]	

Calculation example: The mass of 240M10F stn. 1~5-240-4E1

stn. 6~10-240-4E2, (69×10)+69+(160×5)+(230×5)=2709g [95.56oz.].

240-4E1 Flow rate

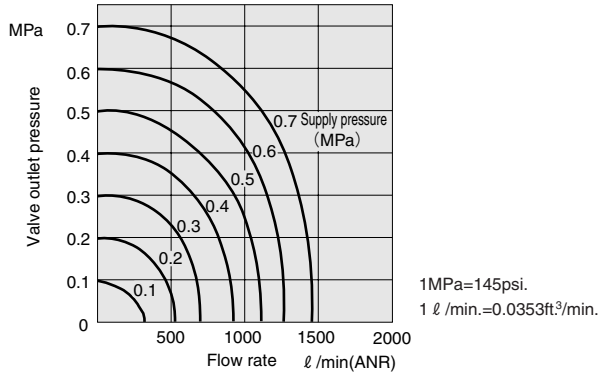

A240-4E1-25 Flow rate

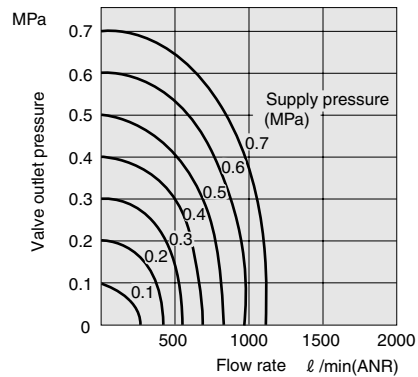

Maximum operating speed

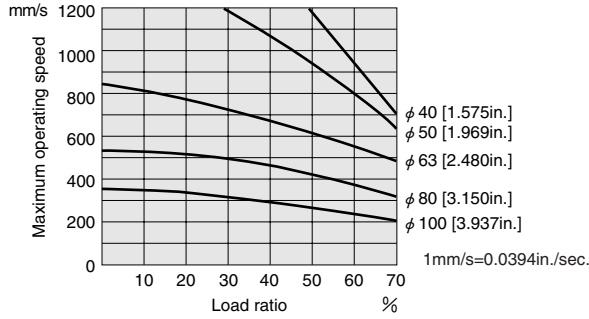

Maximum operating speed

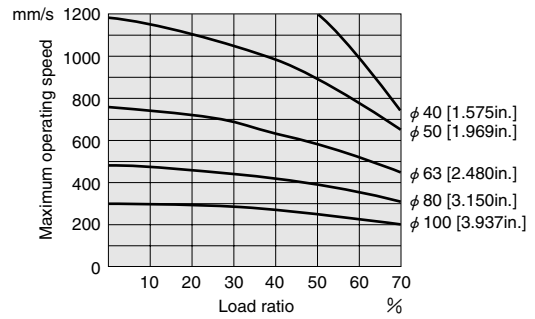

Delay time

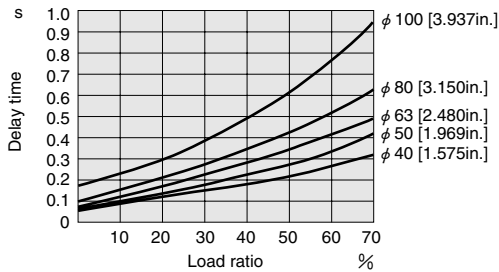

Delay time

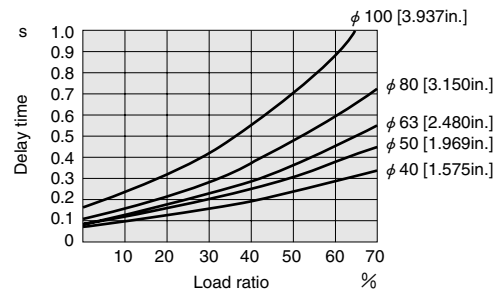

Measurement conditions

- Air pressure: 0.5MPa {5.1kgf/cm²} [73psi.]
- Piping inner diameter and length: φ 7.5×1000mm [39in.]
- Fitting: Quick fitting TS10-02
- Load ratio = $\frac{\text{Load}}{\text{Cylinder theoretical thrust}}$ (%)
- Cylinder stroke: 300mm [11.8in.]

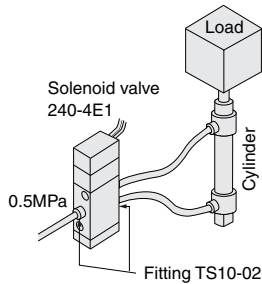

Measurement conditions

- Air pressure: 0.5MPa {5.1kgf/cm²} [73psi.]
- Piping inner diameter and length: φ 7.5×1000mm [39in.]
- Fitting: Quick fitting TS10-02
- Load ratio = $\frac{\text{Load}}{\text{Cylinder theoretical thrust}}$ (%)
- Cylinder stroke: 300mm [11.8in.]

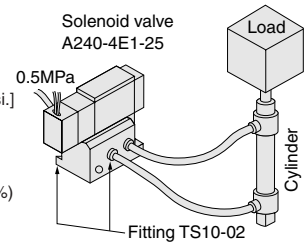



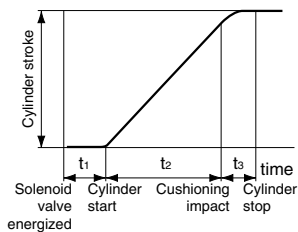





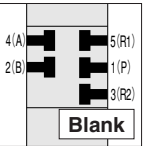
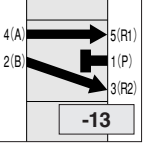





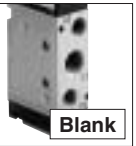

How to obtain cylinder speed

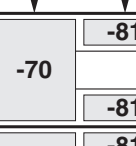

To obtain the time required for the cylinder to complete 1 stroke, add cylinder's delay time t_1 (time between energizing of the solenoid valve and actual starting of the cylinder), to the cylinder's max. speed operating time t_2 .
When a cushion is used, add the cushioning time t_3 , to the above calculations. The standard cushioning time t_3 is approximately 0.2 seconds.

240 Series Solenoid Valve, Air-piloted Valve Order Codes

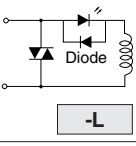
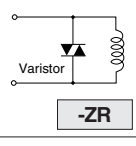
3-position valve	Mounting base	Sub-base	Speed controller	Manual override	Wiring type (standard type)	Wiring type (plug-in type)
Valve function Closed center  Exhaust center 	Without mounting base  With mounting base 	Side piping standard type  Side piping plug-in type  Side and bottom piping standard type  Side and bottom piping plug-in type 	Without speed controller  With speed controller 	Non-locking type  Standard  Locking type 	Grommet type  Standard  Straight connector with LED indicator  With lead wire L connector with LED indicator  With lead wire DIN connector 	Standard plug-in  With LED indicator  With built-in varistor for surge suppression 

	Basic model						Voltage
Direct piping	Single solenoid	240-4E1	-21	-70	-81	-ZR, -39	DC24V
	2-position double solenoid	240-4E2		-70		-PS-L	AC100V
	3-position double solenoid	243-4E2	-13		-81	-PSN-L, -PL-L, -PLN-L	AC200V
Standard sub-base piping	Single solenoid	A240-4E1		-25	-70 ^{Note 1}	-81	DC24V
	2-position double solenoid	A240-4E2		-27		-PS-L	AC100V
	3-position double solenoid	A243-4E2	-13		-81	-PSN-L, -PL-L, -PLN-L	AC200V
Plug-in sub-base piping	Single solenoid	W240-4E1		-26	-70 ^{Note 1}	-81	-L
	2-position double solenoid	W240-4E2		-28			DC24V
	3-position double solenoid	W243-4E2 ^{Note 2}	-13		-81	-ZR	AC100V
Direct piping air-piloted valves (made to order)	Single pilot	240-4A		-21	-70		AC200V
	Double pilot	240-4A2					
Sub-base piping air-piloted valves (made to order)	Single pilot	A240-4A		-25	-70 ^{Note 1}		
	Double pilot	A240-4A2		-27			



Notes: 1. Attached to the sub-base.
 2. Because the long valve body interferes with the connector, no sub-base is set in the order codes.

● When ordering the non-ion specification, enter **-NCU** after the basic model code.

- Not available for 240-4E2, A240-4E2, W240-4E2.
- **-ZR**: Varistor for surge suppression is available for AC100V and AC200V only (flywheel diode for surge suppression is standard equipment for DC24V) and a varistor for surge suppression is built into AC100V and AC200V with LED indicator.
- **Color of LED indicator** AC100V: yellow, AC200V: green, DC24V: red
- **-PS-L, -PL-L**: Lead wire length can be selected.

When ordering, specify **-1L**: 1000, **-3L**: 3000. Lead wire length: mm [in.] 300 [11.8]—Standard 1000 [39], 3000 [118]—Optional

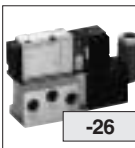
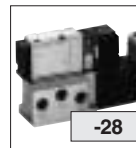
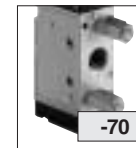
Options

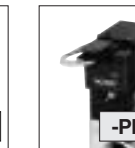
Mounting base	Plug-in type sub-base	Speed controller	Manual override	Straight connector	L connector	DIN connector
 -21	 -26	 -28	 -70	 -81	 -PS-L	 -PL-L
	● Side piping type	● Side and bottom piping type	● Attached to the sub-base in the case of sub-base type.	● Locking type	● With lead wire and LED indicator Surge suppression	● With lead wire and LED indicator Surge suppression

240 Series Manifold Order Codes

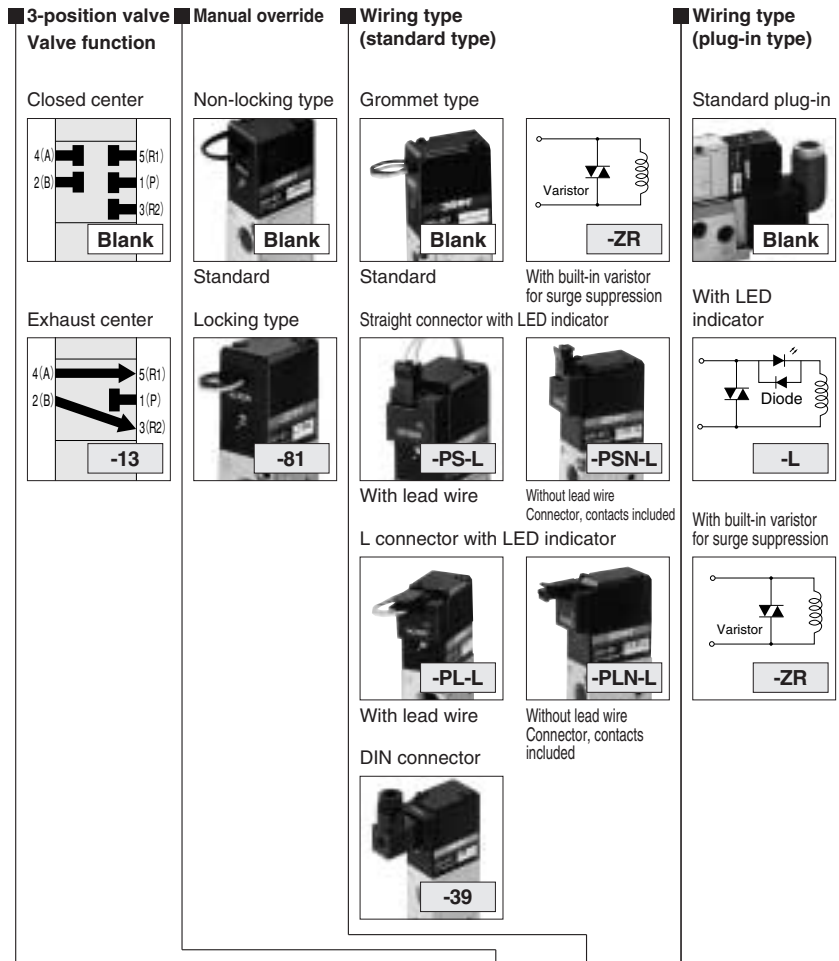

SOLENOID VALVES 240 SERIES

Manifold model Number of units		Station	Basic model	Wiring type (standard type)	Wiring type (plug-in type)	Voltage	
Manifold for mounting 5-port valves	240M	F	stn. □	-240-4E1	-81	-ZR, -39	DC24V AC100V AC200V
			□	-240-4E2		-PS-L	
			stn. □	-243-4E2	-13	-81	
		A B	stn. □	-A240-4E1	-81	-ZR, -39	DC24V AC100V AC200V
			□	-A240-4E2		-PS-L	
			stn. □	-A243-4E2	-13	-81	
	AW BW	stn. □	-W240-4E1	-81	-L	DC24V AC100V AC200V	
		□	-W240-4E2		-ZR		
		stn. □	-W243-4E2	-13	-81		
Manifold for mounting 5-port valves (made to order)	240M	F	stn. □	-240-4A			
			□	-240-4A2			
		A B	stn. □	-A240-4A			
			□	-A240-4A2			

● Valve mounting location from the left-hand side when facing the 4(A), 2(B) ports.

- Specify the valve model for each station.
- Enter -BP when closing a station with a block-off plate without mounting a valve.
- When ordering the non-ion specification, enter -NCU after the basic model code.

Made to order

Air-piloted valves
240 series



- 5-port, 2-position
- Single pilot
- Double pilot

Symbols

Single solenoid

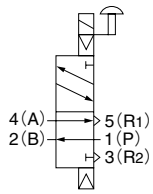

2-position double solenoid

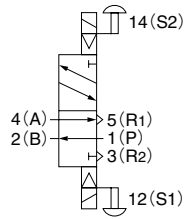

3-position double solenoid

Closed center

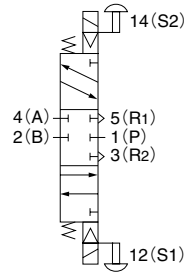

Exhaust center

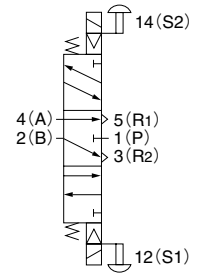

Operating Principles and Major Parts

Major Parts and Materials

Parts	Materials
Body	Aluminum alloy (treated with chromic acid)
Stem	Aluminum alloy (anodized)
Lip seal	Synthetic rubber
Flapper	Synthetic rubber
Mounting base	Mild steel (zinc plated)
Sub-base	Aluminum alloy (anodized)
Plunger	Magnetic stainless steel
Column	Steel

Remark: Materials that generate copper ions are not used for the non-ion specification.

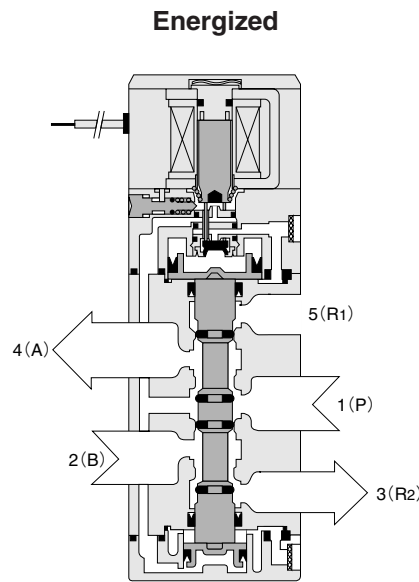
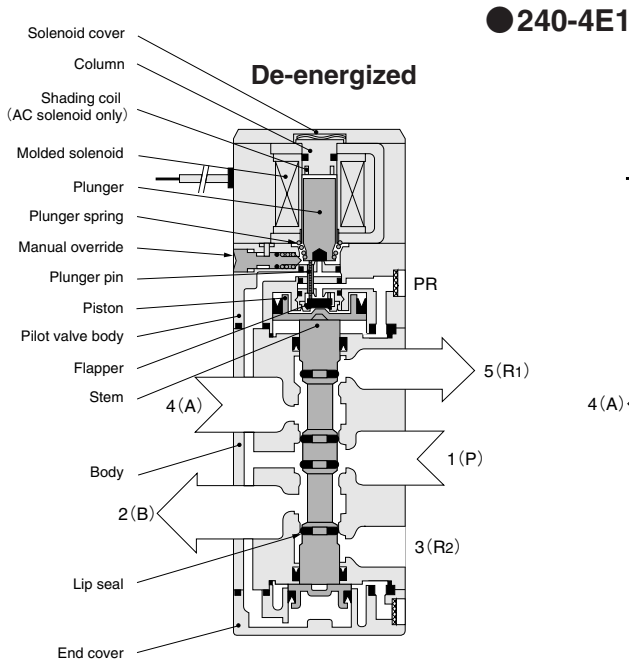

● 240-4E2
(De-energized condition after energizing solenoid 12 (S1))

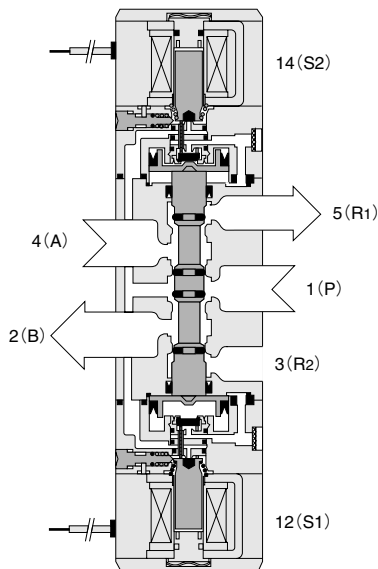

● 243-4E2
(Both solenoid 12 (S1) and 14 (S2) are de-energized.)

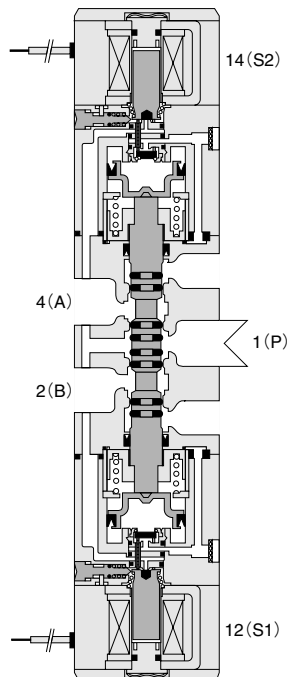

● 243-4E2-13
(Both solenoid 12 (S1) and 14 (S2) are de-energized.)

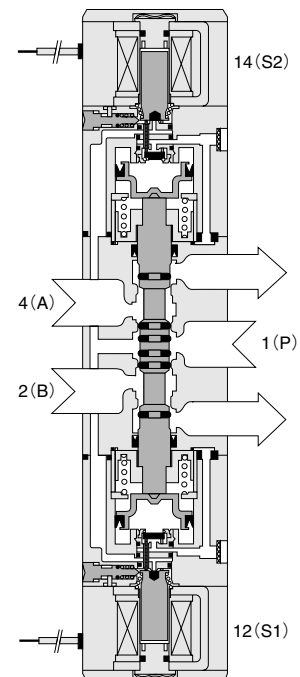

Dimensions of Solenoid Valve (mm)

●240-4E1

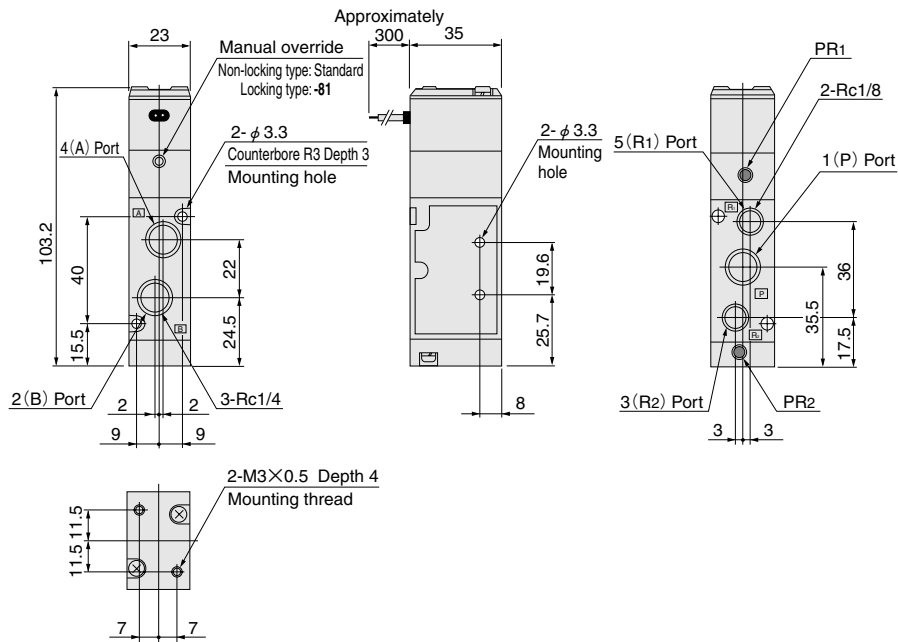

●240-4E2

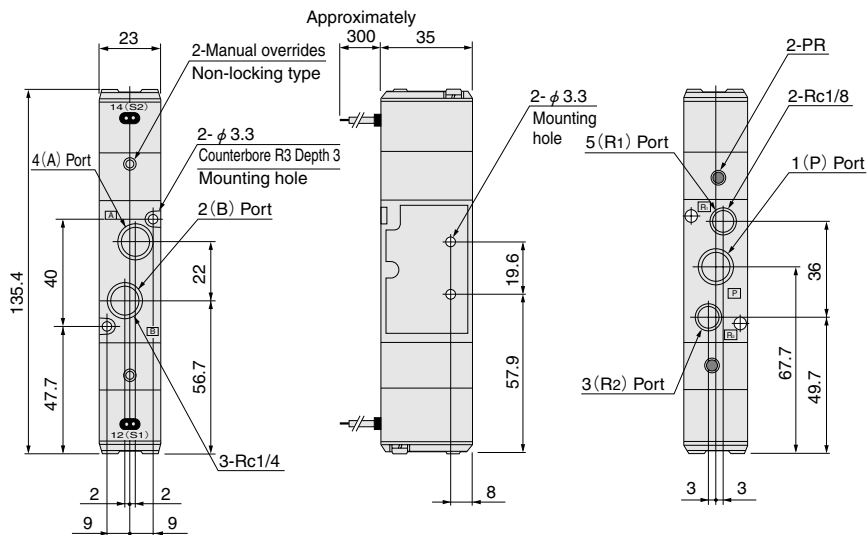

● 243-4E2

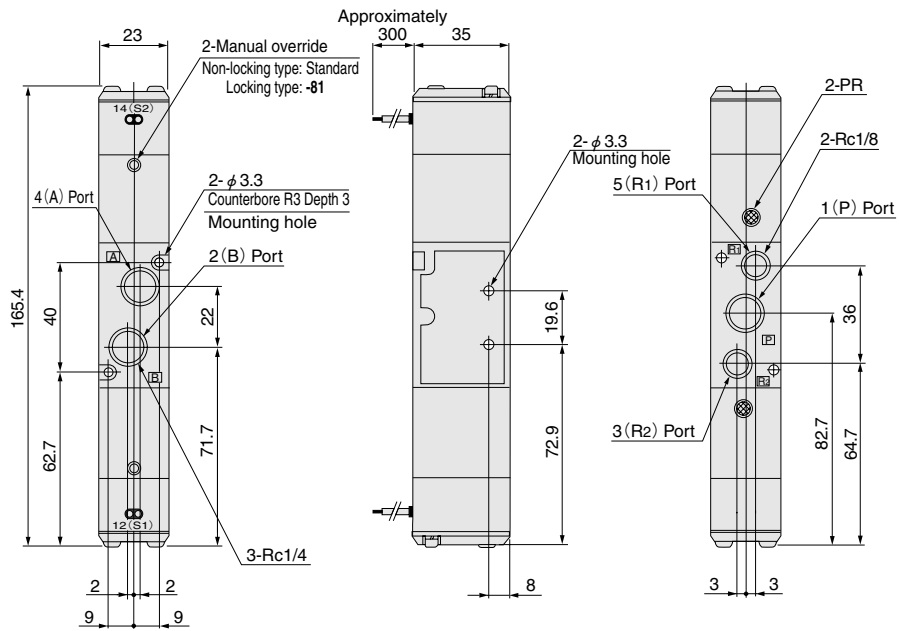

Options

● Mounting base: -21



240SC

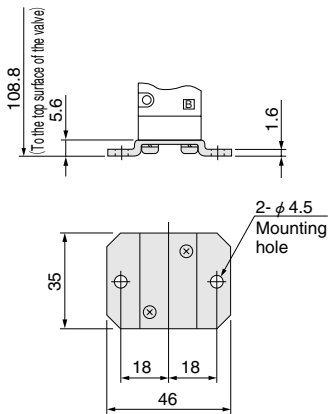

● Straight connector with LED indicator: -PS(N)-L



240SOL

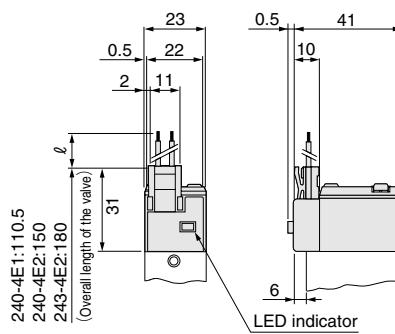

● With built-in varistor for surge suppression: -ZR

Dimensions are the same as the standard product.

● Speed controller: -70



240SC

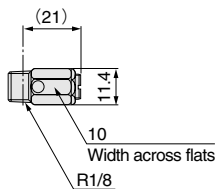

● L connector with LED indicator: -PL(N)-L



240SOL

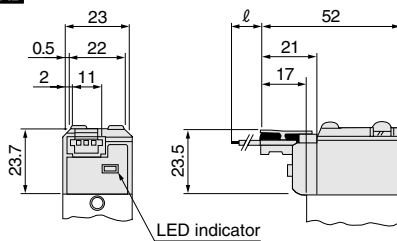

● DIN connector: -39



240SOL

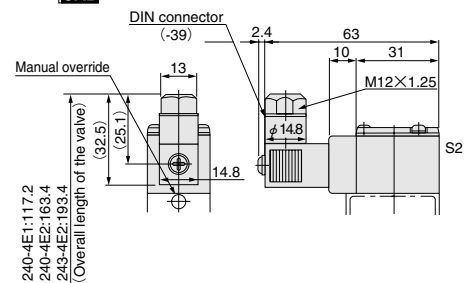

Dimensions of Solenoid Valve (mm)

- A240-4E1-25
- A240-4E1-27

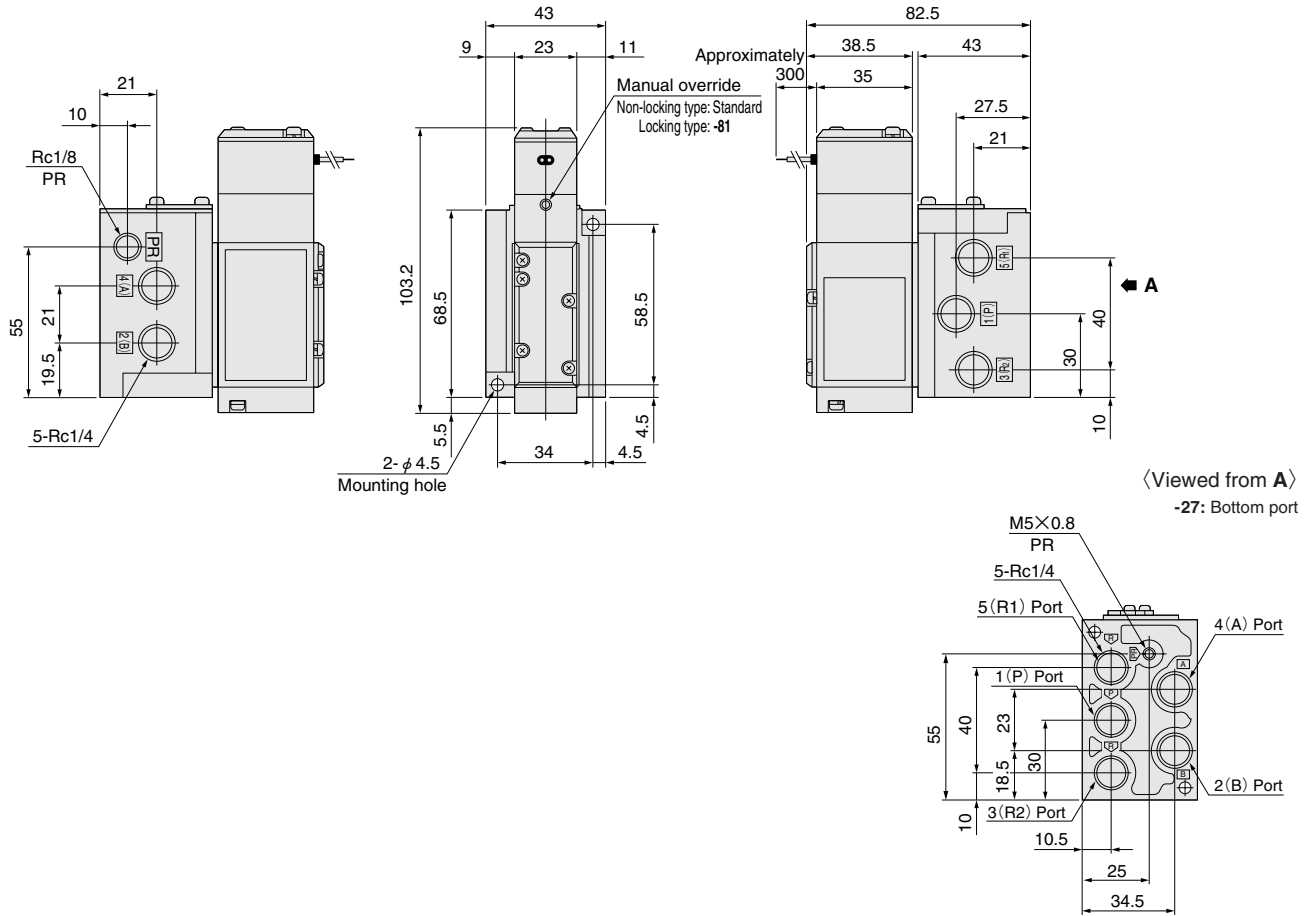

- A240-4E2-25
- A240-4E2-27

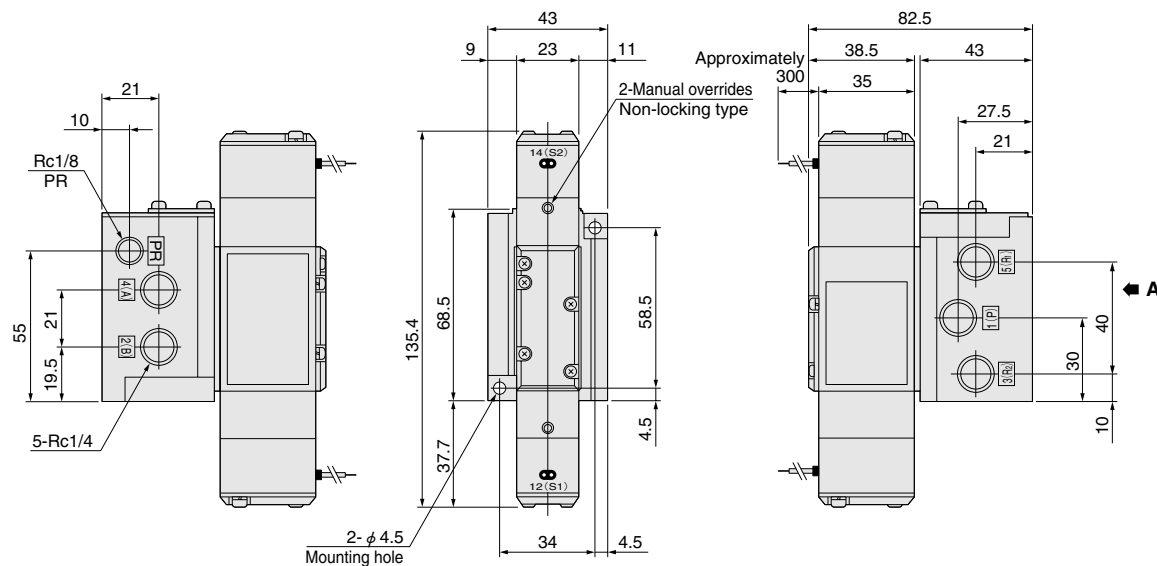

●A243-4E2-25
●A243-4E2-27

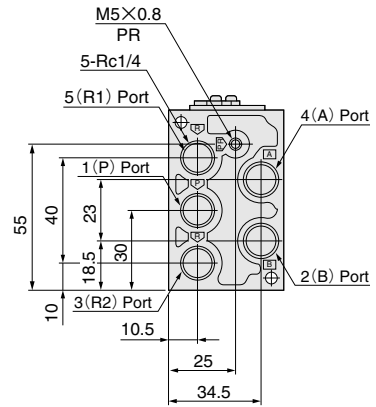
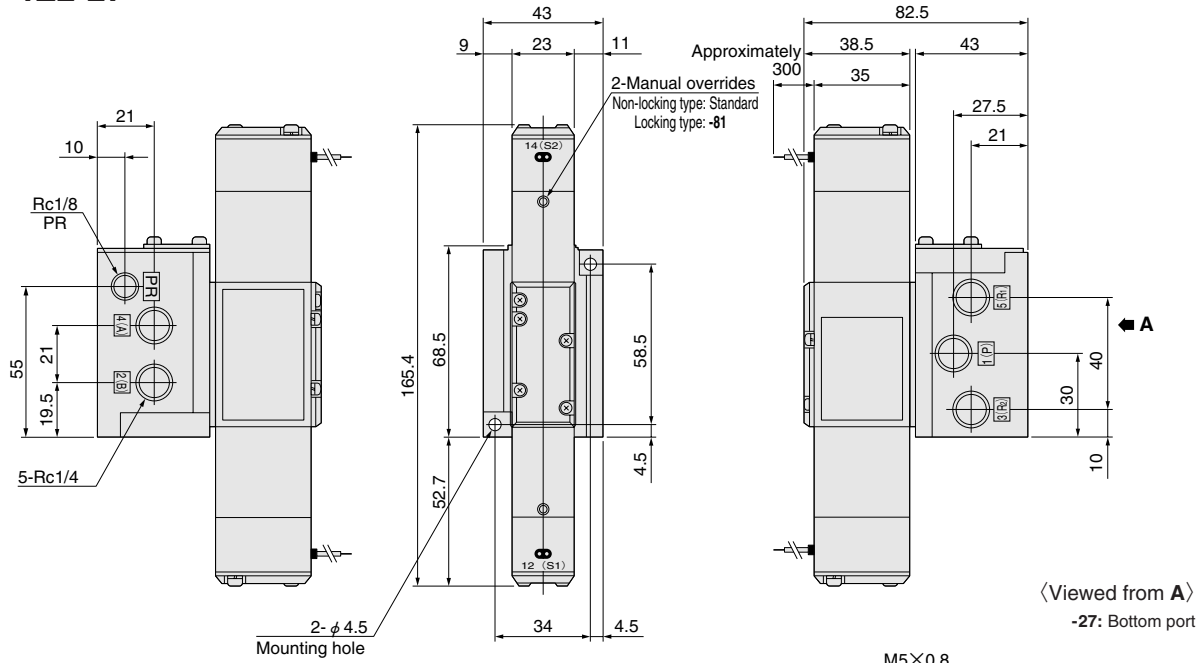

Options

●Speed controller : -70

 240SC

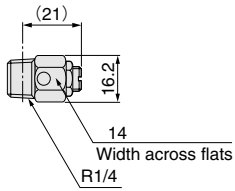

●Dimensions for the built-in varistor for surge suppression are the same as for the standard product.

●DIN connector: -39

 240SOL

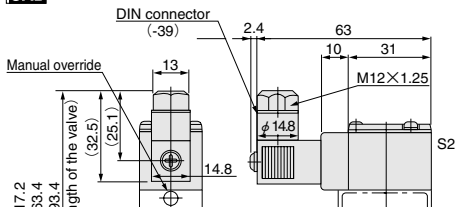

240-4E1:117.2
240-4E2:163.4
243-4E2:193.4
(Overall length of the valve)

●Straight connector with LED indicator: -PS(N)-L

 240SOL

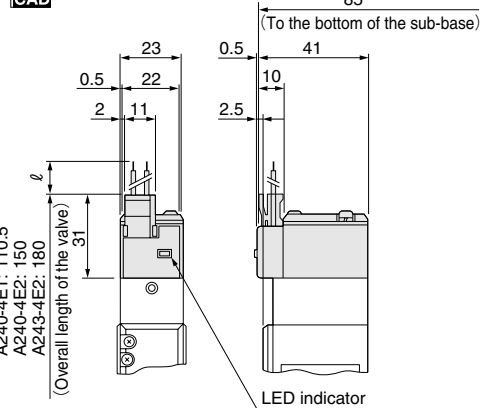

A240-4E1: 110.5
A240-4E2: 150
A243-4E2: 180
(Overall length of the valve)

●L connector with LED indicator: -PL(N)-L

 240SOL

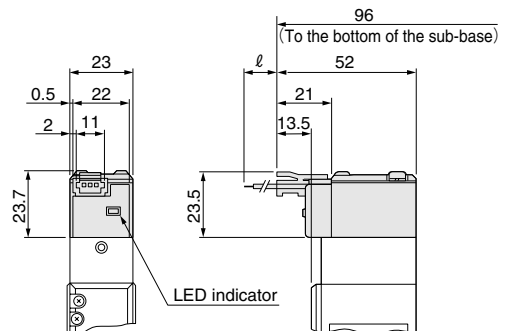

Dimensions of Manifold (mm)

●240M□F



SOLENOID VALVES 240 SERIES

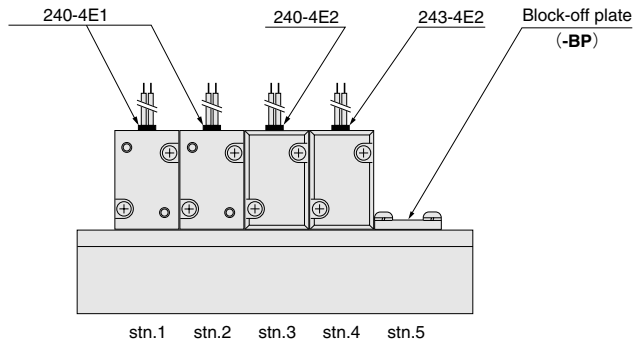
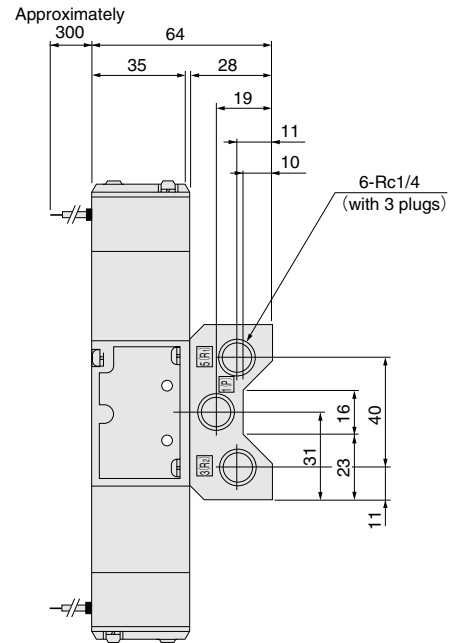
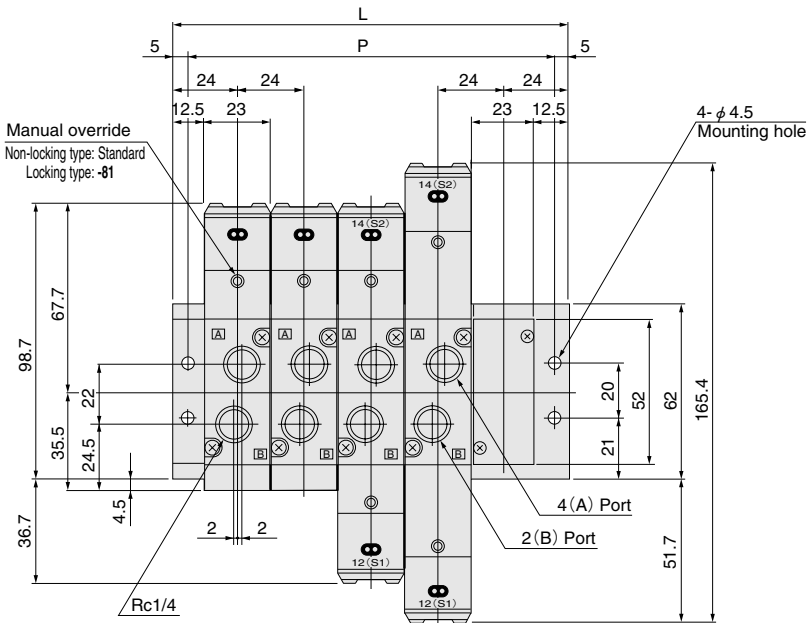

Unit dimensions

Model	L	P
240M2F	72	62
240M3F	96	86
240M4F	120	110
240M5F	144	134
240M6F	168	158
240M7F	192	182
240M8F	216	206
240M9F	240	230
240M10F	264	254

Options

● Straight connector with LED indicator: -PS(N)-L

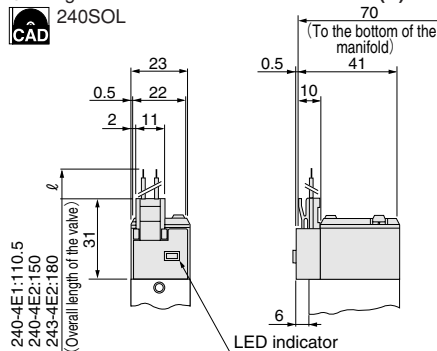

● L connector with LED indicator: -PL(N)-L

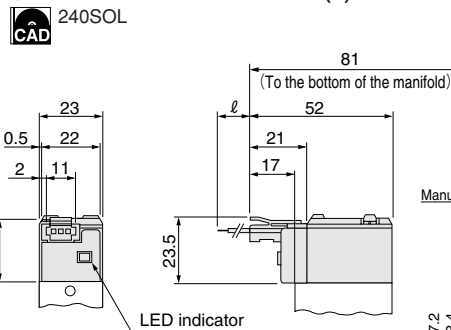

● Built-in varistor for surge suppression: -ZR
Dimensions are the same as the standard product.

● DIN connector : -39

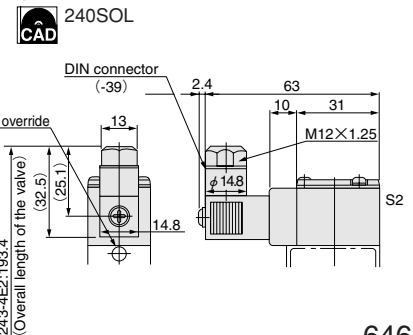

Dimensions of Manifold (mm)

●240M□A
●240M□B

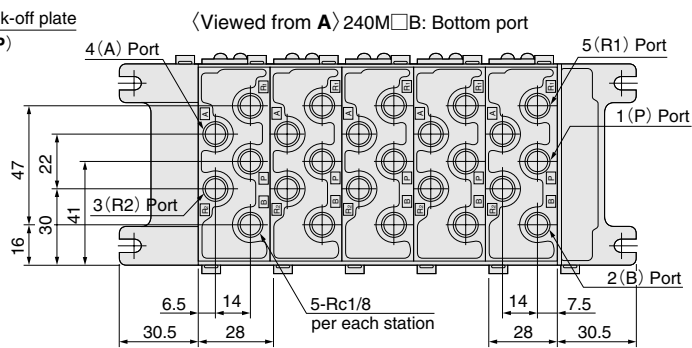
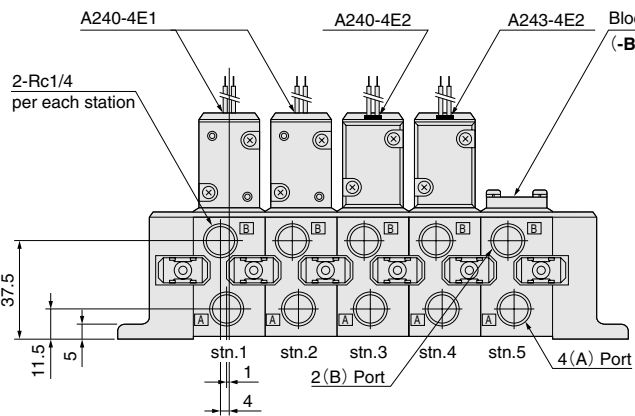
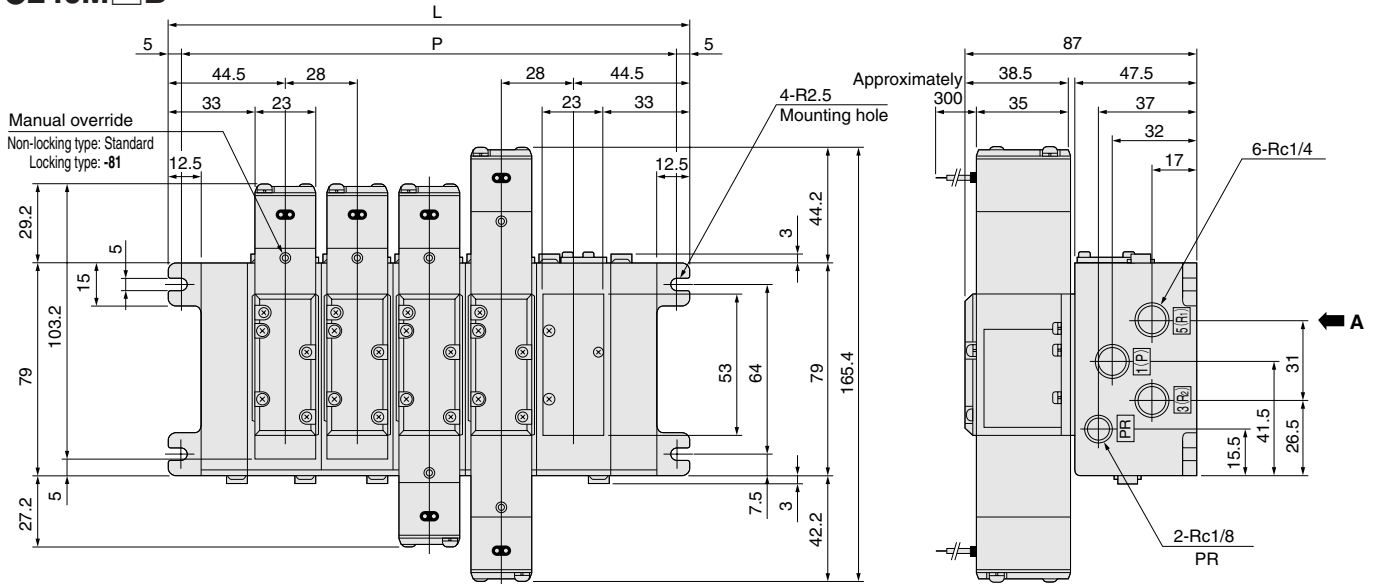

Unit dimensions

Model	L	P
240M2A, 240M2B	117	107
240M3A, 240M3B	145	135
240M4A, 240M4B	173	163
240M5A, 240M5B	201	191
240M6A, 240M6B	229	219
240M7A, 240M7B	257	247
240M8A, 240M8B	285	275
240M9A, 240M9B	313	303
240M10A, 240M10B	341	331

Options

●Straight connector with LED indicator: -PS(N)-L

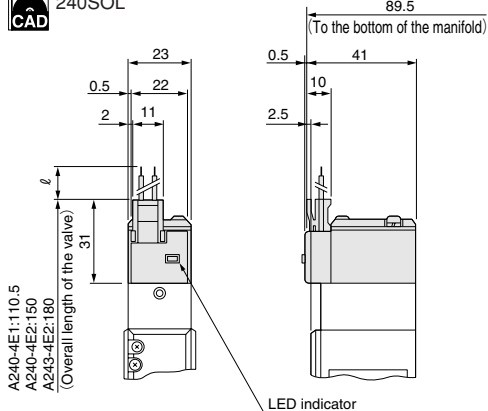

●L connector with LED indicator: -PL(N)-L

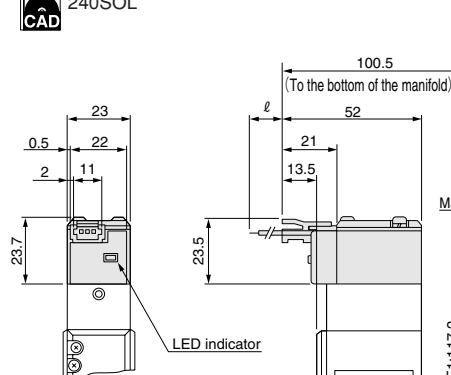

●With built-in varistor for surge suppression: -ZR
Dimensions are the same as the standard product.

●DIN connector: -39

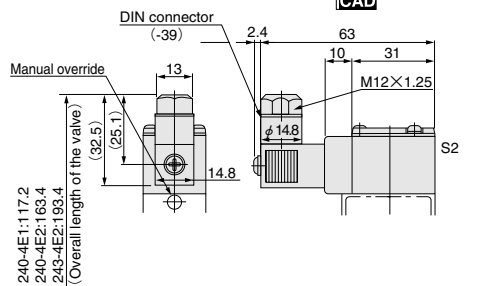
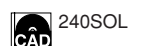

Dimensions of Manifold (mm)

- 240M □ AW
- 240M □ BW

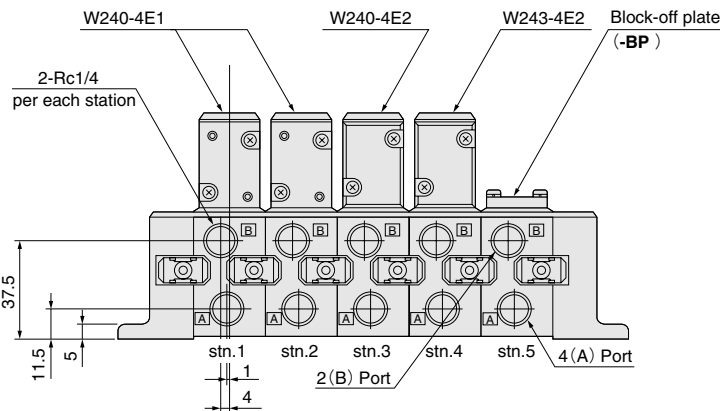
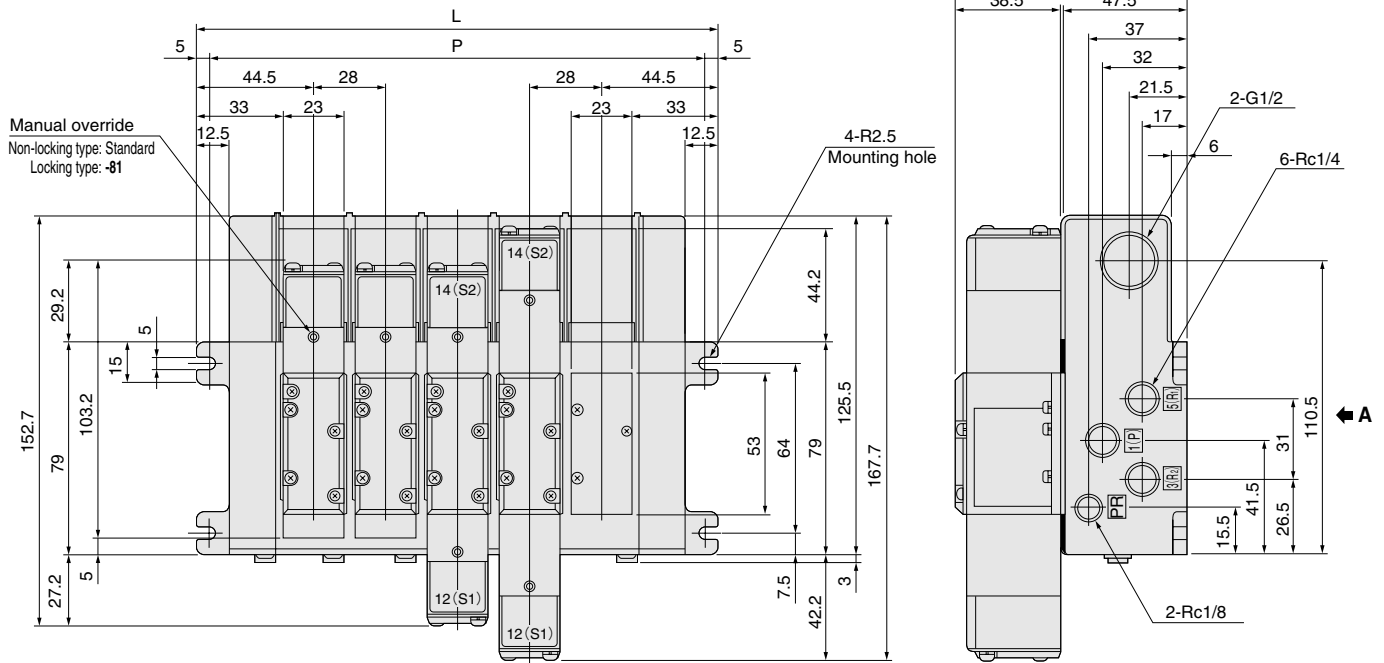

Unit dimensions

Model	L	P
240M 2 AW, 240M 2 BW	117	107
240M 3 AW, 240M 3 BW	145	135
240M 4 AW, 240M 4 BW	173	163
240M 5 AW, 240M 5 BW	201	191
240M 6 AW, 240M 6 BW	229	219
240M 7 AW, 240M 7 BW	257	247
240M 8 AW, 240M 8 BW	285	275
240M 9 AW, 240M 9 BW	313	303
240M10AW, 240M10BW	341	331

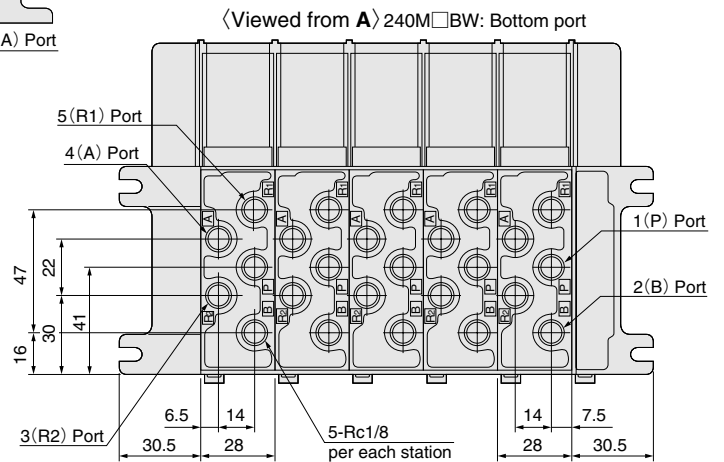

Options

- With LED indicator: -L

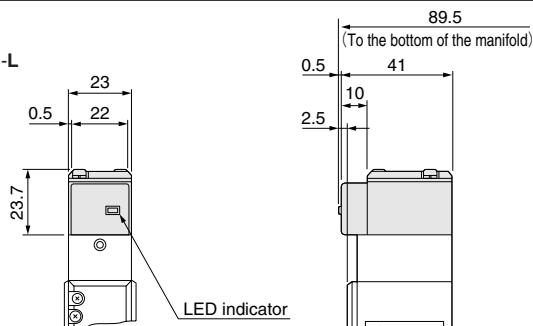

- Plug-in type with built-in varistor for surge suppression: -ZR
- Dimensions are the same as the standard product.

Made to Order

Air-piloted valves 240 series

● The optimum air valve for master valves or pilot valves for all-pneumatic control.

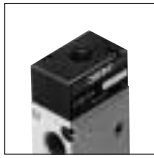

Specifications

Item	Basic model	For direct piping F type manifold		For sub-base For A type and B type manifolds	
		Single pilot	Double pilot	Single pilot	Double pilot
Media		Air			
Operation type		Air piloted type			
Number of positions, Number of ports		2 positions, 5 ports			
Effective area [Cv]	mm ²	16 [0.88]		11.3 [0.627]	
Port size	Main	1 (P), 4 (A), 2 (B) : Rc1/4		1 (P), 4 (A), 2 (B), 3 (R2), 5 (R1) : Rc1/4	
	Pilot	3 (R2), 5 (R1) : Rc1/8		Piston R: Rc1/8 ^{Note 1}	
Lubrication		Rc1/8			
		Not required			
Operating pressure range	Main	0.17~0.7 {1.7~7.1} [25~102]			
	Pilot	See the table "Minimum Pilot Pressure"			
Proof pressure	MPa [kgf/cm ²] [psi.]	1.05 {10.7} [152]			
Operating temperature range (atmosphere and media)	°C [°F]	5~60 [41~140]			
Shock resistance	m/s ² [G]	1373.0 [140.0]			
	Lateral direction				
	Axial direction	912.0 [93.0]	264.8 [27.0]	912.0 [93.0]	264.8 [27.0]
Mounting direction		Any			
Maximum operating frequency	Hz	5			
Mass	g [oz.]	110 [3.88]	135 [4.76]	110 [3.88] (300 [10.58]) ^{Note 2}	135 [4.76] (325 [11.46]) ^{Note 2}

Notes: 1. Port size of sub-base and manifold.

2. Figures in parentheses () are the mass with sub-base.

Remarks: For optional specifications and order codes, see p.637~638.

Minimum Pilot Pressure

Model	Main pressure	0.15 [1.5] [22] [※]	0.3 [3.1] [44]	0.5 [5.1] [73]	0.7 [7.1] [102]
240-4A		0.15 [1.5] [22]	0.22 [2.2] [32]	0.31 [3.2] [45]	0.4 [4.1] [58]
240-4A2		0.06 [0.6] [9]	0.07 [0.7] [10]	0.09 [0.9] [13]	0.1 [1.0] [15]

※: Reference value.

Time Required for Switching

Model	Operation	Pilot line length L m [ft.]					
		2 [6.6]	6 [19.7]	10 [32.8]	20 [65.6]	50 [164]	100 [328]
240-4A	ON	0.07	0.18	0.32	0.65	2.10	5.80
	OFF	0.15	0.42	0.72	1.50	4.32	12.20
240-4A2	ON	0.09	0.23	0.40	0.83	2.73	7.0
	OFF						

Measurement Conditions

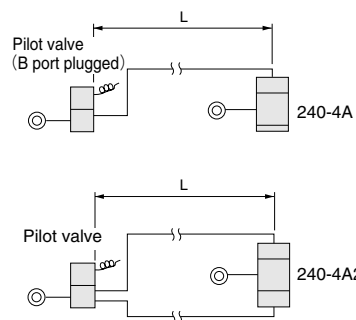

- Pilot valve=050-4E1 (effective area 1.2mm² [Cv: 0.07])
- Tube inner diameter =4mm [0.16in.]
- Air pressure (both main and pilot) =0.5MPa [73psi.]

Manifold Specifications and Port Size

Manifold model	Specifications	Port size	Applicable valve model	Remarks	
240M□F	1(P), 3(R2), 5(R1) ports manifold piping 4(A), 2(B) ports valve piping	1 (P)	Rc1/4	240-4A 240-4A2	
		4 (A), 2 (B)			
		3 (R2), 5 (R1)			
240M□A	All port manifold piping	1 (P)	Rc1/4	A240-4A A240-4A2	
		4 (A), 2 (B)			
		3 (R2), 5 (R1)			
240M□B	All port manifold piping Bottom ported	Piston R		A240-4A A240-4A2	
		End plate and side port	1 (P)		Rc1/4
			4 (A), 2 (B)		
			3 (R2), 5 (R1)		
		Bottom port	Piston R		Rc1/8
			1 (P)		Rc1/8
4 (A), 2 (B)					
3 (R2), 5 (R1)					

For order codes, see p.638.

Manifold Mass

g [oz.]

Manifold model	Mass of calculation for each unit (n=number of units)	Mounting valve				Block-off plate
		240-4A	240-4A2	A240-4A	A240-4A2	
240M□F	(68Xn)+69 [(2.40Xn)+2.43]	110 [3.88]	135 [4.76]	—	—	30 [1.06]
240M□A	(167Xn)+217 [(5.89Xn)+7.65]	—	—	110 [3.88]	135 [4.76]	30 [1.06]
240M□B	(167Xn)+217 [(5.89Xn)+7.65]	—	—	110 [3.88]	135 [4.76]	30 [1.06]

Calculation example: The mass of 240M10F stn.1~5 240-4A
stn.6~10 240-4A2, (68X10)+69+(110X5)+(135X5)=1974g [69.63oz.]

Cylinder Operating Speed and Flow Rate

240-4A

Measurement conditions

- Air pressure: 0.5MPa {5.1kgf/cm²} [73psi.]
- Piping inner diameter and length: $\phi 7.5 \times 1000\text{mm}$ [39in.]
- Fitting: Quick fitting TS10-02
- Load ratio = $\frac{\text{Load}}{\text{Cylinder theoretical thrust}} (\%)$
- Cylinder stroke: 300mm [11.8in.]

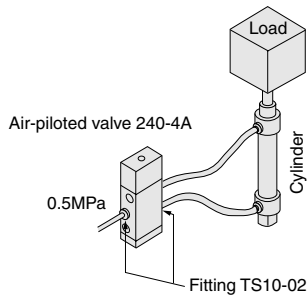

A240-4A-25

Measurement conditions

- Air pressure: 0.5MPa {5.1kgf/cm²} [73psi.]
- Piping inner diameter and length: $\phi 7.5 \times 1000\text{mm}$ [39in.]
- Fitting: Quick fitting TS10-02
- Load ratio = $\frac{\text{Load}}{\text{Cylinder theoretical thrust}} (\%)$
- Cylinder stroke: 300mm [11.8in.]

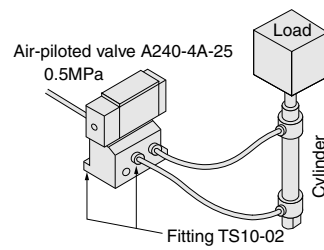

Maximum operating speed

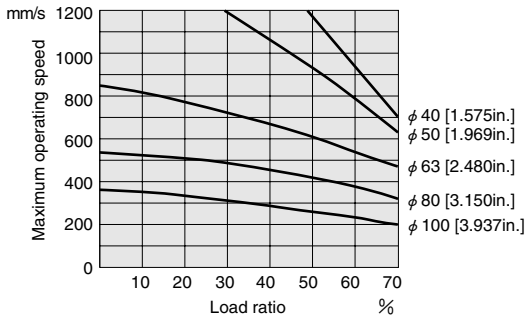

1mm/s=0.0394in./sec.

Maximum operating speed

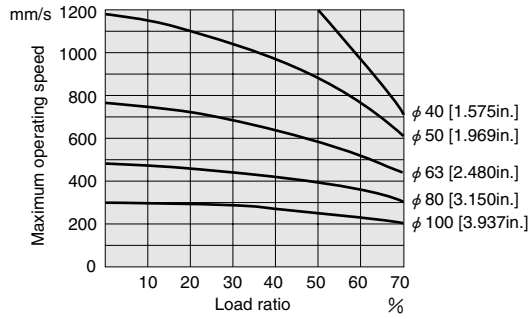

Flow rate

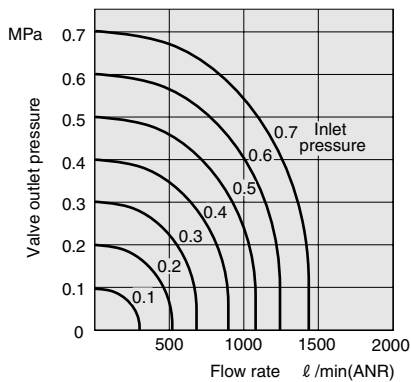

1MPa=145psi.
1 l/min.=0.0353ft³/min.

Flow rate

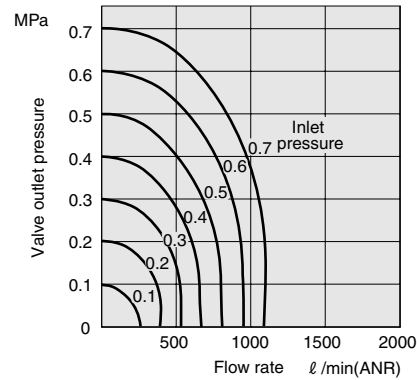

5-port, 2-position

Single pilot
240-4A

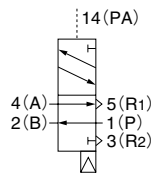

Double pilot
240-4A2

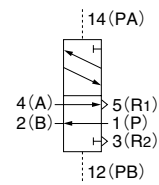

240-4A

240-4A2

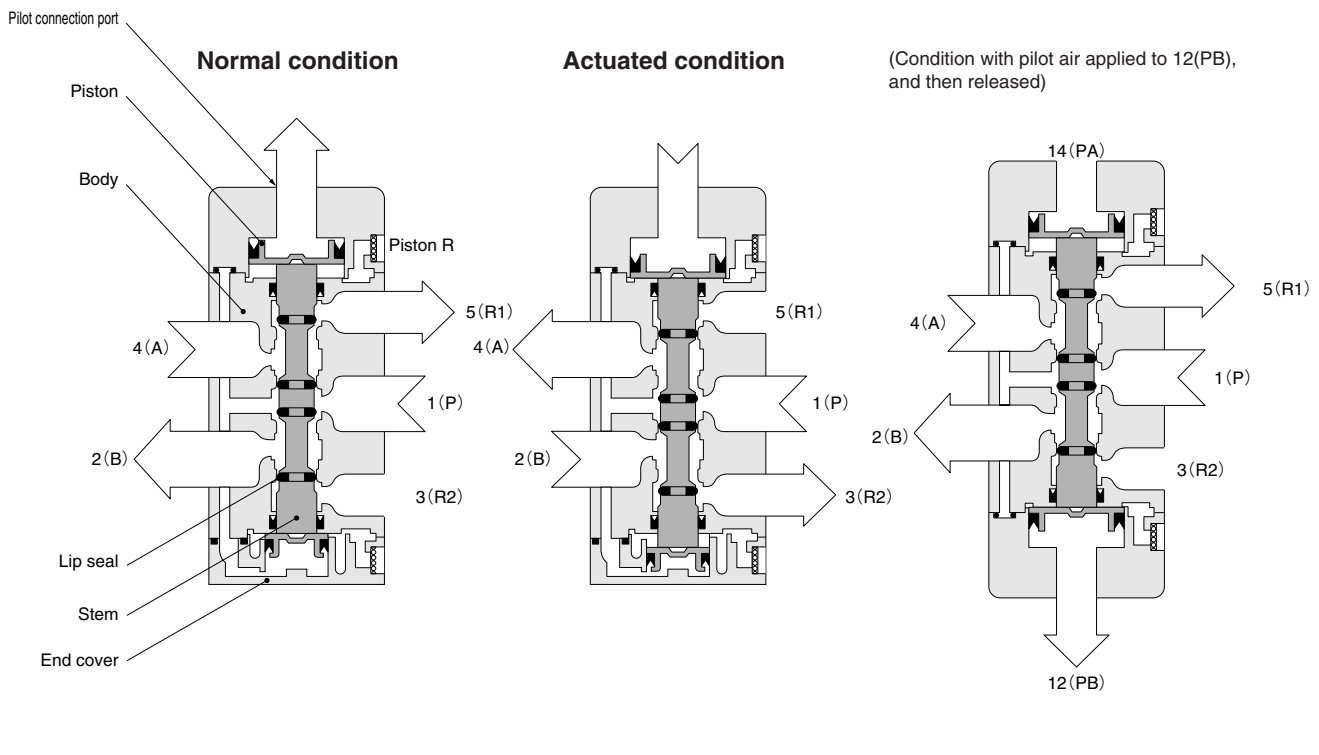

Major Parts and Materials

	Parts	Materials
Valve	Body	Aluminum alloy
	Stem	Aluminum alloy (anodized)
	Lip seal	Synthetic rubber
	Mounting base	Mild steel (zinc plated)
	Sub-base	Aluminum alloy (anodized)
Manifold	Body	Aluminum alloy (anodized)
	Block-off plate	Mild steel (zinc plated)
	Seal	Synthetic rubber

Dimensions of Air-piloted Valves (mm)

●240-4A

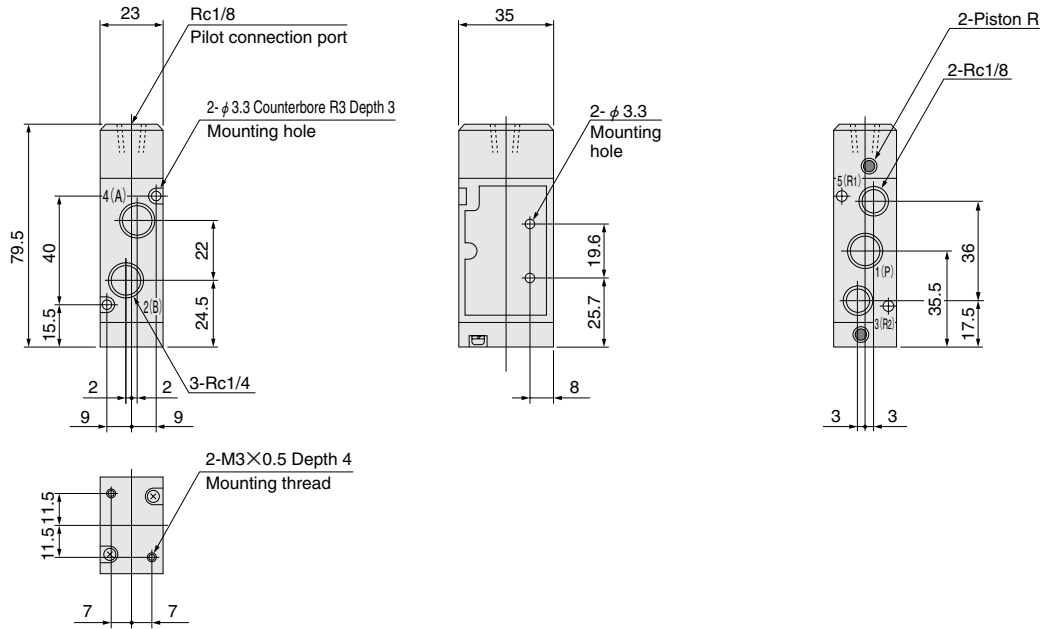

●240-4A2

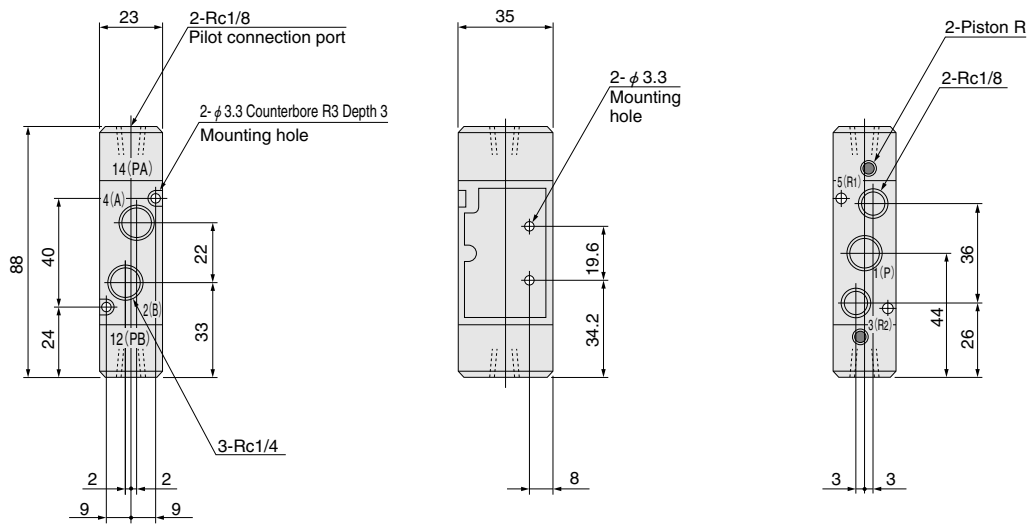

Options

●Mounting base: -21

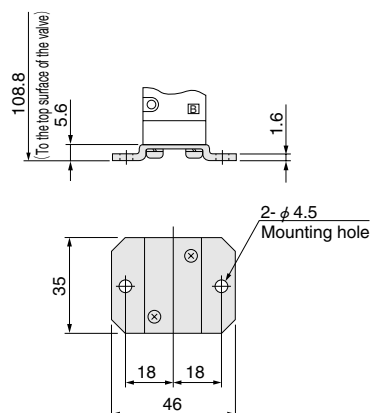

●Speed controller: -70

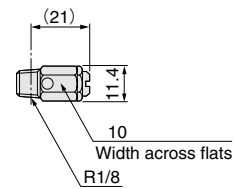

Dimensions of Air-piloted Valves (mm)

● A240-4A-25

● A240-4A-27

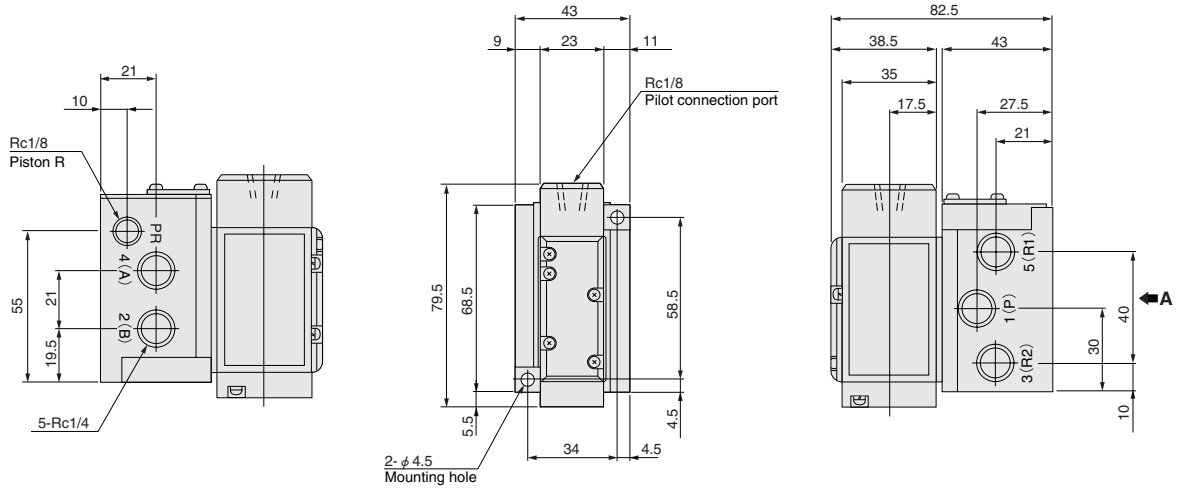

● A240-4A2-25

● A240-4A2-27

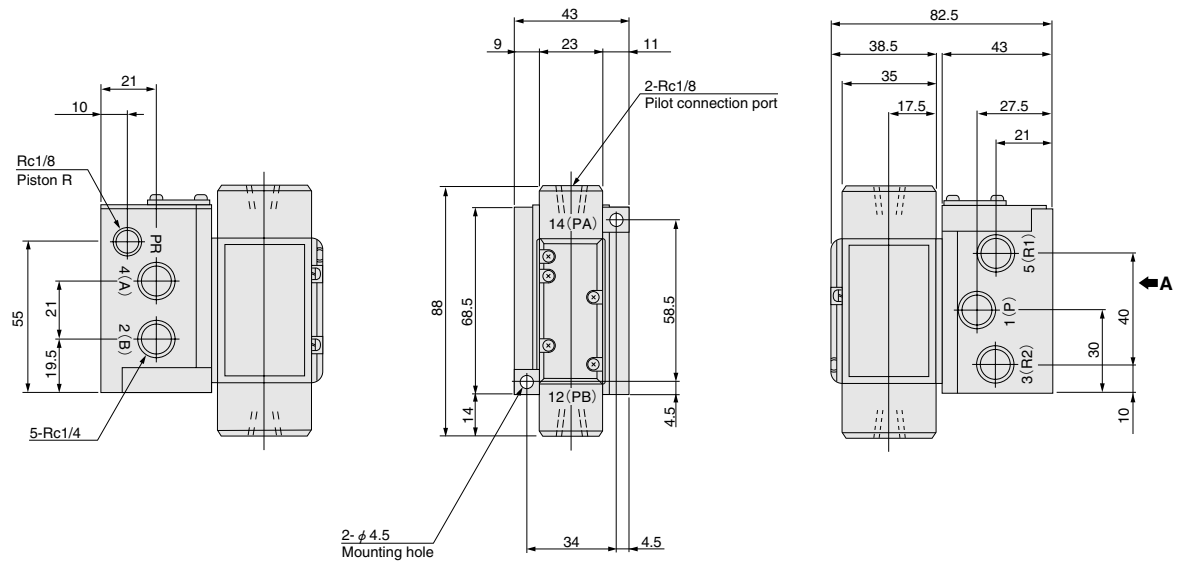

Options

- Speed controller: -70

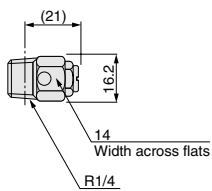

⟨Viewed from A⟩

-27: Bottom port

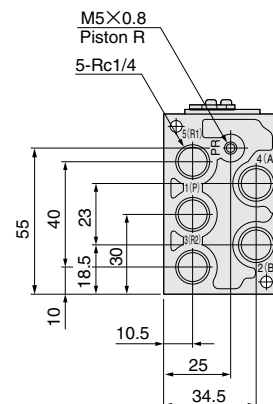

Handling Instructions and Precautions



Solenoid

Internal circuit

● AC100V, AC200V

Standard solenoid

Solenoid (Surge suppression)
Order code: -ZR

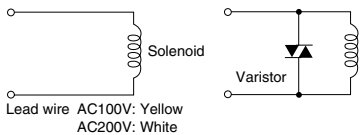

Solenoid with LED indicator (Surge suppression)

Order code: -PS-L
-PL-L

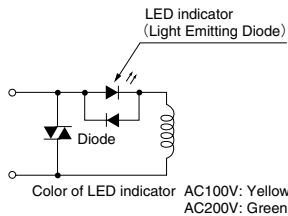

● DC24V

Standard solenoid (Surge suppression)

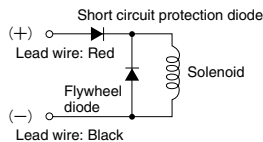

Solenoid with LED indicator (Surge suppression)

Order code: -PS-L
-PL-L

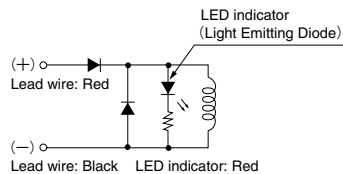

Plug connector

Attaching and removing plug connector

Use fingers to insert the connector into the pin, push it in until the lever claw latches onto the protruded section of the connector housing, and complete the connection. To remove the connector, squeeze the lever along with the connector, lift the lever claw up from the protruded section of the connector housing, and pull it out.

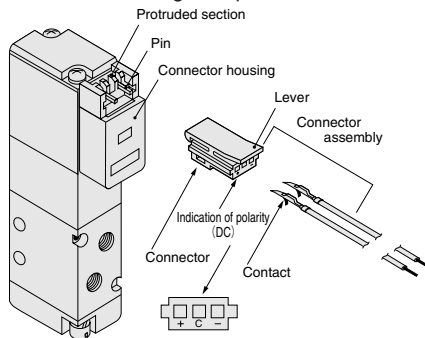

※ Illustration shows the 110 series.

Crimping of connecting lead wire and contact

To crimp lead wires into contacts, strip off 4mm [0.16in.] of the insulation from the tip of the lead wire, insert it into the contact, and crimp it. Be sure to avoid catching the insulation on the exposed wire crimping section.

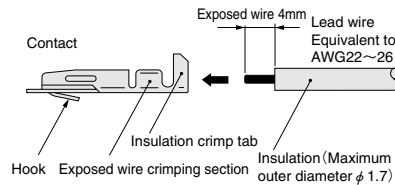

- Cautions:**
1. Do not pull hard on the lead wire.
 2. Always use a dedicated tool for crimping of connecting lead wire and contact.
Contact: Model 702062-2M
Manufactured by Sumiko Tech, Inc.
Crimping tool: Model F1-702062
Manufactured by Sumiko Tech, Inc.

Attaching and removing contact and connector

Insert the contact with lead wire into a plug connector □ hole until the contact hook latches on the connector and is secured to the plug connector. Confirm that the lead wire cannot be easily pulled out. To remove it, insert a tool with a fine tip (such as a small screwdriver) into the rectangular hole on the side of the plug connector to push up on the hook, and then pull out the lead wire.

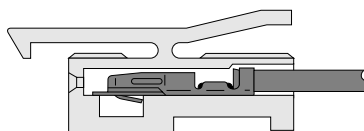

- Cautions:**
1. Do not pull hard on the lead wire. It could result in defective contacts, breaking wires, etc.
 2. If the pin is bent, use a small screwdriver, etc. to gently straighten out the pin, and then complete the connection to the plug connector.



Manual override

Non-locking type

To operate the manual override, press it all the way down. For single solenoid, the valve works the same as when in the energized state as long as the manual override is pushed down, and returns to the normal position upon release.

For the double solenoid, pressing the manual override on the 12(S1) side switches the 12(S1) to enter the energized position, and the unit remains in that state even after the manual override is released. To return it to the normal position, operate the manual override on the 14(S2) side. This is the same for the solenoids 14(S2).

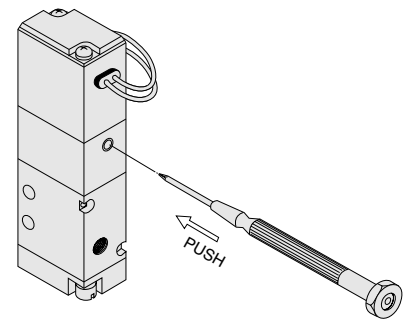

※ Illustration shows the 110 series.

Locking type

To lock the manual override, use a small screwdriver to push down on the manual override all the way down and turn it 45 degrees. Either turning direction at this time is acceptable.

When locked, turning the manual override from the locking position releases a spring on the manual override, returns it to its normal position, and releases the lock. When the manual override is not turned, this type acts just like the non-locking type.

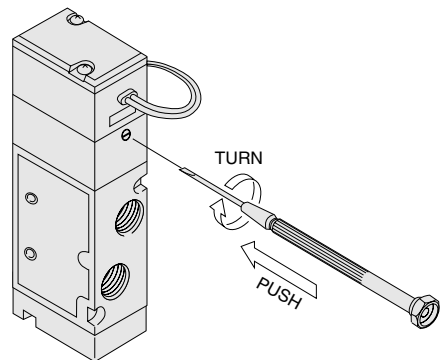

※ Illustration shows the 240 series.

- Cautions:**
1. The 240 series valves are pilot type solenoid valves. As a result, the manual override cannot switch the main valve without air supplied from the 1(P) port.
 2. Always release the lock of the locking type manual overrides before commencing normal operation.
 3. Do not attempt to operate the manual override with a pin or other object having an extremely fine tip. It could damage the manual override button.
 4. Do not turn the adjusting knob more than needed. It could result in defective operation.

Handling Instructions and Precautions



Manifold

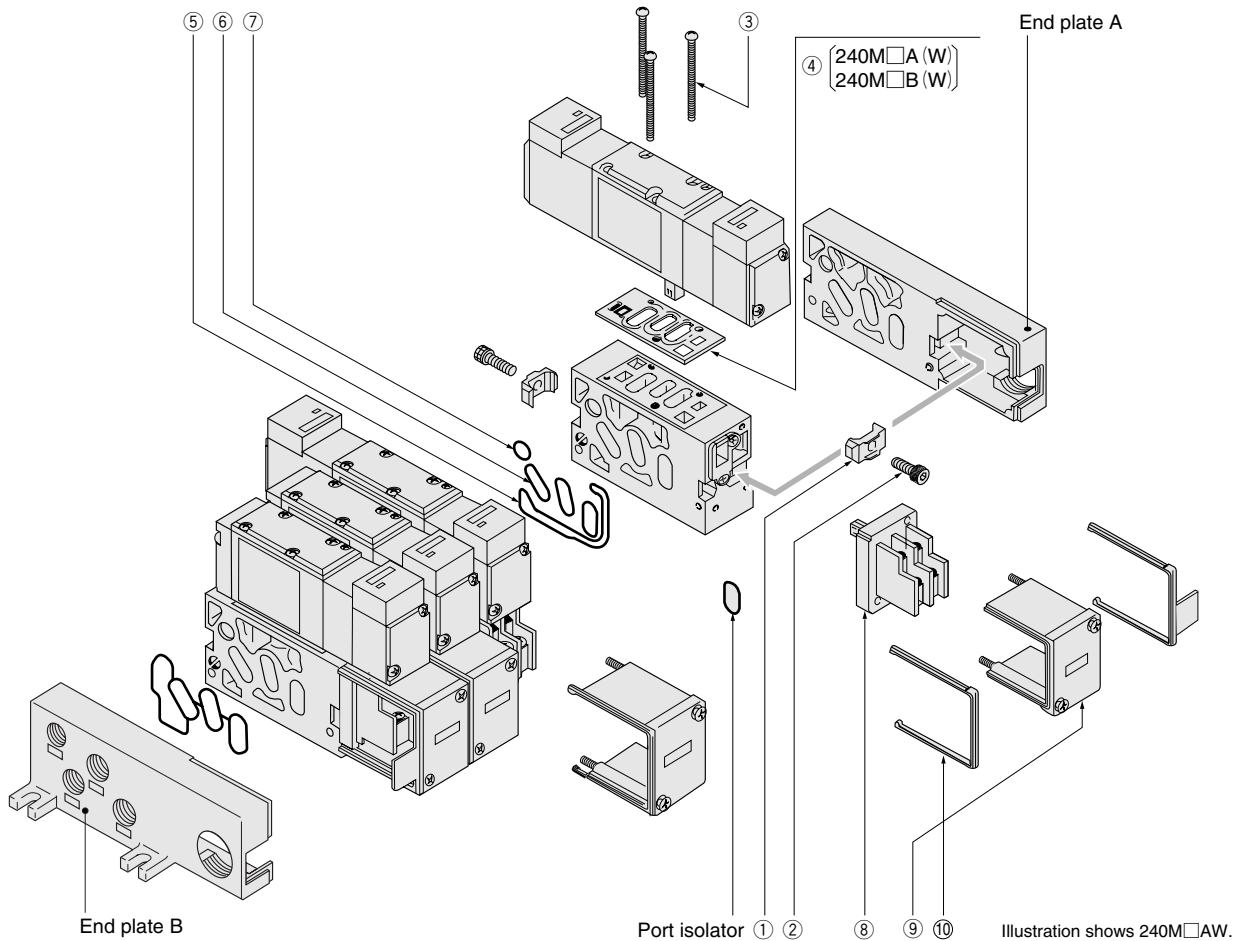

Piping

The 1(P) port, 3(R2) port, 5(R1) port and PR port are on both ends of the manifold, and piping direction can be selected depending on the mounting location. At shipping, the ports on one side are plugged. Remove the plugs and then use sealing tape or another sealing agent to tighten in place.

- Cautions:**
- For the 1(P) port piping, use a size that matches the manifold's piping connection port. Insufficient flow rate or pressure could result in defective valve operation or in insufficient actuator output.
 - When installing piping or mufflers to the 3(R2) and 5(R1) ports, ensure there will be minimum exhaust resistance. On rare occasions, exhaust from valves can interfere with other valves and actuators.
 - When a multiple number of valves operate simultaneously on a multi-unit manifold, or when the manifold with valves is used at high frequency, supply air from the 1(P) ports on both ends, and exhaust air from the 3(R2), 5(R1) ports on both ends.
 - In bottom ported manifolds (B type and BW type), use of the bottom 1(P), 3(R2) and 5(R1) ports can prevent flow rate or pressure shortages, or exhaust interference.

Stacking unit order

If stacking part is required due to the addition or replacement of manifold units, use the following order codes to place orders.

No.	Parts	Order codes	Parts lists (quantities)
—	Stacking unit for 240M□A	CR016	A type stacking unit (1): ① joints (2), ② joint mounting bolts (2), ③ valve mounting screws (3), ④ gasket (1), ⑤ gasket (1), ⑥ O-rings (3)
—	Stacking unit for 240M□B	CR017	B type stacking unit (1): ① joints (2), ② joint mounting bolts (2), ③ valve mounting screws (3), ④ gasket (1), ⑤ gasket (1), ⑥ O-rings (3), ⑦ O-ring (1), Rc1/8 plugs (5), Rc1/4 plugs (2)
—	Stacking unit for 240M□AW	CR018	AW type stacking unit (1): ① joints (2), ② joint mounting bolts (2), ③ valve mounting screws (3), ④ gasket (1), ⑤ gasket (1), ⑥ O-rings (3), ⑧ terminal block (1), ⑨ terminal cover (1), ⑩ connection cover (1)
—	Stacking unit for 240M□BW	CR019	BW type stacking unit (1): ① joints (2), ② joint mounting bolts (2), ③ valve mounting screws (3), ④ gasket (1), ⑤ gasket (1), ⑥ O-rings (3), ⑦ O-ring (1), ⑧ terminal block (1), ⑨ terminal cover (1), ⑩ connection cover (1), Rc1/8 plugs (5), Rc1/4 plugs (2)
⑧	Terminal block	CR020	

Stacking

The A Type, B Type, AW Type and BW Type manifolds are the stacking type, for flexible addition or reduction of units.

● Assembly instructions

240M□A and 240M□B

Loosening the joint mounting bolts (hexagon socket head bolts) ② on both ends and removing the joint ① lets the stations be separated.

To add units, position the O-rings ⑥ and ⑦ and gasket ⑤ in the stacking unit stations, install the joint, and tighten the joint mounting bolts.

240M□AW and 240M□BW

Loosen the set screw on the terminal cover, remove the terminal cover ⑨ and connection cover ⑩, and pull out the terminal block ⑧.

Loosening the joint mounting bolts on both sides and removing the joint lets the stations be separated. To add units, first position O-rings and gaskets in the stations to be added, install the joint, and tighten the joint mounting bolts. Then, fit the terminal block, secure the terminal cover in place with mounting screws, and fit the connection cover.

Bottom port

Since the B Type and BW Type manifolds have piping ports on the bottom of the manifold, both the bottom and side ports can be used as required.

● Piping port location

With the 1(P) port on both ends and the bottom surface, the 4(A) and 2(B) ports on the side and bottom surfaces, and the 3(R2) and 5(R1) ports on both ends and the bottom surface, piping is allowed in any location. Use the plugs provided with the manifold, with sealing tape or another sealing agent, to block off the unused ports.

Port isolator

Port isolators on the 1(P), 3(R2) and 5(R1) ports can be used to separate them from adjacent stations, to allow supply of different pressures, or to prevent exhaust interference.

Port isolators can be fitted and assembled between stations in place of the O-rings ⑥ to separate the 1(P), 3(R2) and 5(R1) ports from adjacent stations. For stations split by port isolators, plumb the 1(P), 3(R2) and 5(R1) ports on the bottom.

Block-off plate

To close up the unused stations, use a block-off plate (order code: **-BP**).

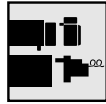

Plug-in

Mounting and removing valves

With the plug-in type, valves can be replaced while leaving the air piping or electrical wiring in place.

Loosen the 3 valve mounting screws, and pull the valve straight out. To mount the valve, align the valve plug over the socket of the sub-base or manifold, and fit it straight in. Then tighten the valve mounting screws to secure it in place.

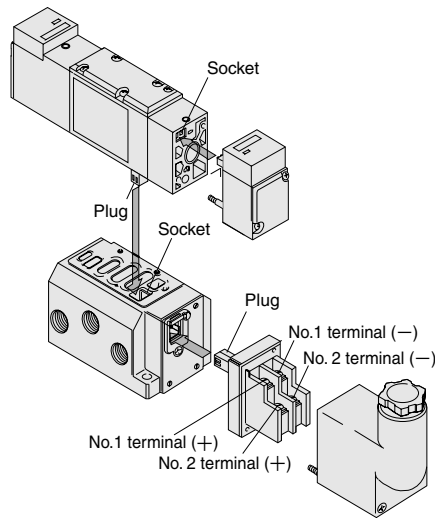

Wiring instructions

In the plug-in type, the terminal block and solenoid are connected by a plug and socket. Loosen the terminal cover mounting screws, remove the terminal cover, and then pull out the terminal block and connect it. Fit the connected terminal block into the sub-base or manifold, mount the terminal cover, then secure the mounting screws in place.

Connect the single solenoid leads to the No. 2 (+, -) terminal.

In the double solenoid, the No.1 (+, -) terminals are connected to the valve's solenoid 12 (S1), and the No.2 (+, -) terminals to the solenoid 14 (S2). For DC models, pay attention to the polarity. While a wrong in polarity will not cause a short circuit, the valve will not operate.

For the terminal, use the round terminal JIS2805 R type 1.25-3 or equivalent.

To order the terminal block and other parts for adding units, see the manifold parts order item on p.657. A collective common type manifold that uses crossover contacts can also be manufactured. Consult us.

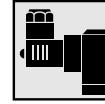

DIN connector

Wiring instructions

● Solenoid with DIN connector

When de-sheathing (outer sheath of the cable only), pay attention to the outlet direction of the lead wire. The cover will be easy to mount when the lead wire on the outer side of the terminal cover interior is set to about 8mm [0.31in.] longer than the inner side. Without stripping off the sheath, insert the lead wire until it contacts the lead wire stopper on the terminal body, and then place the contact from the upper side. Then use pliers to press the lead wire further to ensure that the contacts are firmly holding the core wire.

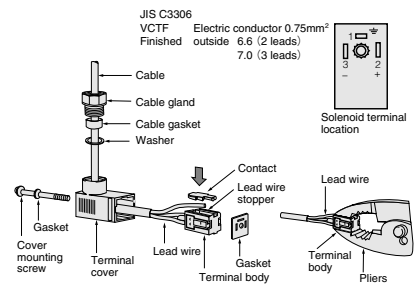

Note: The appropriate tightening torque for the cover mounting screw is 29.4N·cm {3kgf·cm} [2.6in·lbf].